

Hydra 2000

This manual applies to systems containing version 9 software



USER MANUAL

Premier Way, Abbey Park
Romsey, Hampshire, SO51 9DH
England

Tel: (+44) 01794 518448
Fax: (+44) 01794 518077
www.BandG.com

© Brookes & Gatehouse Ltd. 2004
The copyright of this Manual is the property of Brookes & Gatehouse Ltd.

Hydra 2000

USER MANUAL

Amendment No. 05 February 2003

CONTENTS

Product Liability and Safety Warnings

Record of Amendments

PART 1 - INTRODUCTION

PART 2 - OPERATING INFORMATION

PART 3 - CALIBRATION

PART 4 - INSTALLATION INFORMATION

PART 5 - OPTIONS

PART 6 - DIAGNOSTIC DATA

APPENDIX 1 CALIBRATION DATA

PRODUCT LIABILITY AND SAFETY WARNINGS

PRODUCT LIABILITY

Brookes and Gatehouse Limited accept no responsibility for the use and/or operation of this equipment. It is the user's responsibility to ensure that under all circumstances the equipment is used for the purposes for which it has been designed.

WARNING - ELECTRICAL HAZARD

This equipment uses high voltage electrical power. Contact with high voltages may result in injury and/or loss of life.

WARNING - CALIBRATION

The safe operation of this equipment is dependent on accurate and correct calibration. Incorrect calibration of this equipment may lead to false and inaccurate navigational readings placing the yacht into danger.

WARNING - NAVIGATION HAZARD

The Hydra 2000 is an Electronic Navigation System and is designed to assist in the navigation of your yacht. It is not designed to totally replace conventional navigation procedures and precautions and all necessary precautions should be taken to ensure that the yacht is not placed into danger.

CAUTION

This equipment is designed for use with a power supply source of 12v dc. The application of any other power supply may result in permanent damage to the equipment.

The use of alcohol or solvent-based cleaners will damage this equipment and any warranty in force will be invalidated.

Displays installed into Steel or Carbon-Fibre locations should be insulated from the structure to prevent the damage to the casings as a result of the effects of electrolysis.

PART 1 - INTRODUCTION

CONTENTS

Para		Page
1.1	SYSTEM DESCRIPTION	1-3
1.2	PROCESSORS	1-3
1.2.1	Main Processor Unit	1-3
1.2.2	Expansion Unit	1-4
1.2.3	Halcyon Gyro Processor	1-4
1.3	SENSORS	1-4
1.3.1	Masthead Unit	1-4
1.3.2	Paddle Wheel	1-5
1.3.3	Sonic Speed Unit	1-5
1.3.4	Depth Sensor	1-5
1.3.5	Super Halcyon 3 Fluxgate Compass	1-5
1.3.6	Halcyon 2000 Compass	1-5
1.3.7	Halcyon Gyro Stabilised Compass	1-5
1.3.8	Additional Sensors	1-6
1.4	DISPLAYS	1-6
1.4.1	NMEA Full Function Display (FFD)	1-6
1.4.2	Standard FFD	1-7
1.4.3	20/20 Display	1-7
1.4.4	40/40 Display	1-7
1.4.5	Analogue Indicators	1-7
1.4.6	Halcyon Display	1-7
1.5	CALIBRATION	1-8
1.6	DAMPING	1-8
1.7	MENU STRUCTURE	1-8

TABLES

Table No		Page
1.1	Function Menu Choices	1-9
1.2	Operational Menu Choices	1-11

PART 1 - INTRODUCTION

1.1 SYSTEM DESCRIPTION

The Hydra 2000 is a fully integrated instrumentation system that displays information obtained from various sensors on a choice of displays positioned throughout the yacht. Information is fed from the sensors to a Main Processor. From the information gathered by the sensors the Main Processor distributes information to the various displays via the Fastnet cable. This allows it to carry out a wide range of functions including dead reckoning, true wind speed and true wind direction, etc. These functions are controlled from a Full Function Display (FFD).

1.2 PROCESSORS

1.2.1 Main Processor Unit

The Main Processor is the heart of the system and can be connected to sensors that measure the following:

- Boat Speed/Log
- Depth
- Sea Temperature
- Air Temperature
- Compass Heading
- Measured Wind Speed
- Measured Wind Angle
- Ship's Supply Voltage
- Heel Angle
- Trim Angle
- Mast Rotation
- Barometric Pressure
- Forestay Load

From this information the Main Processor Unit is then able to calculate the following additional functions:

- Average Boat Speed
- Velocity Made Good (VMG) upwind/downwind
- Resettable Log
- Dead Reckoned Course and Distance
- Leeway
- Heading Corrected for Leeway (Course)

True Wind Speed
True Wind Angle
True Wind Direction
Heading on Next Tack or Gybe
Pressure Trend

In addition, the processor provides four outputs for analogue indicators. Any one of eight different types of analogue indicator can be used on any one of these outputs.

It also contains the battery-backed memory that stores all the calibration, damping and alarm settings whilst the power is OFF. These are adjustable from any FFD.

1.2.2 Expansion Unit

The Expansion Processor allows a further four analogue indicators and a number of additional sensors to be added to the system. Further details are given in Part 5 - Options.

1.2.3 Halcyon Gyro Processor

The Halcyon Gyro Processor is an interface between the Halcyon Gyro Stabilised Compass and the B&G Fastnet Network. It also outputs NMEA heading information at a rate of 10Hz for use with other marine instruments and AD10 for use with Radar.

The Halcyon Gyro Processor accepts NMEA data from your position fixer for magnetic variation information to allow display and output of True referenced heading.

The Halcyon Gyro Processor can also be used as an interface to either output NMEA heading and AD10 from a B&G system compass, or to accept True heading NMEA information from a gyro compass to output and display on a B&G system, along with AD10 and NMEA outputs.

Full details are given in Part 3 – Calibration.

1.3 SENSORS

1.3.1 Masthead Unit

The Masthead Unit senses apparent wind speed and wind angle. The unit is light weight and sealed.

1.3.2 Paddle Wheel

The Paddle Wheel Speed Sensor is designed primarily for cruising yachts and consists of a paddle wheel that protrudes through the hull via a housing. So that the paddle wheel may be cleaned at regular intervals the housing is provided with a flap valve that closes automatically when the unit is pulled back into the yacht.

1.3.3 Ultrasonic Speed Sensor

The Ultrasonic Speed Sensor provides highly accurate and stable boat speed measurement. The Ultrasonic Speed Sensor has no moving parts and requires minimal maintenance. The transducer can be fitted flush with the hull, creating zero drag, and can be painted, or anti-fouled over. The Ultrasonic Speed Sensor processes the sensor signals for use by the Hercules Main Processor, which then generates the boat speed and log functions.

1.3.4 Sonic Speed Unit

The Sonic Speed Unit provides highly accurate and stable boat speed measurement. It does not rely on mechanical moving parts that require constant attention to protect them from weed, etc. The transducers are fitted virtually flush with the hull, creating almost zero drag, and can be painted, faired or anti-fouled.

1.3.5 Depth Sensor

This can either be a removable through-hull unit, or moulded in-hull for reduced drag. The depth datum can be set to the waterline, the bottom of the keel or from the transducer.

1.3.6 Halcyon 2000 Compass

The Halcyon 2000 Compass is a high performance electronic fluxgate compass for use on both sailing and power craft. It is intended to be connected to Hercules 2000, Hydra 2000 or HS 2000 instrument systems through the B&G Fastnet Network.

The Halcyon 2000 Compass has the ability to 'learn' the magnetic effect of the vessel on the compass and automatically apply deviation correction.

1.3.7 Halcyon Gyro Stabilised Compass

The Halcyon Gyro Stabilised Compass (HGSC) is a high performance, solid state compass that provides the best available heading information through the use of rate gyros to correct for the motion of your yacht. It also provides high accuracy Heel and Trim. It interfaces to Hercules, Hydra and HS 2000 instruments via the Halcyon Gyro Processor that transmits this information to the B&G Fastnet Network.

The HGSC is an easily calibrated compass that 'learns' the magnetic effects of your vessel on the compass and automatically applies the deviation correction.

1.3.8 Additional Sensors

Additional sensors provide either single inputs, or improve the accuracy of other functions on the system and they are discussed in Part 5 - Options.

1.4 DISPLAYS

1.4.1 NMEA Full Function Display (FFD)

This is the standard system display and every Hydra 2000 must contain one NMEA FFD. The Standard FFDs and the other display types, described in this Section, are options with which the system can be expanded and made even more powerful.

The FFD's name gives an indication to the fact that they are really much more than just a display. It is a terminal for the whole system, allowing you to control everything from the functions displayed on them (and at the 20/20's) to the calibration of the system.

The FFD simultaneously displays two functions. Any system function can be called up on any FFD and can be placed on the system, all with full control of the Hydra 2000.

The NMEA FFD contains a NMEA interface which allows your Hydra 2000 System to be connected to devices such as position fixers, autopilots, chart plotters and radars, etc. from different manufacturers. For example your GPS Plus may be at the chart table, but you require its information to steer by on deck. Your Hydra displays can show that information if interfaced to your GPS Plus. The Hydra System can also provide information to your autopilot.

NMEA is the National Marine Electronics Association, who have produced a number of standard specifications for the interconnection of marine electronic instruments. These standards specify the electrical signals and the format of the data to be transferred.

Part 2 - Operating Information describes in detail the use of the FFD keyboard to control the Hydra 2000.

Part 4 - Installation Information shows NMEA in/out specifications.

1.4.2 Standard FFD

The Standard FFD is functionally identical and similar in appearance to the NMEA FFD. The only difference is that the Standard FFD is not fitted with a NMEA interface.

1.4.3 20/20 Display

The Hydra 2000 20/20 is a lightweight, large digit, liquid crystal display - it can be configured from any FFD or a remote button to display any system function.

The 20/20's operation is fully explained in Part 5 - Options.

1.4.4 40/40 Display

The Hercules 2000 40/40 is a lightweight, large digit, liquid crystal display which can be configured from any FFD or a remote button to display any system function.

The 40/40's operation is described in Part 5 - Options.

1.4.5 Analogue Indicators

There is a wide range of analogue indicators available. Refer to Part 5 - Options for full details.

1.4.6 Halcyon Display

This is a dedicated compass display that shows heading in digital form and has a bar graph display that can be used as a steering indicator.

Refer to Part 5 - Options for further details.

1.5 CALIBRATION

Before using the Hydra 2000 for navigational purposes it is important that the system is correctly calibrated for your installation. The calibration process has been simplified as much as possible, so that all you need is accurate information. This is fully explained in Part 3 - Calibration.

1.6 DAMPING

Another important facility that you need to be constantly aware of is the damping available on certain functions. This allows you to filter signal noise on the function when in unstable or rough conditions. The damping works by applying a filter over a time period; the more you increase this time period, the smoother the data readings will be, but the longer it will take to see the effect of any change. Similarly the lower the time period the greater the jumps you will see in the numbers, but the response to any change will be faster.

Damping should not be confused with the update rate which is the number of times each second that the function value is sent to the display. It is fixed for all the functions.

1.7 MENU STRUCTURE

The central concept to the operation of the system is the structure of the Function Menus accessed through the FFD, and once this is grasped, operation very quickly becomes familiar.

The idea of structured layers of menus is one seen everywhere in modern software, and regular computer users will be familiar with this concept.

The principle is that at any one level there is a set of choices which you can scroll through (select) until you find the one you want. Having found the correct menu entry, it is then selected - the FFD then displays the first choice in the next level of menu down. Here you once again scroll through the available options until you find and select your choice.

The function options available through each Menu Choice are listed in Table 1.1 - Function Menus. Operational Menu choices together with the Function Menu applicable are listed in Table 1.2 - Operational Menu Choices.

Note

The Functions available to the user are dependent on the range of sensors fitted to the system.

Details of the sensors required for each function are fully explained in Part 3 - Operating Information.

Table 1.1 - Function Menu Choices

FUNCTION	MENU CHOICE	FUNCTION TEXT
Speed	Boat Speed Average Speed Velocity Made Good	BOAT SPD AVG SPD VMG
Log	Stored Log Trip Log	STD LOG TRIP LOG
Depth	Depth - Meters Depth - Feet Depth - Fathoms	DEPTH M DEPTH FT DEPTH FM
Navigate	Heading Off Course Dead Reckoning Course Dead Reckoning Distance Course Leeway Tidal Set Tidal Drift	HEADING OFF CRSE D/R CRSE D/R DIST COURSE LEEWAY TIDE SET TIDE RTE
Wind	Measured Wind Speed (Kt) True Wind Speed Measured Wind Angle True Wind Angle True Wind Direction Head/Lift Trend Measured Wind Speed m/s True Wind Speed m/s	MEAS W/S TRUE W/S MEAS W/A TRUE W/A TRUE DIR LIFT/HDR MEAS W/S MS TRUE W/S MS
Perform	Opposite Tack Layline Heel Angle Fore/Aft Trim Mast Angle Wind Angle to the Mast Target True Wind Angle Trim Heel	OPP TACK LAYLINE HEEL TRIM MAST ANG W/A MAST TARG TWA TRIM HEEL

Table 1.1 - Function Menu Choices (Contd.)

Waypoint	Bearing W/point to W/point Mag. Bearing W/point to W/point True Bearing to W/point Rhumb Mag. Bearing to W/point Rhumb True Brg to W/point Great Circle Mag. Brg to W/point Great Circle True Distance to Waypoint Rhumb Distance to Waypoint Great Circle Course over Ground Mag. Course over Ground True SPD over Ground VMG to Waypoint Estimated Time of Arrival to WPT Cross Track Error	BRG W-W M BRG W-W T BTW RMB M BTW RMB T BTW GC M BTW GC T DTW RMB DTW GC CRSE O/G M CRSE O/G T SPD O/G VMG WPT ETA WPT CROSS TR
Motor	Battery Voltage	VOLTS
Temperature	Sea Temperature °C Sea Temperature °F Air temperature °C Air Temperature °F	SEA TEMP °C SEA TEMP °F AIR TEMP °C AIR TEMP °F
Timer	Timer Rolling 5 Timer	TIMER MS ROLLING 5 MS
Miscellaneous	Linear 1 Linear 2 Linear 3 Linear 4 Barometric Pressure Barometric Pressure Trend Rudder Angle	LINEAR 1 LINEAR 2 LINEAR 3 LINEAR 4 BAROMETER PR TREND RUDDER
Loadcell	Loadcells	LOADCELL
Tanks	Tank Sensors	TANKS
External	Remote 0 to 9	REMOTE 0 TO 9

Table 1.2 - Operational Menu Choices

OPERATION	AVAILABLE FUNCTION(S)	OPERATIONAL CHOICE
Log Control	Trip Log D/R Course D/R Distance	RESET RUN FREEZE

Table 1.2 - Operational Menu Choices (cont.)

OPERATION	AVAILABLE FUNCTION(S)	OPERATIONAL CHOICE
Timer Control	Timer	START STOP SYNC
PR Trend Control	PR Trend	PERIOD RESET
Alarm Control	BOAT SPD APP W/S DEPTH VOLTS SEA TEMP AIR TEMP	ALL OFF HI ALARM HI ON HI OFF LO ALARM LO ON LO OFF
Sector Alarm Control	HEADING APP W/A	ALL OFF SECTOR SECT ON SECT OFF
Damping Control	BOAT SPD APP W/A APP W/S HEADING TRUE W/A TRUE W/S HEEL TRIM TIDE RUDDER ANGLE	DAMPING VALUE
Dynamic Damping	BOAT SPD APP W/A APP W/S HEADING TRUE W/A TRUE W/S	DAMPING VALUE
Calibrate Log (AUTO CAL)	BOAT SPD STD LOG	SINGLE PORT CAL STBD CAL CAL DIST STRT RUN STOP RUN END CAL

Table 1.2 - Operational Menu Choices (cont.)

OPERATION	AVAILABLE FUNCTION(S)	OPERATIONAL CHOICE
Calibrate Log (MANL CAL)	BOAT SPD STD LOG	SINGLE PORT CAL STDB CAL
Calibrate Log (Ref Cal)	Boat SPD	Reference CAL
Calibrate Temp	Sea Temp °C Sea Temp °F	OFFSET C
Calibrate Datum	DEPTH	DATUM (+/-)
Calibrate Measured W/A	MEAS W/A	MHU ANGL
Calibrate Measured W/S	MEAS W/S	MHU CAL MHU OFFS
Calibrate Wind	TRUE W/A TRUE W/S	CORRECTN
All Other Calibrate Functions	Selected Function	CAL VALUE 1 CAL VALUE 2 CAL VALUE 3 CAL VALUE 4

PART 2 - OPERATING INFORMATION

CONTENTS

Para		Page
2.1	FULL FUNCTION DISPLAY (FFD)	2-5
2.1.1	The Keys	2-5
2.1.2	Power/Lights Key	2-6
2.1.3	Page Key	2-6
2.1.4	Scroll Keys	2-7
2.1.5	Enter/Reset Key	2-7
2.1.6	Speed/Depth (SPD/DEP) Key	2-8
2.1.7	Wind (WIND) Key	2-8
2.1.8	Navigation (NAV) Key	2-8
2.1.9	Remote Button Operation	2-9
2.2	Keylock	2-9
2.3	20/20 DISPLAY	2-10
2.4	HALCYON 2000 COMPASS	2-9
2.5	HALCYON DISPLAY	2-9
2.6	EXAMPLES OF OPERATION	2-10
2.6.1	Function Selection	2-10
2.6.2	Page Display Configuration	2-11
2.6.3	NAV Key Configuration	2-12
2.6.4	Damping Adjustment - Boat Speed	2-12
2.7	EXAMPLES OF CALIBRATION	2-13
2.7.1	Calibration Adjustment - Boat Speed	2-13
2.7.2	Calibration Adjustment - Depth	2-14
2.7.3	Calibration Adjustment - Wind Angle	2-14
2.8	ALARMS	2-15
2.8.1	Alarm Control	2-15
2.8.2	Alarm Types	2-15
2.8.3	Set LO Alarm - Depth	2-16
2.8.4	Switch Alarms On/Off	2-17
2.8.5	Disable Alarms	2-17
2.8.6	Selective Alarm Display	2-17
2.9	TRIP FUNCTIONS	2-18

CONTENTS (Contd.)

Para		Page
2.9.1	Fast Reset	2-18
2.9.2	Reset Timer	2-19
2.9.3	Rolling 5 Timer	2-19
2.9.4	Timer Alarm Sounder	2-19
2.9.3	Reset Trip Log	2-20
2.10	LIGHTING CONTROL	2-20
2.10.1	Select Local Control	2-20
2.10.2	Select System Control	2-21
2.11	OPERATING NOTES	2-21
2.12	OPERATING FUNCTIONS	2-21
2.12.1	Air Temperature	2-22
2.12.2	Measured Wind Angle	2-22
2.12.3	Measured Wind Speed	2-22
2.12.4	Average Speed	2-23
2.12.5	Barometric Pressure	2-23
2.12.6	Barometric Pressure Trend	2-24
2.12.7	Battery Voltage	2-24
2.12.8	Bearing to Waypoint	2-25
2.12.9	Bearing Waypoint to Waypoint	2-25
2.12.10	Boat Speed	2-25
2.12.11	Course	2-26
2.12.12	Course Over Ground	2-26
2.12.13	Dead Reckoning	2-27
2.12.14	Depth	2-29
2.12.15	Distance to Waypoint	2-29
2.12.16	Fore/Aft Trim	2-30
2.12.17	Heading	2-30
2.12.18	Heading on Opposite Tack	2-31
2.12.19	Head Lift Trend	2-31
2.12.20	Heel Angle	2-31
2.12.21	Leeway	2-32
2.12.22	Layline Distance	2-32
2.12.23	Local Time of Day	2-32
2.12.24	Loadcell	2-33
2.12.25	Mast Angle	2-33
2.12.26	Measured Wind Angle	2-34
2.12.27	Measured Wind Speed	2-34

CONTENTS (Contd.)

Para		Page
2.12.28	Next Waypoint Distance	2-34
2.12.29	Off Course	2-35
2.12.30	Rudder Angle	2-35
2.12.31	Sea Temperature	2-35
2.12.32	Speed Over Ground	2-36
2.12.33	Stored Log	2-36
2.12.34	Tidal Rate and Drift	2-37
2.12.35	Timer	2-38
2.12.36	Time to Layline	2-38
2.12.37	Time to Waypoint	2-38
2.12.38	Trip Log	2-39
2.12.39	True Wind Angle	2-39
2.12.40	True Wind Direction	2-40
2.12.41	True Wind Speed	2-41
2.12.42	Velocity Made Good (VMG)	2-41
2.12.43	Wind Angle to the Mast	2-42

ILLUSTRATIONS

Fig No		Page
2.1	Full Function Display	2-5
2.2	Sector Alarm	2-15
2.3	Dead Reckoning	2-28
2.4	Wind Angle	2-40
2.5	Calculation of VMG	2-42

Intentionally Left Blank

PART 2 - OPERATING INFORMATION

2.1 FULL FUNCTION DISPLAY (FFD)

The Hydra 2000 System is easily operated using the keys on any one of the NMEA or Standard Full Function Displays (FFD).

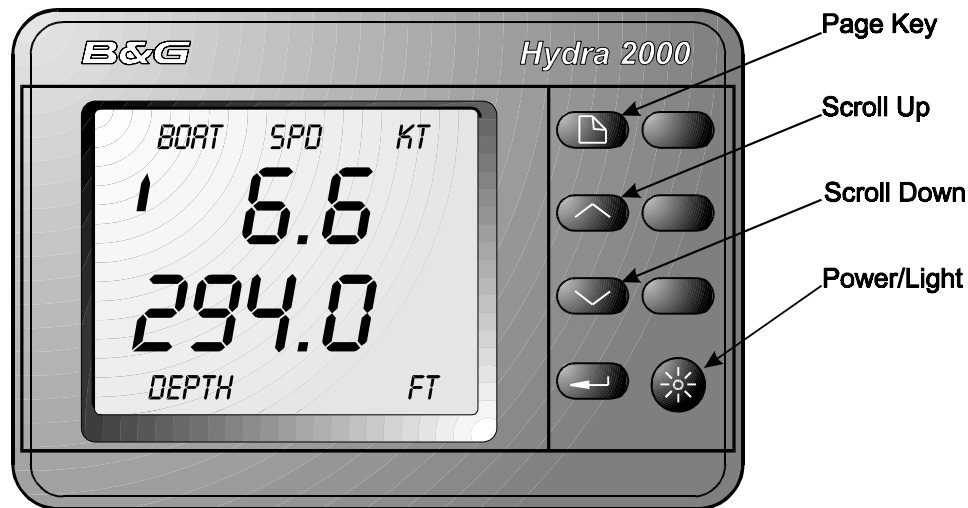

Fig 2.1 - Full Function Display

The information displayed on each FFD consists of a page of information comprising an upper display and a lower display. The FFD has four pages available that may be configured to display any function available in either the upper or lower displays. The user may also select any function for display at any time in either the upper or lower display.

In addition, three factory set pages relating to Wind, Speed/Depth and Navigate functions are incorporated into each FFD. These pages are accessed by pressing the related key on the FFD.

2.1.1 The Keys

All FFDs are provided with the following eight keys:

- Power/Lights Key
- Page Key
- Scroll Up Key
- Scroll Down Key
- Enter/Reset Key
- Speed/Depth Key
- Wind Key
- Navigation Key

2.1.2 Power/Lights Key

This key controls the application of power to the system and the level of illumination at all displays.

One short press of this key applies power to the Hydra System and the display is activated. A second short press of the key provides full background illumination on all system displays. Further short presses of the key decrease the illumination in three stages from full brightness to OFF.

The next press gives full illumination again. This operation on any one FFD within the system, performs the same sequence on all Hydra displays connected to the system. However, display lighting can be localised so that the level can be adjusted for individual displays (see Para 2.9 - LIGHTING CONTROL).

To switch OFF the system, press and hold down the key for three seconds. After this time lapses the message POWER-OFF appears in the upper text, release the key and after a further two seconds the system switches OFF and is now in Standby Mode.

2.1.3 Page Key

This key enables the user to select the User Defined Page (Display) presented on the FFD.

By pressing this key the user is able to choose any one of four user defined pages accessing various functions of the Hydra 2000 System (2 functions per page).

Notes

1. If you become lost in the system, press the **Page** Key and you will immediately return to the top level display without doing any damage.
2. Successive operations of the **Page** Key will bring up each of the user defined pages in rotation.
3. The four initial pages can be reconfigured to meet your specific needs, as described in Para 2.5.2
4. Holding down the **Page** Key for two seconds initiates control of 20/20 displays (see Part 5 - Options).

2.1.4 Scroll Keys

Two scroll keys are provided: **Scroll Up** and **Scroll Down**. The scroll keys have three functions:

1. Select the upper or lower display to change functions.
2. To scroll through (select) the menu choices.
3. To increase or decrease numerical values, such as calibration values.

Immediately after a specific page has been selected, pressing the **Scroll Up** Key will select the upper display. Similarly, operation of the **Scroll Down** Key will select the lower display.

2.1.5 Enter/Reset Key

The principle use of the **Enter** Key, is to make selections chosen from the menu by the scroll keys. As a general guide when any menu choice is flashing, pressing the **Enter** Key will select that choice. It is also used to:

Enter Data. When the value on the display needs changing it is altered by pressing the **Enter** Key. This starts the selected value flashing. Next using the **Scroll Up** or **Scroll Down** Keys, change it to the required value. Press the **Enter** Key again to complete the operation.

Accept and Reset Alarms. When an alarm sounds (if the audible warning is fitted) or flashes at the FFD, two presses of the **Enter** Key stops the warning and resets the alarm.

Expand Function Displays. When displaying the LOG and TIMER functions the **Enter** Key can be used to expand the display. Normally the Log function displays nautical miles to two decimal places, i.e. 99.99nm (maximum). One press of the **Enter** Key expands the display to 0099nm, giving a maximum available display of 9999nm if required. Similarly the TIMER function normally displays a minutes and seconds reading. Expansion by the **Enter** Key displays hours and minutes instead.

2.1.6 Speed/Depth (SPD/DEP) Key

By pressing the **SPD/DEP** Key the user is able to select any one of four factory set pages accessing the Speed and Depth functions. Successive operation of the **SPD/DEP** Key will display the following information in a fixed order:

- Boat Speed/Depth
- Boat Speed/Speed Over Ground (from NMEA Position Fix)
- Boat Speed/Apparent Wind Speed
- Boat Speed/True Wind Speed

2.1.7 Wind Key

By pressing the **Wind** Key the user is able to select any one of four factory set pages accessing the Wind Functions. Successive presses of the **Wind** Key will display the following information in a fixed order:

- Apparent Wind Speed/Apparent Wind Angle
- True Wind Speed/True Wind Direction
- True Wind Speed/True Wind Angle
- Apparent Wind Speed/True Wind Angle

2.1.8 Navigation (NAV) Key

By pressing the **NAV** Key the user is able to select any one of four factory set displays accessing the Navigation Functions. Successive presses of the **NAV** Key will display the following information in a fixed order:

- Current Heading/Course Over Ground
- Current Heading/Boat Speed
- Distance to Waypoint/Bearing to Waypoint
- Set tide/Tide Rate

Note

The NAV key may be configured to show waypoint information in either Great Circle or Rhumb line modes. Refer to section 2.5.3 for further details.

2.1.9 Remote Button Operation

Each FFD may be provided with an optional Remote Button to allow basic control of the associated FFD from a remote position. The Remote Button has two Functions: Page Selection and Fast Reset.

Page Selection is achieved by successive pressing of the Remote Push-Button. When the button is pressed each of the four user defined pages followed by the first page of the factory set Speed/Depth, Navigate and Wind pages are displayed in a fixed order.

When any one of the trip functions is selected at the associated FFD, pressing and holding down the Remote Push-Button for two seconds will change the display to show RESET flashing, or if TIMER is selected START 10 flashing. Pressing the Remote Button again will Reset that function, or in the case of TIMER start the countdown. After a reset the display will revert to normal page set-up automatically.

2.2 Keylock

To prevent accidental changing of the data displayed, or to any critical calibration values, two keylock features are available on the FFD's.

1. Press the **RESET** and **LIGHTS** keys simultaneously once. All keys except the **PAGE** key are locked.
2. Press the **RESET** and **LIGHTS** keys simultaneously once more. All keys are locked.

Press the **RESET** and **LIGHTS** keys simultaneously a third time. All keys are unlocked.

2.3 20/20 DISPLAY

The 20/20 is a fully programmable, single function display, incorporating large digits, which may be installed virtually anywhere in the yacht.

Control of the 20/20 Display may be achieved via any FFD or from an optional Remote Button, see Part 5 - Options.

2.4 HALCYON 2000 COMPASS

The Halcyon 2000 Compass is a high performance electronic transmitting compass which interface with your Hydra 2000 System. Heading and direction information may be selected for display on any of the FFDs or on a Halcyon Display. Additionally, analogue moving card compass displays may also be added.

Software incorporated within the compass allows the unit to learn the magnetic fields in the vessel that may cause deviation errors. These errors can be reduced to an insignificant level by following the Calibration procedure described in Part 3.

2.5 HALCYON DISPLAY

The Halcyon Display is a dedicated electronic compass display that may be connected to your Hydra 2000 System in the same manner as a regular FFD. It is a large digit display providing a clear and accurate digital indication of compass heading information together with a bar graph indicating port and starboard off-course error.

Control of the Halcyon Display and the associated functions can be achieved from the display, an optional Remote Push-Button or from any FFD, see Part 5 - Options.

2.6 EXAMPLES OF OPERATION

The general principle of operating the Hydra 2000 will be made clear by the following examples of Function, Page Selection and Damping.

2.6.1 Function Selection

Our first example will be to select another function for one of the pages. This new function is Stored Log that we want to place in the lower display.

- (1) Select the lower display by pressing the **Scroll Down** Key. The lower display will start to flash. The upper display is not affected.

- (2) Using the **Scroll Up** and/or **Scroll Down** Keys, scroll through the menu until the required menu (LOG) is shown

flashing in the lower display. The upper display is not affected.

(3) Press the **Enter** Key, the lower text now shows the STD LOG flashing, the upper display is not affected.

Note

If another menu choice is required (i.e. Trip Log) scroll through the menu choices using the **Scroll Up/Scroll Down** Keys until the required choice is displayed in the lower display.

(4) Press **Enter** again, the lower display now shows Stored Log function, the upper display is not affected.

At this stage we have simply called up this function to view it, if the **Page** Key is pressed then the configured page will return and Stored Log will no longer be on view. If however you wish to keep Stored Log on a page, then you can configure the page.

2.6.2 Page Display Configuration

The **Page** Key allows the user to configure four pages per FFD depending on its required use at that position.

To store the setting in Para 2.5.1 as a permanent new page, proceed as follows:

(1) Press **Scroll Up** or **Scroll Down** and scroll text until CNFG DSP is shown on Display.

Note

Scroll Up or **Scroll Down** can be used because we are configuring the whole page, both upper and lower displays.

(2) Press **Enter**, PAGE is shown on the lower display.

(3) Press **Enter**, the digital display is blanked and the two functions selected are displayed in the upper and lower displays.

(4) Press **Enter** to accept the new page configuration and restore the digital display.

All page displays are held in the display memory, independent of the power supply.

2.6.3 NAV Key Configuration

Our second example is configuring the NAV key. The NAV key allows the user to select either Rhumb Line or Great Circle navigation information to be displayed. To select the required mode, proceed as follows:

- (1) Press the **Page** Key once.
- (2) Press **Scroll Up** until the upper display shows CNFG DSP flashing.
- (3) Press **Enter**, the upper text now shows PAGE flashing.
- (4) Press **Scroll Up** to select either NAV MODE GC (Great Circle) or NAV MODE RH (Rhumb).
- (5) Press **Enter** to select your desired choice. The display will stop flashing.

2.6.4 Damping Adjustment - Boat Speed

Our third example is the entry of a damping value. To find out if it is possible to damp a function, refer to OPERATING Menu choices, Table 1.2.

- (1) Using the **Scroll Up** or **Scroll Down** Key select the upper or lower display as required.
- (2) If BOAT SPD is in the upper display press and hold **Scroll Down** and scroll to DAMPING which flashes. If BOAT SPD is in the lower display use **Scroll Up**.
- (3) Press **Enter** and the current damping value will be displayed on the upper or lower display as appropriate.
- (4) Press **Enter** and DAMPING value will start to flash.
- (5) Press **Scroll Up** or **Scroll Down** to increase and/or decrease the damping value as required.
- (6) Press **Enter** to accept new value.
- (7) Press **Page** to return to full display.

Damping control for any of the other functions that can be damped is achieved in a similar manner.

2.7 EXAMPLES OF CALIBRATION

The calibration method of your Hydra 2000 System will be made clear by the following examples. The Calibration Process is described in detail in Part 3 - Calibration.

2.7.1 Calibration Adjustment - Boat Speed

- (1) Using the **Scroll Up** or **Scroll Down** Keys select the upper or lower display as required.
- (2) If BOAT SPD (or STD LOG) is shown in the upper display, press and hold the **Scroll Down** Key to select CALIBRATE from the menu. If BOAT SPD (or STD LOG) is in the lower display use **Scroll Up**.
- (3) Press **Enter** and then press **Scroll Down** to select MANL CAL on the Display.
- (4) Press **Enter** and SINGLE is shown on the Display.

Notes

1. SINGLE is the choice required if a single paddlewheel or sonic sensor is fitted.
2. If two paddle-wheels or two sonic sensors are fitted, the **Scroll Up** or **Scroll Down** Keys should be used to select PORT CAL or STBD CAL as required.
 - (5) Press **Enter** to reveal the current calibration value in Hz/knot.
 - (6) To adjust the calibration value, press **Enter** and the value flashes.
 - (7) Using the **Scroll Up** and **Scroll Down** Keys to change the calibration value as required to the new calibration value.
 - (8) Press **Enter** to input the new calibration value into the system.
 - (9) Press **Page** to return to the normal display.

2.7.2 Calibration Adjustment - Depth

- (1) Using the **Scroll Up** or **Scroll Down** Keys select the upper or lower display as required.
- (2) If DEPTH is shown in the upper display, press and hold the **Scroll Down** Key to select CALBRATE from the menu. If DEPTH is in the lower display use **Scroll Up**.
- (3) Press **Enter** and the display shows DATUM which flashes.
- (4) Press **Enter** again, DATUM stops flashing and the current datum value is displayed.
- (5) Press **Enter** and the DATUM value flashes.
- (6) Use the **Scroll Up** or **Scroll Down** Keys to set the new DATUM value.

Note

If DATUM is referenced to the water line, the value is positive. If DATUM is referenced to the keel line, the value is negative and this is indicated by a minus sign before the left digit.

- (7) Press **Enter** to input the new DATUM value into the system.
- (8) Press **Page** to return to the normal display.

2.7.3 Calibration Adjustment - Wind Angle

- (1) Select APP W/A.
- (2) If APP W/A is on lower display press **Scroll Up** and scroll to CALBRATE which flashes. If APP W/A is on upper display, press **Scroll Down** and scroll to CALBRATE.
- (3) Press **Enter** twice and the current alignment value will be shown.
- (4) Press **Enter** and the current offset angle will flash. Use **Scroll Up** or **Scroll Down** to set the new value.
- (5) Press **Enter** to accept the new value.
- (6) Press **Page** to return to the normal display.

2.8 ALARMS

2.8.1 Alarm Control

When a pre-set alarm parameter is reached, e.g. the depth reducing, the system raises an alarm automatically. In an alarm condition, the lower display changes to highlight the cause of the alarm and flashes red and green alternatively until the **Enter** Key is pressed twice. At which point all the FFDs except the one on which **Enter** was pressed, return to normal. The audible alarm, if fitted, is also silenced by this operation. After this, the lower display continues to monitor the alarm condition. The alarm is still active and, if the alarm parameter is again exceeded, the alarm will flash/sound as necessary. The displayed alarm function remains on the lower display until **Page** is pressed.

2.8.2 Alarm Types

The system incorporates the following types of alarm:

HI ALARM - This is initiated if the value of a function exceeds a pre-set level.

LO ALARM - This is generated if the value of a function drops below a pre-set level.

SECTOR ALARM - This is generated when the value of a function leaves the safe sector as shown in Fig 2.2.

Example

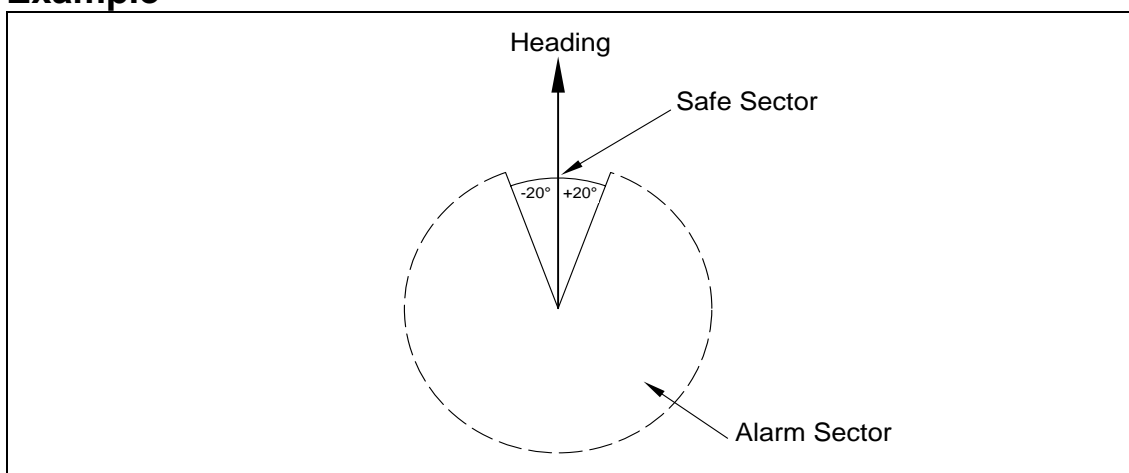

Fig 2.2 - Sector Alarm

For example, when the SECTOR alarm is turned on, the alarm reference heading is the current compass heading. If the SECTOR alarm is set at 40° the sector value is the compass heading +/- 20°. It is therefore important to switch OFF the SECTOR alarm before carrying out a course alteration and switching the alarm on again when settled on the new course heading.

Any alarm can be switched ON and OFF individually, or all alarms can be switched OFF collectively.

2.8.3 Set LO Alarm - Depth

- (1) Select function which requires alarm facility, e.g. DEPTH.
- (2) If the selected function is in the upper display, press **Scroll Down** and scroll the lower display until ALARMS appears, flashing. If the selected function is in the lower display use **Scroll Up**.
- (3) Press **Enter** and the text shows ALL OFF, flashing.
- (4) Using **Scroll Up** or **Scroll Down** as appropriate, scroll through until the text shows LO ALARM flashing.
- (5) Press **Enter** and the display shows the current LO ALARM value.
- (6) To change the LO value, press **Enter**, and the value flashes.
- (7) Press **Scroll Up** or **Scroll Down** to increase or decrease the value as required. Press **Enter** to accept the new value and switch the alarm ON.
- (8) Press **Page** to return to the normal display.

To select the HI alarm, scroll through the text until HI ALARM appears and press **Enter** to reveal current HI ALARM value. To change the value, use the same procedure as used to change the LO ALARM value.

2.8.4 Switch Alarms On/Off

To switch OFF an alarm (HI, LO or SECTOR), scroll through until the required item (e.g. HI OFF) appears in the text and press **Enter**.

To turn ON an alarm, press scroll through until the required item (e.g. LO ON) appears in the upper text and press **Enter**.

2.8.5 Disable Alarms

(1) Select any function with an alarm facility, e.g. DEPTH.

(2) If function is in the top display press **Scroll Down** to scroll to ALARMS, or if function is on the bottom use **Scroll Up** Key. Then press **Enter** and ALL OFF appears flashing.

(3) Press **Enter** again, all alarms are turned OFF and the normal page display will be restored.

2.8.6 Selective Alarm Display

When an alarm condition arises all FFD's in the system flash the alarm function on the bottom half of their displays.

Individual FFD's can be set to ignore alarm messages.

The procedure for Selective Alarm Display is as follows:

- (1) Press the **Page** key.
- (2) Scroll up to CNFG DSP, then press **Enter**.
- (3) Scroll up to SHOW ALM, then press **Enter**.
- (4) Scroll to NO, then press **Enter**.
- (5) Press the **Page** key to return to normal view.

This display is now set to ignore any alarm function.

WARNING - All alarms in the system will remain OFF until the values are reset or the individual alarms are switched ON again.

2.9 TRIP FUNCTIONS

The Hydra 2000 provides three trip functions - Timer (count up and count down), Trip Log and Dead Reckoning. The functions can be reset and restarted as required, e.g. for keeping a separate log of elapsed time and distance run for a given passage.

When any trip function is started, all other trip functions that have been reset start with it, except when the timer countdown is started. Under this condition, the other functions start again if previously reset, when the countdown reaches zero. This is designed for the start of races, so that you have DR, Resettable Log and Timer running, without pressing buttons during the moments of the start itself.

When a trip function is displayed, the two right-hand characters show the status of that function.

The letters MS (Minutes/Seconds) and NM (Nautical Miles) mean the function is running.

The letters RE stand for RESET, where the function is zeroed and waiting to be started.

The letters FR stand for FROZEN, where the displayed value is frozen, but the function is still counting in the background.

2.9.1 Fast Reset

The Hydra 2000 System incorporates a Fast Reset feature for all trip functions (Trip Log, Timer and Barometric Pressure Trend). Fast Reset can be initiated either by operation of a Remote Push-Button (see Para 2.1.9) or by operation of the **Enter** Key on any FFD.

Note

If two trip functions are displayed at the same time, the Fast Reset facility will only reset the function shown in the upper display.

2.9.2 Reset Timer

- (1) With **TIMER MS** shown on one half of the display, press the **Scroll** key adjacent to the opposite half of the display to display the **CONTROL** menu. Press **Enter** to activate the **SET/START/STOP/SYNC** loop function.
- (2) Scroll to **SET** and press **Enter**. The **SET** time flashes. Using the **UP/DOWN** arrow keys, alter the time (to a maximum of 120 minutes), press **Enter** to confirm the time selected. This automatically activates the **START** page.
- (3) When **START** is selected, the current **SET** time is transferred to the timer and it starts counting down.
- (4) The other half of the display shows **SYNC**. Pressing the **UP/DOWN** scroll arrow continues the cycle, pressing **Enter** will cause the timer value to be reset to the nearest whole minute.
- (5) When the timer reaches zero, the counter starts counting upwards. Selecting **START** in this condition resets the counter to the **SET** value and starts counting down again.

When **STOP** is selected, the timer stops at whatever value is currently displayed.

2.9.3 Rolling 5 Timer

As an alternative to the main settable timer, a 'rolling 5' is provided. This simply cycles from 5:00 minutes to zero then starts again counting down from 4:59, until stopped. The same **START**, **STOP** and **SYNC** functions as used in the settable timer are available in the **CONTROL** menu.

2.9.4 Timer Alarm Sounder

When the timer is counting down, the alarm sounder (fitted to the Hercules Main Processor) will sound every 10 minutes until the counter reaches 10 minutes to go, the alarm sounder will then sound briefly at the following intervals:

5:00, 4:00, 3:00, 2:00, 1:00, 0:30, 0:15, 0:10, 0:5. and 00:00.

2.9.5 Reset Trip Log

- (1) Display TRIP LOG in the upper display.
- (2) Press **Scroll Down** once and the lower text now shows CONTROL flashing.
- (3) Press **Enter** and use the **Scroll Down** key to display RESET flashing.
- (4) Press the **Enter** key and the display now shows RUN flashing.
- (5) Press the **Enter** key again and the display shows the trip log running.
- (6) Press the **Page** key to resume normal operation.

Note

Every time you reset the TRIP LOG the AVERAGE SPEED resets and begins its calculation again. The control facility for the Dead Reckoned functions work in the same way; the bearing and distance are linked, so that they are started simultaneously.

2.10 LIGHTING CONTROL

The level of illumination at system displays is controlled by the Power/Lights Key. Use of this key normally controls all the Hydra displays simultaneously. However, the level of illumination on a single FFD can be controlled individually using the menu choice - LIGHTING - LOCAL.

2.10.1 Select Local Control

- (1) Press and hold **Scroll Up** or **Scroll Down** until LIGHTING appears in the text.
- (2) Press **Enter**, **Scroll Down** until LOCAL appears in the text.
- (3) Press **Enter** again and the original page display appears. Control of the FFD Lighting is now in local mode.

Successive operation of the **Power/Lights** Key now controls the illumination level on that display only. This will enable you to use very low lighting at the chart table whilst keeping a higher intensity display up on deck.

2.10.2 Select System Control

- (1) Press and hold **Scroll Up** or **Scroll Down** until LIGHTING is displayed in the text.
- (2) Press **Enter** and **Scroll Up** or **Scroll Down** to select SYSTEM.
- (3) Press **Enter** again, the original page display appears and the illumination control has returned to System Control.

Note

In order to control the lighting on analogue repeaters, at least one FFD must be set to System Control.

2.11 OPERATING NOTES

Within the preceding paragraphs of this part of the manual the steps necessary to select a specific function and/or setup the system have been described in detail. The remainder of this manual contains some detailed examples; therefore to describe further operations the following shorthand system has been adopted.

Each successive selected menu choice will be in capitals, separated by a → symbol. For instance the example in Para 2.5.1, to manually calibrate the log, would be presented as follows:

SPEED → BOAT SPD, **CALBRATE** → **MANL CAL** → **SINGLE**

Menu choices in plain CAPITALS are the selection of the required function. Menu choices in **BOLD** are the selection of the relevant operation and are completed using the other half of the display.

2.12 OPERATING FUNCTIONS

The previous Paragraphs have described how the Hydra System is built up and how to use the keys and basic menu structure. The following Paragraphs describe each of the functions available in more detail and how these features can best be applied on the boat.

2.12.1 Air Temperature

Menu Heading:	TEMP
Function Text:	AIR TEMP
Update Rate:	1 Hz
Units:	Centigrade or Fahrenheit

Notes

1. Requires a Temperature Sensor.
2. Audible high/low alarm available.

2.12.2 Measured Wind Angle

Menu Heading:	WIND
Function Text:	APP W/A
Update Rate:	2 Hz
Units:	Degrees

Notes

1. Variable damping 0-99 seconds.
2. Analogue indicator available.
3. Audible sector alarm available

The apparent wind angle is the angle between the boat's bow and the wind blowing across deck. It is a basic number, useful in its own right like Boat Speed, Heading and Apparent Wind Speed and provides the starting point for the higher level, calculated functions.

A special analogue indicator, Magnified Wind Indicator, which only shows the 0-50 upwind/downwind sector of Apparent Wind Angle in a magnified form is available. This is described in Part 5 - Options.

2.12.3 Measured Wind Speed

Menu Heading:	WIND
Function Text:	APP W/S
Update Rate:	2 Hz
Units:	Knots or metres per second

Notes

1. Variable damping 0-99 seconds.
2. Audible, high/low alarm available.
3. Analogue indicator available.

The Measured Wind Speed is the speed of the wind blowing across the deck at mast height. A basic number from which the calculated functions are derived and important in its own right, as a lot of sail choices are judged by the Measured Wind Speed.

2.12.4 Average Speed

Menu Heading:	SPEED
Function Text:	AVG SPD
Update Rate:	1 Hz
Units:	Knots

Average speed is a trip function that averages your speed through the water over the period the trip log has been running, i.e.

Trip Log

Time it has been running

2.12.5 Barometric Pressure

Menu Heading:	MISC
Function Text:	BAROMETER
Update Rate:	1 Hz
Units:	Millibars

Notes

1. Requires pressure sensor.
2. Offset calibration available.

This is essential for the Offshore Sailor, giving not only the instantaneous barometric value but also the important trends towards higher or lower pressure. This helps position you in a weather system and so predict the next change.

After installation it is essential that the calibration (CAL VAL1) of the pressure sensor is checked against an accurate barometer and adjusted accordingly. To select CAL VAL1 for calibration proceed as follows:

MISC → BAROMETER, **CALBRATE → CAL VAL1**

2.12.6 Barometric Pressure Trend

Menu Heading:	MISC
Function Text:	PR TREND
Update Rate:	1 Hz
Units:	Millibars

This shows the change in pressure over a period of time that can be set for up to 24 hours. The period can be changed by selecting a control option in the OPERATION Menu using the following sequence:

MISC → PR TREND, **CONTROL** → **PERIOD**

A reset facility at the same menu level is also provided. This is selected using the following sequence:

MISC → PR TREND, **CONTROL** → **RESET**

This operation resets the data collected to zero.

2.12.7 Battery Voltage

Menu Heading:	MOTOR
Function Text:	VOLTS
Update Rate:	1 Hz
Units:	Volts

Notes

1. Audible, high/low alarm available.
2. Calibration.

This function measures the voltage that the batteries supply to the system. This is especially useful for monitoring the supply voltage offshore enabling you to optimise your engine running time.

To calibrate against another voltmeter, measure the voltage, then enter this actual voltage in using the following sequence:

MOTOR → VOLTS, **CALBRATE** → **CAL VAL1**

2.12.8 Bearing to Waypoint

Menu Heading:	WAYPOINT
Function Text:	BTW RMB or BTW GC
Update Rate:	Provided by position fixer
Units:	Degrees magnetic or true

Notes

1. Requires interfaced position fixing system.
2. Rhumb line, Great Circle, Magnetic or True.

Once the position fixer is connected and sending information, it automatically appears in the menu and becomes available for display.

2.12.9 Bearing Waypoint to Waypoint

Menu Heading:	WAYPOINT
Function Text:	BRG W-W
Update Rate:	Provided by position fixer
Units:	Degrees magnetic or true

Notes

1. Requires interfaced position fixing system.
2. This is the bearing from the active waypoint to the next waypoint in the active route.

2.12.10 Boat Speed

Menu Heading:	SPEED
Function Text:	BOAT SPD
Update Rate:	4 Hz
Units:	Knots, MPH or KPH

Notes

1. Port, starboard calibration with automatic facility.
2. Variable damping 0-99 seconds.
3. Acceleration, deceleration indicator.
4. Analogue indicators available.
5. Audible, high/low alarm available.

Boat speed is the most fundamental piece of information on the Hydra. It is used in many of the calculations of higher functions; e.g. true wind angle/speed/direction, VMG, the log and trip functions.

The accurate calibration of the paddlewheel or sonic speed sensor is essential. Hydra uses simple procedures for calibrating the speed sensors that are described in Part 4 - Calibration. On boats fitted with two sensors, connected by a gravity switch, Hydra will automatically use the calibration factor for the leeward sensor.

Boat speed is shown on the display with a small bar to the left of the digits that indicates the increase or decrease of speed. The amount of damping that is applied can be adjusted. This can be increased to smooth out the display value in rough conditions or conversely reduced to speed up the response in light conditions.

2.12.11 Course

Menu Heading:	NAVIGATE
Function Text:	COURSE
Update Rate:	1 Hz
Units:	Degrees magnetic or true

Note

Requires heel sensor.

This incorporates leeway (Course Made Good) into heading. Leeway can only be calculated if you have the heel sensor fitted. Course is the better function for most navigational purposes and should be used whenever possible.

2.12.12 Course Over Ground

Menu Heading:	WAYPOINT
Function Text:	CRSE O/G
Update Rate:	Provided by position fixer
Units:	Degrees magnetic or true

Note

Requires interfaced position fixer.

Once the position fixer is connected and sending information, it automatically appears in the menu and becomes available for display. This is your actual track over ground and is invaluable to the navigator for dealing with tidal areas.

2.12.13 Dead Reckoning

Menu Heading:	NAVIGATE
Function Text:	D/R CRSE or D/R DIST
Update Rate:	1 Hz
Units:	Degrees magnetic, nautical miles

Notes

1. Course and distance.
2. Corrected for leeway if heel sensor fitted.
3. Resettable as a trip function.

Formerly the mainstay of all offshore navigation, now with such widespread use of electronic position fixing equipment it is more often used as an essential back-up. It can be particularly effective as an indicator of the net course steered on long offshore legs. Both the course as a bearing from the start point, and its distance in nautical miles, can be displayed as separate functions. If the heel angle sensor is fitted then the course calculation will include leeway correction.

In the worst case, a Man Overboard (MOB) situation, immediately resetting the Dead Reckoning (DR) will bring the vessel back to the MOB position. DR is the course over the water and not over the land as would be given by a position fixer.

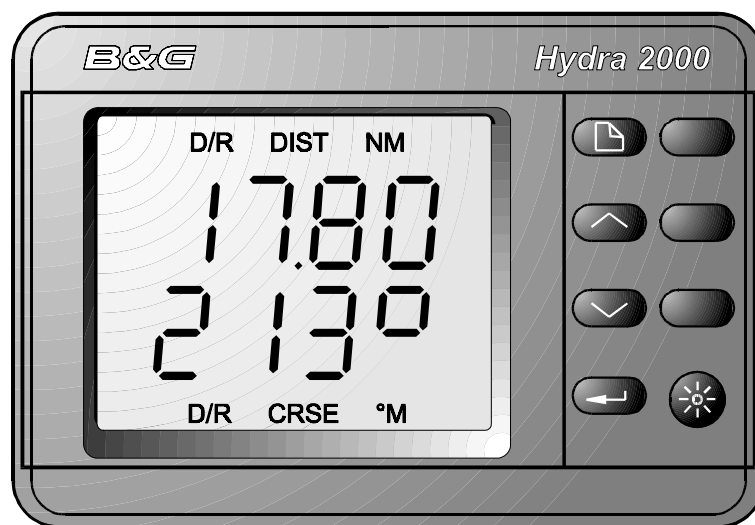
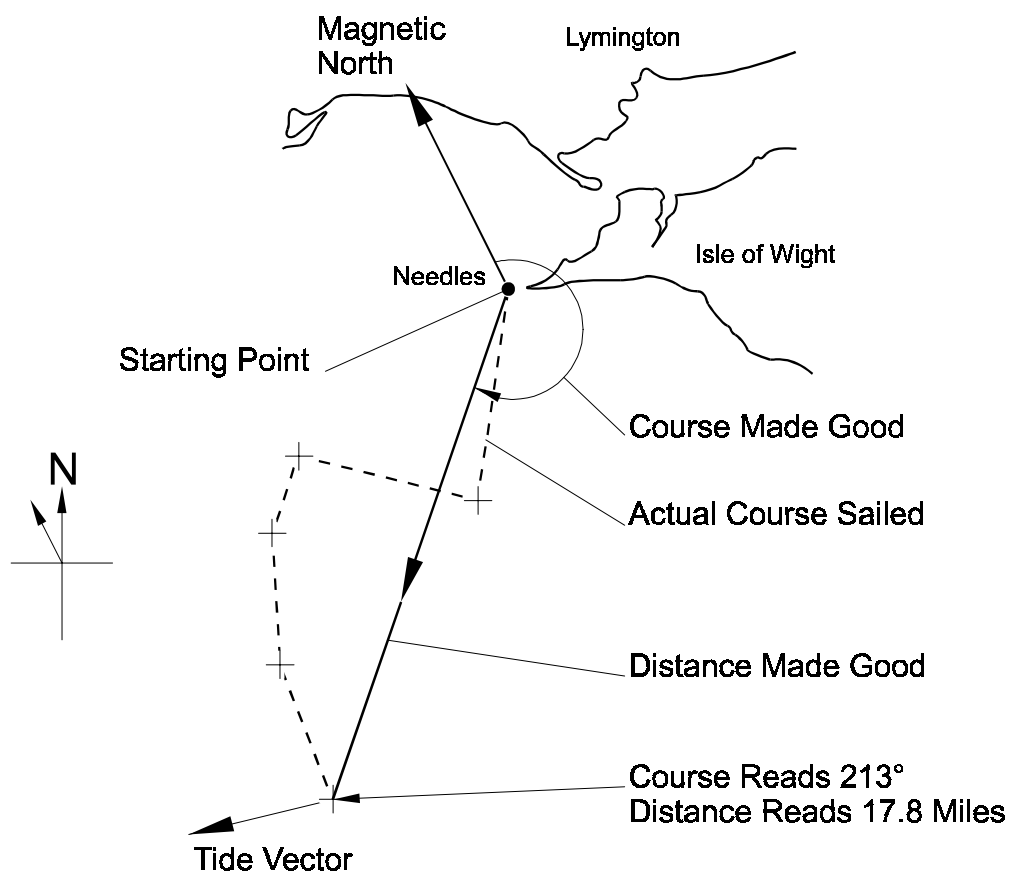

Fig. 2.3 - Dead Reckoning

2.12.14 Depth

Menu Heading:	DEPTH
Function Text:	DEPTH
Update Rate:	1 Hz
Units:	Metres, feet and fathoms

Notes

1. Audible, shallow/deep alarm available:
Shallow range 0-99.9m
Deep range unlimited
2. Analogue indicators available.

Depth is one of the most important functions on the boat, being an essential navigational and safety tool. A datum adjustment allows you to move the base point to give either depth under the keel or actual water depth (see Para 2.6.2).

Depth sounder performance is dependent on many factors: transducer type and installation, boat speed, electrical noise, sea state, sea bed conditions, air and plankton in the water. But however good the equipment, there will always be times when a reliable measurement of depth is not possible. In these cases, such as following in the wake of another boat, the display shows:



to indicate a signal problem.

The accuracy of the measurement is dependent on the velocity of sound and the amount the sound penetrates the sea bottom. Changes in the velocity of sound are not normally significant, however, errors up to one foot can result from sound penetration into very soft mud.

2.12.15 Distance to Waypoint

Menu Heading:	WAYPOINT
Function Text:	DTW RMB or DTW GC
Update Rate:	Provided by the position fixer
Units:	Nautical miles

Note

Rhumb Line or Great Circle.

Once the position fixer is connected and transmitting NMEA data, it automatically appears in the menu and is available for display.

2.12.16 Fore/Aft Trim

Menu Heading:	PERFORM
Function Text:	TRIM
Update Rate:	1 Hz
Units:	Degrees

Notes

1. Adjustable for horizontal sensor alignment.
2. Requires Halcyon Gyro Stabilised Compass system or a Trim Angle (clinometer) sensor mounted fore and aft.
3. Variable damping 0 - 99 seconds.

Fore and Aft trim ange (along with Heel Angle) is used by the main processor to correct Wind Sensor data.

2.12.17 Heading

Menu Heading:	NAVIGATE
Function Text:	HEADING
Update Rate:	2 Hz
Units:	Degrees magnetic or true

Notes

1. Adjustable damping, 0-99 sec.
2. Sector alarm available.
3. Sensor alignment calibration.
4. Moving card analogue meter available.
5. Halcyon display available.

This is the compass heading, derived directly from the electronic Fluxgate Compass. This input for the system allows calculation of True Wind Direction, dead reckoning and other course related navigation functions.

An available option is the Halcyon Display which permanently shows heading in digital form and has a segmented bar graph display to show off course.

The Halcyon 2000 Compass automatically corrects for deviation due to the vessel's magnetic fields.

2.12.18 Heading on Opposite Tack

Menu Heading:	PERFORM
Function Text:	OPP TACK
Update Rate:	1 Hz
Units:	Degrees magnetic or true

This gives the heading the vessel would be sailing when on the opposite tack with the same wind angle, and can be used in conjunction with a hand bearing compass to tell you when you are on the layline. It is calculated from Heading and True Wind angle.

2.12.19 Head Lift Trend

Menu Heading:	WIND
Function Text:	LIFT/HDR
Update Rate:	1 Hz
Units:	Degrees

Notes

1. Requires Halcyon Display.
2. Analogue indicator available.

This function is particularly useful to racing yachtsmen when sailing up wind. Port and starboard reference courses are entered into the Halcyon Display and used to calculate whether the boat is being lifted or headed. It is resettable from the FFD using the following sequence:

WIND → LIFT/HDR, **CONTROL → RESET**

2.12.20 Heel Angle

Menu Heading:	PERFORM
Function Text:	HEEL
Update Rate:	1 Hz
Units:	Degrees

Notes

1. Adjustable for horizontal sensor alignment.
2. Requires Halcyon Gyro Processor system or Heel Angle (clinometer) sensor.
3. Variable damping 0 - 99 seconds.

Heel Angle (along with Fore and Aft Trim) is used by the main processor to correct Wind Sensor data.

2.12.21 Leeway

Menu Heading:	NAVIGATE
Function Text:	LEEWAY
Update Rate:	1 Hz
Units:	Degrees

Note

Requires clinometer for heel.

Leeway is the angle between the boats heading and its course through the water. The difference is caused by the sideways slip that the boat has when going upwind. For the Hydra to be able to measure this it needs to know the heel angle, and hence a clinometer must be fitted. Leeway is of great importance in the calculation of Dead Reckoning, since leeway can considerably affect the dead reckoned position.

2.12.22 Layline Distance

Menu Heading:	PERFORM
Function Text:	LAYLINE
Update Rate:	Provided by position fixer
Units:	Nautical miles

Note

Requires NMEA 0183 interfaced position fixing system transmitting the ZDL sentence.

If tacking upwind or downwind to a waypoint, this function displays the distance of both left and right-hand laylines by alternating the display between the two. An L or an R is shown in the right-hand digits to signify Left or Right laylines respectively. This function is useful when nearing a waypoint. When the value reaches zero, it is time to tack or gybe for the mark. The calculation should be corrected for any tidal offset.

2.12.23 Local Time of Day

Menu Heading:	TIME
Function Text:	LOC TIME HR
Update Rate:	Provided by position fixer
Units:	Hours, minutes, seconds

Notes

1. Requires NMEA 0183 interfaced position fixing system transmitting the ZLZ sentence.
2. Check that the Local Time Offset is entered into the position fixer correctly.

The function normally shows the Local Time of Day in hours and minutes as given by the position fixer. To reveal minutes and seconds press the **Enter** Key once. A further press of the **Enter** Key returns the display to hours and minutes.

2.12.24 Loadcell

Menu Heading:	LOADCELL
Function Text:	Selected in hardware
Update Rate:	1 Hz
Units:	Tonnes, Klb

Notes

1. Requires digital amplifier.
2. Calibration available.

System for accurate measurement of load rigging pins that are in shear.

2.12.25 Mast Angle

Menu Heading:	PERFORM
Function Text:	MAST ANG
Update Rate:	1 Hz
Units:	Degrees

Notes

3. Requires mast rotation sensor.
4. Offset calibration available.

Required for yachts with rotating masts, such as multi-hulls, that have the mast rotation sensor fitted. It measures the angle between the mast and the centreline of the yacht, i.e. the angle it is twisted off the centreline.

2.12.26 Measured Wind Angle

Menu heading:	WIND
Function text:	MEAS W/A
Update rate:	2Hz
Units:	Degrees

Notes

1. Alignment calibration.

The Measured Wind Angle is the angle measured by the Masthead Unit sensor and corrected by alignment calibration. Measured Wind is not used whilst sailing, but is a useful function for checking the operation of Wind instruments before additional corrections are applied to the data.

2.12.27 Measured Wind Speed

Menu heading:	WIND
Function text:	MEAS W/S
Update rate:	2Hz
Units:	Knots

Notes

1. Anemometer calibration.
2. Offset Correction.

The Measured Wind Speed is the angle measured by the Masthead Unit sensor and corrected by alignment calibration. Measured Wind is not used whilst sailing, but is a useful function for checking the operation of Wind instruments before additional corrections are applied to the data.

2.12.28 Next Waypoint Distance

Menu Heading:	WAYPOINT
Function Text:	NEXT WPT NM
Update Rate:	Provided by position fixer
Units:	Nautical miles

Note

Requires NMEA 0183 interfaced position fixing system transmitting the WDC sentence.

This is the distance in nautical miles from the current selected waypoint on your position fixer to the next waypoint on route.

2.12.29 Off Course

Menu Heading:	NAVIGATE
Function Text:	OFF CRSE
Update Rate:	1 Hz
Units:	Degrees magnetic or true

Notes

1. Requires Halcyon Display.
2. Analogue Indicator available.

This function is available when a Halcyon Display is connected to the system. The amount off course is indicated on the Halcyon bar graph and shown numerically on other Hydra displays.

A dedicated analogue indicator is also available. For further information see Part 5 - Options.

It is resettable using the following sequence:

NAVIGATE → OFFCRSE, **CONTROL** → **RESET**

2.12.30 Rudder Angle

Menu Heading:	MISC
Function Text:	RUDDER
Update Rate:	1 Hz
Units:	Degrees

Notes

1. Requires rudder angle sensor.
2. Offset calibration available.

This function is used to indicate to the Trimmers how well the boat is balanced.

2.12.31 Sea Temperature

Menu Heading:	TEMP
Function Text:	SEA TEMP
Update Rate:	1 Hz
Units:	Degrees Centigrade or Fahrenheit

Notes

1. Requires temperature sensor.
2. Audible high/low alarm available.

Useful on long distance sailing when ocean currents are discerned by changes in water temperature. It can be useful in other ways too. Often the water flowing out of rivers differs in temperature quite markedly to the sea, and this may help you pick up the favourable current.

2.12.32 Speed Over Ground

Menu Heading:	WAYPOINT
Function Text:	SPD O/G
Update Rate:	Provided by position fixer
Units:	Knots

Note

Requires interfaced position fixing system.

This also comes straight from the position fixing system, and is available, provided it is sent, when the position fixer is connected. Comparing the speed over ground to the speed you are doing through the water is a key tactical tool. This is particularly so in strong tidal waters and at night, when the only indication that the tide has changed and you are no longer making progress is the speed over ground.

2.12.33 Stored Log

Menu Heading:	LOG
Function Text:	STD LOG
Update Rate:	1 Hz
Units:	Nautical miles

The stored log runs continually, and is always available as an accumulative total of the boat's miles. It is not resettable, the trip log is used for this purpose.

Normally the Log function displays nautical miles to two decimal places, i.e. 99.99nm (maximum). One press of the **Enter** Key expands the display to 0099nm giving a maximum available display of 9999nm if required.

2.12.34 Tidal Rate and Drift

Menu Heading:	NAVIGATE
Function Text:	TIDE SET or TIDE RTE
Update Rate:	1 Hz
Units:	Degrees magnetic, knots

Notes

1. Damping 0-99 minutes.
2. Calibration: Magnetic variation.
3. Some position fixers output the current local magnetic variation on the NMEA 0183 port using either HVD, HVM, RMA or RMC sentences. As a result, CAL VAL 1 on the TIDE SET function will automatically set to the correct variation.

Your position fixer will either supply a true or magnetic bearing to the Hydra 2000. If it supplies true bearing then you must enter the magnetic variation into the Hydra 2000. It is found in the menu under:

NAVIGATE → TIDE SET, **CALBRATE → CAL VAL 1 (MAG VAR)**

Note

If your position fixer sends magnetic bearing, check that the variation is correctly entered into it.

The calculation involves comparing the course and speed over the ground, from the position fixer, to the course and speed of the boat through the water, from dead reckoning. Any differences are due to the tidal set and drift and can be displayed as such. To make this accurate the dead reckoning really requires Leeway input and this in turn requires a heel angle sensor to measure heel angle.

The damping on this function is adjustable and this can be important. In rapidly changing tidal situations you need to lower the damping right down to be able to see changes quickly. Conversely in a steady tide or current the longer time the calculation is averaged over, the more accurate the results will be. The lag in the position fixer's ability to adjust to rapid changes in direction, such as tacks, should also be considered when using the results of this function. When making numerous tacks, readings should be treated with caution.

2.12.35 Timer

Menu Heading:	TIME
Function Text:	TIMER
Update Rate:	1 Hz
Units:	Hours, minutes and seconds

Note

Individually resettable.

Used to time the start and to record elapsed. The timer will act as either a stopwatch or countdown.

Pressing the **Enter** Key will toggle the display between min/secs and hrs/mins as indicated on the display.

2.12.36 Time to Layline

Menu Heading:	TIME
Function Text:	TIME L/L
Update Rate:	Provided by the position fixer
Units:	Hours, minutes, seconds

Note

Requires NMEA 0183 interfaced position fixing system transmitting the ZDL sentence.

This function is linked to layline distance. The information displayed shows the time to go before reaching the appropriate layline. A value of zero indicates time to tack or gybe.

2.12.37 Time to Waypoint

Menu Heading:	WAYPOINT
Function Text:	ETA WPT
Update Rate:	Provided by position fixer
Units:	Hours, minutes

Notes

1. Also gives ETA.
2. Requires interfaced position fixing system. Calculated directly by the position fixer, based on an assumed constant speed over the ground towards the mark.

2.12.38 Trip Log

Menu Heading:	LOG
Function Text:	TRIP LOG
Update Rate:	1 Hz
Units:	Nautical miles

Note

Individually resettable.

This is the resettable log for recording trip distance and reads from the moment it is started, in nautical miles. It must be remembered that this is the distance sailed through the water, not over the ground. It also forms part of the calculation for Average Speed. A useful feature is that if it is reset prior to the start of a race, then when the Timer counts down to zero, the trip log (and any other trip functions that have been reset) start automatically.

The trip log display can be expanded to display a maximum of 9999 nautical miles by pressing the **Enter** Key.

2.12.39 True Wind Angle

Menu Heading:	WIND
Function Text:	TRUE W/A
Update Rate:	1 Hz
Units:	Degrees

Notes

1. Relative to the boat's heading.
2. Corrected for masthead and other errors via the Look-up Table (see Part 3 - Calibration).
3. Variable damping 0-99 seconds.

The true wind is calculated from the vector triangle shown in Fig. 2.4. This uses the apparent wind speed, apparent wind angle and the Boat Speed in the calculation. The results are then corrected by the true wind correction tables, which are detailed in Part 3 - Calibration.

Note

The true wind is the wind relative to the water, and is not the same as the ground wind, unless there is zero tide or current. The true wind angle is the angle between the boat's heading and the true wind.

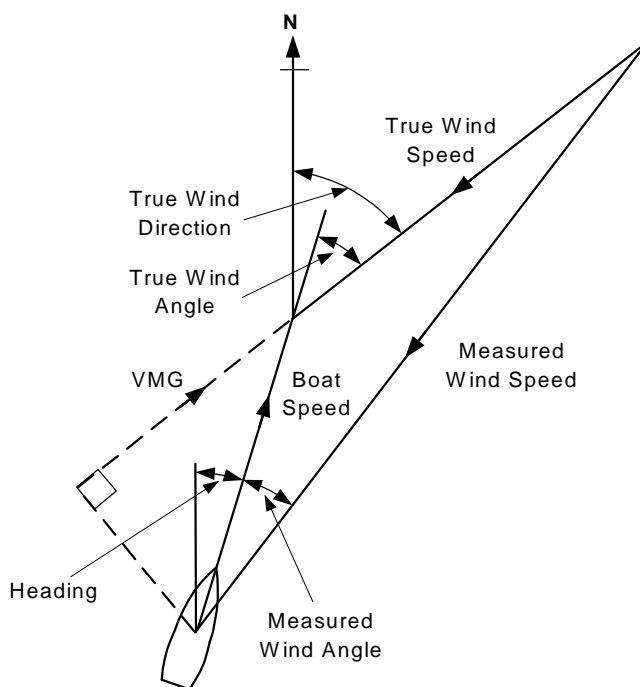

Fig 2.4 - Wind Angle

2.12.40 True Wind Direction

Menu Heading:	WIND
Function Text:	TRUE DIR
Update Rate:	1 Hz
Units:	Degrees magnetic

Notes

1. Wind angle relative to magnetic compass point.
2. Corrected for masthead and other errors via a Look-Up Table (see Part 3 - Calibration).
3. Damping control via true wind speed.

This is the tactician's greatest ally in the search for the right wind shifts. It shows the compass direction of the wind regardless of the boat's heading or speed. True wind direction is calculated from the true wind angle and heading, and is corrected for calibration errors by the true wind look-up table. A full explanation is given in Part 3 - Calibration.

2.12.41 True Wind Speed

Menu Heading:	WIND
Function Text:	TRUE W/S
Update Rate:	1 Hz
Units:	Knots, metres per second

Notes

1. Corrected for masthead and other errors via a Look-Up Table (see Part 3 - Calibration).
2. Variable damping 0-99 seconds.

When the boat is sailing downwind, the air passing over the mast is accelerated and tends to make the true wind speed over-read downwind. The Hydra has a calibration to correct for this which is explained in Part 3 - Calibration.

2.12.42 Velocity Made Good (VMG)

Menu Heading:	SPEED
Function Text:	VMG
Update Rate:	1 Hz
Units:	Knots

Note

Upwind and Downwind.

Velocity Made Good (VMG) is calculated from the true wind angle and the Boat Speed as shown in Fig 2.5. VMG is a measure of your performance upwind and downwind and is more important than Boat Speed, since it takes into account how close you are sailing to the wind. However, it is not possible for the helmsman to sail to it directly because of the momentum of the boat.

As you sail closer to the wind the VMG will initially rise, because the boat will hold its speed due to its momentum. So VMG increases and the helmsman, seeing this, would be encouraged to sail even higher to increase the VMG even more. Of course if you carry on like this you will eventually end up head to wind, the boat will stop dead and the VMG will plummet.

Whilst VMG is an important measure of performance it is best if it is watched by someone other than the helmsman. This person should develop a feel for the Boat Speed when the greatest VMG is attained and then communicate these to the helmsman.

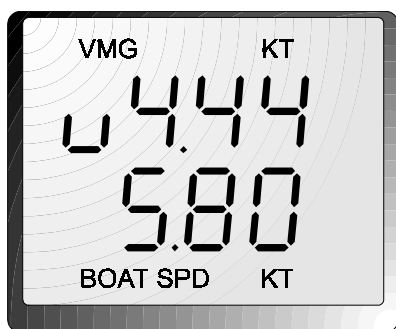

True Wind Direction

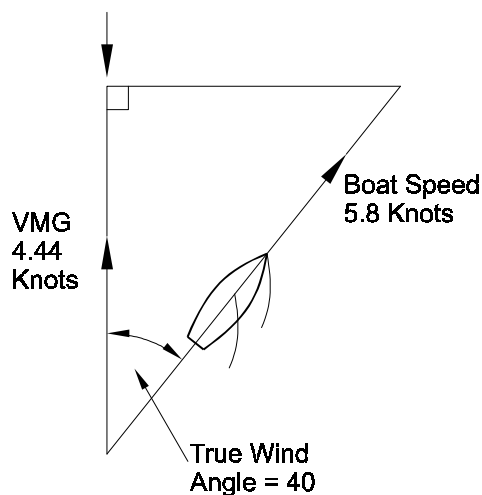

Up Wind

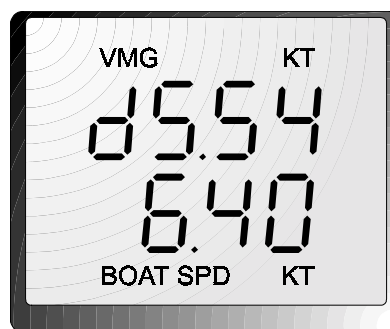

True Wind Direction

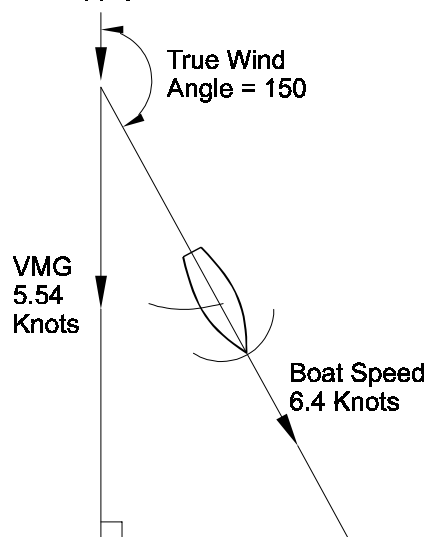

Down Wind

Fig 2.5 - Calculation of VMG

2.12.43 Wind Angle to the Mast

Menu Heading:	PERFORM
Function Text:	W/A MAST
Update Rate:	1 Hz
Units:	Degrees

Note

Requires mast rotation sensor if a rotating mast is installed.

When the mast rotation sensor is fitted, this measures the apparent wind angle to the mast's centreline, thus giving the actual angle of attack of the sail.

PART 3 - CALIBRATION

CONTENTS

Para		Page
3.1	INTRODUCTION	3-3
3.2	BOAT SPEED/LOG CALIBRATION	3-3
3.2.1	Principle of Log Calibration	3-3
3.2.2	Preparation for Log Calibration	3-4
3.2.3	Calibration Runs	3-4
3.2.4	Log AUTO CAL Facility	3-4
3.2.5	Log AUTO CAL Procedure	3-5
3.2.6	Manual Calibration	3-6
3.2.7	Boat Speed Calibration (ref. to a Known Value)	3-7
3.2.8	Boat Speed Calibration (Knots, MPH, KPH)	3-7
3.3	MEASURED WIND SPEED/ANGLE CALIBRATION	3-8
3.3.1	Principles of Wind Speed/Angle Calibration	3-8
3.3.2	Wind Angle Calibration (AWA)	3-9
3.3.3	Wind Speed Calibration	3-9
3.4	COMPASS CALIBRATION	3-11
3.4.1	Principles of Compass Calibration (Halcyon 2000 & Halcyon Gyro Stabilised Compasses)	3-11
3.4.2	Heading Node Selection	3-12
3.4.3	Halcyon 2000 Calibration Procedure	3-13
3.4.6	Halcyon Gyro Stabilised Compass Calibration Procedure	3-14
3.4.5	Halcyon Gyro Processor Setup	3-16
3.4.6	Halcyon Processor NMEA Output	3-16
3.5	HEEL ANGLE/LEEWAY CALIBRATION	3-17
3.5.1	Heel Angle Calibration	3-17
3.5.2	Leeway Calibration	3-17
3.5.3	Heel and Trim Angle with the Halcyon Gyro Stabilised Compass	3-19
3.6	TRUE WIND CORRECTION	3-19
3.6.1	True Wind Direction Calibration	3-19
3.6.2	True Wind Speed Calibration	3-23
3.7	DEPTH CALIBRATION	3-23

CONTENTS (Contd.)

Para		Page
3.8	BATTERY VOLTS CALIBRATION	3-24
3.9	SEA TEMPERATURE CALIBRATION	3-24
3.9.1	Sea Temperature Offset Calibration	3-25

ILLUSTRATIONS

Fig No		Page
3.1	Log Calibration Runs	3-5
3.2	Masthead Unit Alignment	3-10
3.3	Leeway Angle Measurement	3-18
3.4	True Wind Direction	3-20
3.5	Upwash	3-21
3.6	True Wind Direction Error	3-22
3.7	Depth Datum	3-24

TABLES

Table No		Page
3.1	Example of True Wind Angle Correction Table	3-21
3.2	Example of True Wind Speed Correction Table	3-23

PART 3 - CALIBRATION

3.1 INTRODUCTION

WARNING - Every care must be taken when undertaking any Calibration Procedure to ensure that the Hydra 2000 System is calibrated accurately and correctly. Incorrect calibration could lead to incorrect navigational information.

Calibration of an integrated instrument system is probably one of the most misunderstood, processes in the world of yachting. Rather in the way that fast sails badly trimmed will add little or nothing to the boat's performance, racing instruments badly calibrated, will also achieve very little. This part of the manual removes some of the mystique and breaks the calibration process down into a series of simple instructions. These instructions when carefully undertaken in the right order will consistently produce good results.

There are four basic inputs to your system that are fundamental to its integrated approach - Boat Speed, Compass Heading, Apparent Wind Angle and Apparent Wind Speed.

Without these four basic inputs, correctly calibrated, you cannot have the more interesting values of true wind speed and direction, and velocity made good, which are calculated from them. On any yacht the calibration of these items should be as high on the job list, after the launch, as making sure the sails fit. Finally, it is crucial to keep a full record of the process. Appendix 1 contains calibration tables designed specifically for recording your results.

3.2 BOAT SPEED/LOG CALIBRATION

3.2.1 Principle of Log Calibration

To calibrate the log it is necessary to work out the number of revolutions of a paddle-wheel, or sonic pulses per second that correspond to each knot of Boat Speed. The Boat Speed/Log calibration value is always shown as Hertz/Knot (Hz/Kt).

The Hydra 2000 allows you to calibrate both a single or a dual sensor unit. Under normal circumstances with a sensor mounted on the centreline the single calibration value should be all that is required.

However, if the sensor unit is not installed close to the centreline, or if dual paddle-wheels are installed, then calibration on each tack will be necessary. The Hydra 2000 will always use the calibration value for the leeward paddle-wheel/sensor, using the heel angle if it is fitted or the Apparent Wind Angle if it is not.

3.2.2 Preparation for Log Calibration

Before calibrating the log you should ensure that the underwater unit is correctly aligned as follows:

Paddle-wheel - The moulded arrows on top of the unit must be pointing forward along the fore and aft line of the hull. The unit must also be totally free of any weed or other fouling.

Ultrasonic Speed: The notch on the transducer is located in the cut-out in the housing.

Sonic Speed - Check that the unit is operating correctly as per the owner's manual.

3.2.3 Calibration Runs

Consecutive runs, under power, at a constant speed, should be made over a known distance. To eliminate the effect of tidal conditions, it is advisable to perform at least two runs, preferably three, along the measured track.

There are three available options for calibrating the log, Automatically (AUTO CAL), Manually (MANL CAL) or Reference (REF CAL).

3.2.4 Log AUTO CAL Facility

This facility enables the user to calibrate the yacht's log accurately and simply as all calculations are performed internally by the Main Processor. Referring to the Fig 3.1, A and B are the two markers for each run and X is the actual distance for each run as ascertained from the chart.

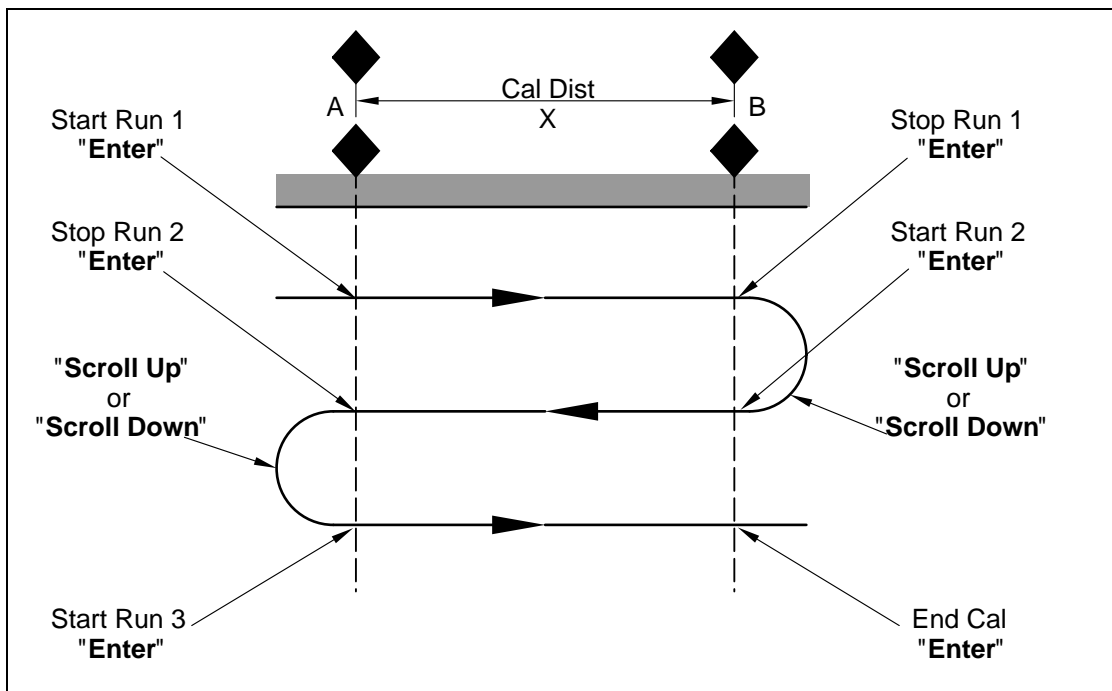

Fig 3.1 - Log Calibration Runs

The user is required to enter the distance X in nautical miles (CAL DIST) and then, as the yacht passes marks A and B on each run, to instruct the system to start (STRT RUN) and stop (STOP RUN) and finally to end calibration (END CAL) after the last required run is complete.

Note

The calibration process can be cancelled at any time during the operation by pressing the Page Key if the operator is not satisfied with the calibration runs underway, e.g., hampered by another vessel or wash, etc.

3.2.5 Log AUTO CAL Procedure

- (1) Select Boat Speed on the display.
- (2) If BOAT SPD is in Upper Display, press and hold **Scroll Down** to select CALBRATE. If BOAT SPD is in Lower Display, use **Scroll Up** to select CALBRATE.
- (3) Press **Enter**, display shows the current Boat Speed reading with AUTO CAL flashing.
- (4) Press **Enter**, display shows the current Boat Speed reading with SINGLE flashing.

(5) Press **Enter** twice, display shows the default setting for the actual calibration distance for each run along the given course.

(6) Press **Enter**, CAL DIST will flash. The **Scroll Up** and **Scroll Down** Keys can now be used to select the appropriate measured distance. Press **Enter** to accept new distance. The system is now ready to start the first calibration run.

(7) Press **Scroll Down**, STRT RUN appears, flashing.

(8) When crossing the first transit mark of the run, press **Enter**. The display now shows the current Boat Speed reading with STOP RUN flashing.

(9) When crossing the transit mark at the end of the run press **Enter**. The display shows the current Boat Speed reading with END CAL flashing.

(10) Press **Scroll Down** to select STRT RUN again then repeat steps (8) and (9).

(11) If only two runs are required, press **Enter** to end calibration. The Lower Display will now show the new calibration value that has automatically been calculated by the Main Processor. This should be recorded on the chart provided.

(12) If a third run is required, press **Scroll Down** to STRT RUN then repeat from step (8).

The yacht's log is now calibrated and the new calibration value is stored permanently in the computer's memory.

Note

"ERR" will be displayed if the system encountered a problem during the calibration run. For example, if the calibration distance was too short.

3.2.6 Manual Calibration

The calibration values can be adjusted directly as shown in 'Examples of Calibration' included in Part 2 - Operating Information.

3.2.7 Boat Calibration (ref. to a Known Value)

The following enhancement is only available when the Hydra Depth Unit is used in conjunction with the Hydra 2000 FFD Display version later than 5C.

To calibrate the Boat Speed by reference to a known value, e.g., another boat with an accurately calibrated log proceed as follows:

Select BOAT SPD KT on the upper half of the FFD Display.

- (1) Press **Scroll Down** until the lower text shows CALBRATE flashing.
- (2) Press **Enter**, the lower text now shows AUTO CAL flashing.
- (3) Press **Scroll Down** until the lower text shows REF CAL flashing.
- (4) Press **Enter**, the lower text now shows REF CAL along with current Boat Speed.
- (5) Press **Enter**, the lower text now shows REF CAL flashing and by use of the **Scroll Up/Down** the reference speed may be adjusted.
- (6) Press **Enter**, the new speed value is accepted and the upper display will show the re-calibrated boat speed.

3.2.8 Boat Speed Calibration (Knots, MPH, KPH)

To select and calibrate the required boat speed units proceed as follows:

- (1) Press **Scroll Up** until the upper text shows LOG flashing.
- (2) Press **Enter**, the upper text now shows STD LOG flashing.

(3) Press **Scroll Up** until the upper text shows TRIP LOG flashing.

(4) Press **Enter** until the upper text shows TRIP LOG and the current value.

(5) Press **Scroll Down** until the lower text shows CALBRATE flashing.

(6) Press **Enter**, the lower text now shows CAL VAL 1 flashing.

(7) Press **Scroll Down** repeatedly and the lower text will cycle through CAL VAL 1, CAL VAL 2, and CAL VAL 3.

When CAL VAL 1 is displayed:

(8) Press **Enter** and the lower text shows SPD KTS.

When CAL VAL 2 is displayed:

(9) Press **Enter** and the lower text shows SPD MPH.

When CAL VAL 3 is displayed:

(10) Press **Enter**, the lower text shows SPD KPH.

For whichever selection is made:

(11) Press **Enter**, the lower text now shows SPD KTS, SPD MPH, or SPD KPH with the current boat speed value in its original units.

(12) Press **Enter**, the current boat speed value, in its original units, will flash.

(13) Press **Enter**, the current boat speed will be converted to and displayed in the newly selected units.

3.3 MEASURED WIND SPEED/ANGLE CALIBRATION

3.3.1 Principles of Wind Speed/Angle Calibration

Wind shear and wind gradient can be a problem when calibrating Measured Wind Speed and Angle. It is easy to see how shear can affect the Measured Wind Angle; no sooner have you set it up than the shear changes and everything is out again. This can lead to a circular situation if you are not careful. The best solution is to do your calibration on a day when the shear is minimal and thereafter leave it as an indicator of the Wind Angle at the masthead, always remembering that this is not necessarily the wind angle that you are sailing at.

How do you know the shear is minimal? If you are finding it easier to attain speed on one tack than the other, then there is shear. A good look at the general weather conditions is also helpful. Do not calibrate in building sea breezes!

Wind gradient is the biggest culprit for getting true wind speeds accused of gross inaccuracy. The problem is that most people use the wind speed as a measure of the pressure which it is not. It is a measure of the wind speed at the top of the mast, and that is all. If it is 12kts at the top of the mast and only 4kts at the water, then the breeze will feel a lot softer and provide less power for the rig than if the breeze is twelve knots all the way down to the water.

This is why we recommend that the last thing you touch is the Measured Wind Speed. It is calibrated in the factory where wind tunnel calibrated units are available, and apparent inaccuracies are more likely attributable to effects such as wind gradient, rather than to a basic calibration problem.

3.3.2 Wind Angle Calibration (MWA)

To discover the MWA alignment error we can employ one of two techniques. The first is simply to go head to wind and read the value of the Measured Wind Angle. If it reads anything other than 0, you have an error. For example, if the Measured Wind Angle reads 4° then you should enter -4 as the calibration value. If it is less than 0 then the opposite applies.

The second method involves a sailing trial as shown in Fig 3.2 - Masthead Unit Alignment.

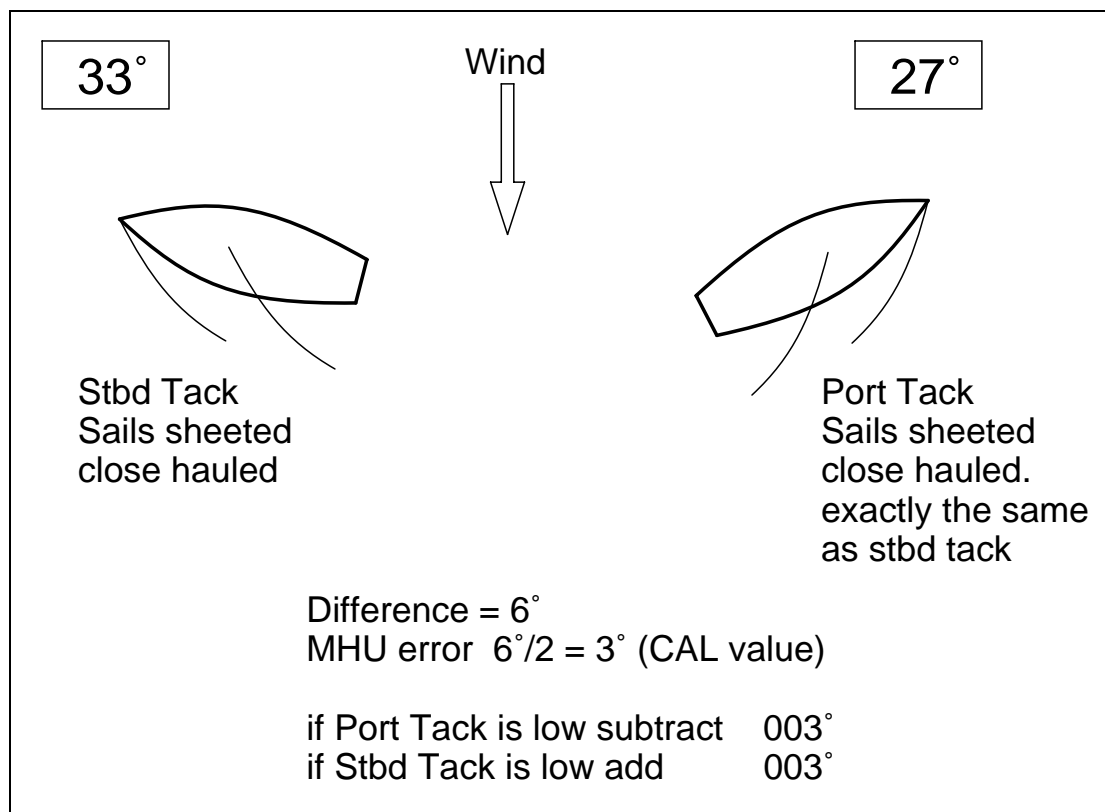

Fig 3.2 - Masthead Unit Alignment

- (1) Whilst monitoring MEAS W/A on a display, sail upwind at the optimum close hauled angle.
- (2) When conditions are steady, write down the mean MEAS W/A reading.
- (3) Tack the vessel and sail at the optimum close haul position as before.
- (4) When conditions are again steady, write down the mean MEAS W/A reading.
- (5) Repeat steps (1) to (4) inclusive at least two or three times to obtain an average MEAS W/A for each tack.
- (6) Calculate the angle difference between the port and starboard tacks and divide the result by two to give the MHU alignment error for entry into the system. If the readings were less on port than on starboard tack, the value to be entered should be negative as denoted by the minus sign in the left of the calibration value.

The calibration value is entered into the system via the menu choice:

WIND → MEAS W/A, **CALBRATE** → **MHU ANGL**

Full details are given in 'Examples of Calibration' contained in Part 2 - Operating Information.

3.3.3 Wind Speed Calibration (MWS)

Although you are strongly discouraged from changing the measured wind speed calibration, should you need to do it, then the changes are made in the system menu under:

WIND → MEAS W/S, **CALBRATE** → **MHU CAL**

and

WIND → MEAS W/S, **CALBRATE** → **MHU OFFS**

3.4 COMPASS CALIBRATION

3.4.1 Principles of Compass Calibration (Halcyon 2000 & Halcyon Gyro Stabilised Compasses)

B&G's Autoswing Compasses contain software that allows them to record the magnetic fields in the yacht that are causing the deviation errors. It calculates the corrections every time the boat completes a 360° turn, provided the following conditions are met:

- (a) The 360° turn - Halcyon 2000 & Halcyon Gyro Stabilised Compass is completed in the same direction.
- (b) The rate of change of heading does not exceed 3°/s; i.e. the turn should take about 3 minutes to complete.
- (c) The rate of change of heading must not fall below 0.2 of a degree per second during the 360° turn, i.e. the 360° turn must not take longer than 12 minutes.
- (d) The rate of change in heading is constant.
- (e) The compass is installed in a location free from magnetic interference such as iron keels, engines, loudspeakers etc. Consideration should also be given to electrical cables which may carry excessive currents (e.g. navigation lights).

(f) The compass is installed in a location as close to the centre line of the boat as possible. Avoid areas such as the fore peak and the sides of the hull where the effects of pitch and roll are at their greatest.

(g) On steel hulled vessels, the compass will need to be installed above decks away from the effects of the hull. Ideally, the compass should be installed 4-5m (12-16ft) above deck level.

3.4.2 Heading Node Selection

The Hydra 2000 System can accept heading data from a variety of different sources. These different sources are known as Nodes and allow the system to identify which heading devices are connected to the system. The list below shows the various sources of heading available with its respective address node:

Device	Node
Halcyon Gyro Stabilised Compass	15
Halcyon 2000 Compass	16
Type PLC Pilot	17
Type ACP Pilot	18
NMEA Heading (NMEA FFD)	96

Enter the required heading node by following the procedure below:

- (a) Press the **Scroll Up** key until NAVIGATE is shown in the text, flashing.
- (b) Press **Enter**.
- (c) Press the **Scroll Up** key again until the display shows COURSE °M flashing.
- (d) Press **Enter**. COURSE °M will now stop flashing.
- (e) Press **Scroll Down** until the display shows CALBRATE.
- (f) Press **Enter** 3 times. The display now shows HDG NO and will display a value which flashes.
- (g) Use the **Scroll Up** and **Scroll Down** keys to change the value to the required setting.
- (h) Press **Enter**.
- (i) Switch the system off, and then back on again to complete the calibration process.

Notes

- (1) Hydra Pilots, Hercules Pilots, HS Pilots and Halcyon FFDs will also require the Heading Node to be set to your desired choice. Refer to the relevant user manual for further information.
- (2) 20/20 displays will require Heading to be re-selected. Simply re-select this function and refer to section 5.6.5 for more information.

3.4.3 Halcyon 2000 Calibration Procedure

- (1) Check for any magnetic devices placed near the compass, especially ones that are out of their normal places.
- (2) On a calm day select a stretch of open water with little traffic (so you will not have to take avoiding action which would ruin the calibration). The flatter the water and the less the wind the easier it will be to meet the conditions for calibration.
- (3) Check for any large steel structures nearby, that may cause additional, erratic deviations.
- (4) Scroll to the NAVIGATE menu and select COMP CAL on the top half of the display. The display shows OFF.
- (5) Press **Scroll Down** until the lower text shows CALBRATE flashing.
- (6) Press **scroll down** until the lower text shows CALIBRATE, press the **ENTER** key, and scroll down to CAL VAL 1, press enter and START will be displayed with '0' as a default value.
- (7) Press the **Enter** key once and the '0' starts to flash. Use the **Scroll Up** key to change the value to '1'.
- (8) Press the **Enter** key. The display now shows 000°.
- (9) At a speed not exceeding five knots, turn the boat through 360° at a rate not greater than 2-3° per second. The display will show the amount of turn completed so far. Continue to turn the boat until the display shows PASS or FAIL.

Notes

1. The compass calibration swing may be aborted at any time. To do this, press the **Enter** key once. Next, using the **Scroll Down** key change the value from '1' to '0', and then press **Enter** to store. The display will now show OFF.
2. The first time the system is switched on, or after a system reset, the Heading will alternate with CAL. This is to indicate to the user that the compass must be calibrated. This will disappear after the compass has been calibrated.

(10) Eliminate any constant error in heading. These are normally checked for by using shore-based transits, once the error is known it can be eliminated by entering the value into the Hercules under:

NAVIGATE → HEADING, **CALBRATE** → **CAL VAL1**

For example, the compass was reading 320 degrees and it should read 316, then the value to enter would be -4.

3.4.4 Halcyon Gyro Stabilised Compass Calibration Procedure

(1) Check for any magnetic devices placed near the compass, especially ones that are out of their normal places.

(2) On a calm day select a stretch of open water with little traffic (so you will not have to take avoiding action which would ruin the calibration). The flatter the water and the less the wind the easier it will be to meet the conditions for calibration.

(3) Check for any large steel structures nearby, that may cause additional, erratic deviations.

3 Scroll to the **MISC** menu and select HALCYON on the top display. GYRO will be displayed in the top data line if a Halcyon Gyro Stabilised Compass is connected.

4 Press **scroll down** until the lower text shows 'CALIBRATE' press the **ENTER** key

(6) Press **scroll down** until the lower text shows CAL VAL 1, press enter and START will be displayed with '0' as a default value.

(7) Press **enter** and the '0' starts to flash. Use the **scroll up** key to change the value to '1'.

(8) Press the **Enter** key. The display now shows 000°.

(9) At a speed not exceeding five knots, turn the boat through 360° at a rate not greater than 2-3° per second. The display will show the amount of turn completed so far. Continue to turn the boat until the display shows PASS or FAIL. If you receive FAIL you must re-calibrate your compass.

Notes

1. The compass calibration swing can be aborted at any time. To do this press the **enter** key once. Next press the **scroll down** key and change the value from '1' to '0'.
2. You can re-calibrate at any time by following the above procedures.

(1) If you have any constant error in your heading, you can correct for this.

Enter the value to offset your heading e.g. if your heading displays 100° and it should read 97°, then the value to enter would be -3.

The M indicates Magnetic reference headings and a T will indicate True referenced headings.

Heel Trim will be shown as the following:-

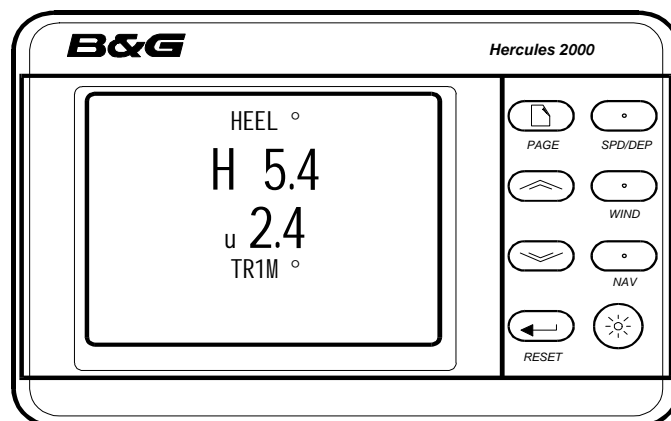

The H symbol will be placed on left indicating heel to port and on the right for heel to starboard. The display will always be shown to 1 decimal point

The U symbol on the left indicates that the bow is up, while a d will be shown indicating bow down. The display will always be shown to 1 decimal point

If you have any constant error in your heading, you can correct for this.

NAVIGATE → HEEL, **CALIBRATE → CAL VAL 1**
NAVIGATE → TRIM, **CALIBRATE → CAL VAL 1**

3.4.5 Halcyon Gyro Processor Setup

Data under the MISC → HALCYON heading describes the setup of the Halcyon Gyro Processor, and are as follows:

OFF	No heading source from either a Halcyon Gyro Stabilised Compass or a B&G system compass
GYRO	Receiving data from Halcyon Gyro Stabilised Compass or NMEA input to Halcyon Gyro Processor
SYS	Receiving data from a B&G system compass or NMEA input to NMEA FFD or performance processor
PASS	Calibration swing is complete
FAIL	Calibration swing failed and the compass needs to be re-calibrated.
xxx ⁰	Number of degrees turned during calibration swing

3.4.6 Halcyon Processor NMEA output setup

NMEA sentence output settings determine what sentences are output with respect to which heading source is available.

MISC→HALCYON, **CALIBRATE→CAL VAL 2 (NMEA MDE)**

0	HDT from Halcyon Gyro Stabilised Compass or NMEA input to Halcyon Gyro Processor
1	HDM from Halcyon Gyro Stabilised Compass or NMEA input to Halcyon Gyro Processor
2	HDG from Halcyon Gyro Stabilised Compass or NMEA input to Halcyon Gyro Processor

- 3 HDM/HDT from a B&G system [compass or NMEA input], or NMEA input to Halcyon Gyro Processor
- 4 HDG from a B&G system [compass or NMEA input], or NMEA input to Halcyon Gyro Processor

NOTE:

Mode 0 is the default value

Mode 3 will output the correct sentence depending on configuration.

Navigate →Heading, **CALIBRATE**→**CAL VAL 2**.

- 0 Magnetic
- 1 Auto (will set to True if Mag var is available, otherwise will stay in Magnetic)

If Mode 4 is selected and magnetic variation is not available then the magnetic heading will be output.

3.5 HEEL ANGLE/LEEWAY CALIBRATION

Calibration of Heel Angle and Leeway is only necessary if a Heel Angle Sensor is fitted to the yacht.

3.5.1 Heel Angle Calibration

The Heel Angle Sensor should be mounted as upright as possible, to read zero when the boat is upright. However any error can be removed by means of Heel Angle Calibration.

The heel angle should be recorded by a visual check from astern, on a calm day with the boat lying on slack warps in the dock, head to wind, all the gear stowed in its normal place, and anyone onboard standing on the centreline.

Under these conditions it should be zero, any error can be taken out by the Heel Angle Calibration by adding, or subtracting, the error from the existing calibration.

Heel Angle Calibration is to be found in the system menu under:

PERFORM → HEEL, **CALBRATE** → **CAL VAL1**

3.5.2 Leeway Calibration

Calibrating Leeway is difficult and it may be more accurate to consult the designer for the vessel's theoretical figure. In the absence of a figure a calculation of Leeway Coefficient can be made using the following formula:

$$L = \frac{K \times H}{Bs \times Bs}$$

where: Bs = Boat Speed
K = Leeway Coefficient
H = Heel Angle
L = Leeway Angle

K the constant that needs to be entered. To establish a value for leeway coefficient it is necessary to measure the leeway angle at a particular heel angle and boat speed. One method for this is shown In Fig 3.3 - Leeway Angle Measurement.

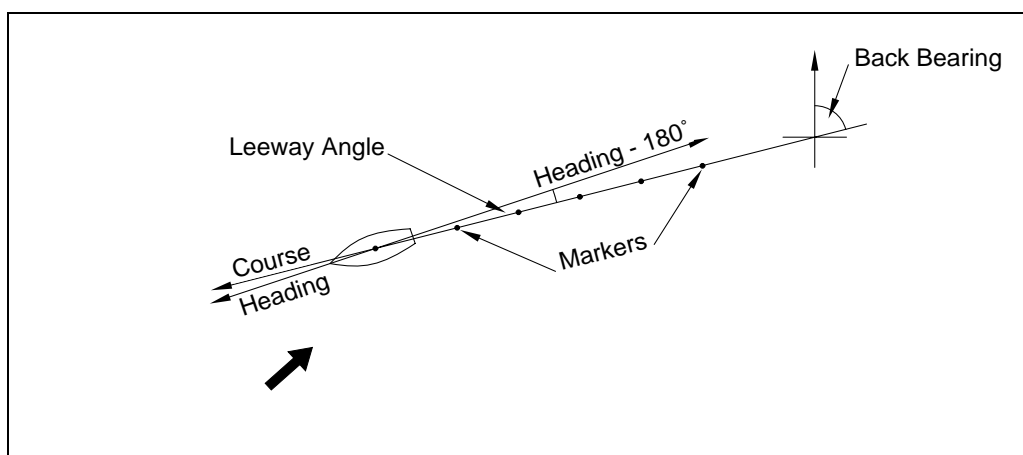

Fig 3.3 Leeway Angle Measurement

The idea is to sail on a steady course and drop markers over the stern at regular intervals, the angle between them and the centreline of the yacht is measured with a hand-bearing compass and hence leeway angle is measured. Whilst this is happening the boat speed and heel angle should be noted at intervals and an average calculated. These values can then be used to calculate the leeway coefficient from the following expression:

$$K = \frac{L \times Bs \times Bs}{H}$$

Once the leeway coefficient 'K' is known it is entered into the system under:

NAVIGATE → LEEWAY, **CALBRATE** → **CAL VAL1**

3.5.3 Heel and Trim angle with the Halcyon Gyro Stabilised Compass.

The heel and trim information from the Halcyon Gyro Stabilised Compass is displayed in the PERFORM menu.

The H symbol will be placed on left indicating heel to port and on the right for heel to starboard. The display will always be shown to 1 decimal point

The U symbol on the left indicates that the bow is up, while a d will be shown indicating bow down. The display will always be shown to 1 decimal point

Both heel and trim have an offset calibration to allow for any constant errors, adding or subtracting from CAL VAL 1 will correct this.

PERFORM → HEEL, **CALIBRATE → CAL VAL 1**
PERFORM → TRIM, **CALIBRATE → CAL VAL 1**

If you have heel and trim sensors connected to your system as well as a Halcyon Gyro Stabilised Compass then the Heel and Trim from the Compass will be used by default. If you wish to use your external sensors then set CAL VAL 2 to '0'.

PERFORM → HEEL, **CALIBRATE → CAL VAL 2**
PERFORM → TRIM, **CALIBRATE → CAL VAL 2**

3.6 TRUE WIND CORRECTION

It is finally time to go sailing and begin the calibration of the True Wind Speed and Direction. But before we begin the 'how' a short discussion of the 'why' is worthwhile.

Calibration of the True Wind Angle will also automatically correct the Apparent Wind Angle and Apparent Wind Speed values.

3.6.1 True Wind Direction Calibration

Why you need to have further calibration for True Wind Direction will become clear when you go sailing. The true wind might vary in direction from tack to tack, independently of any wind shifts. This phenomenon has come to be known as the true wind "tacking".

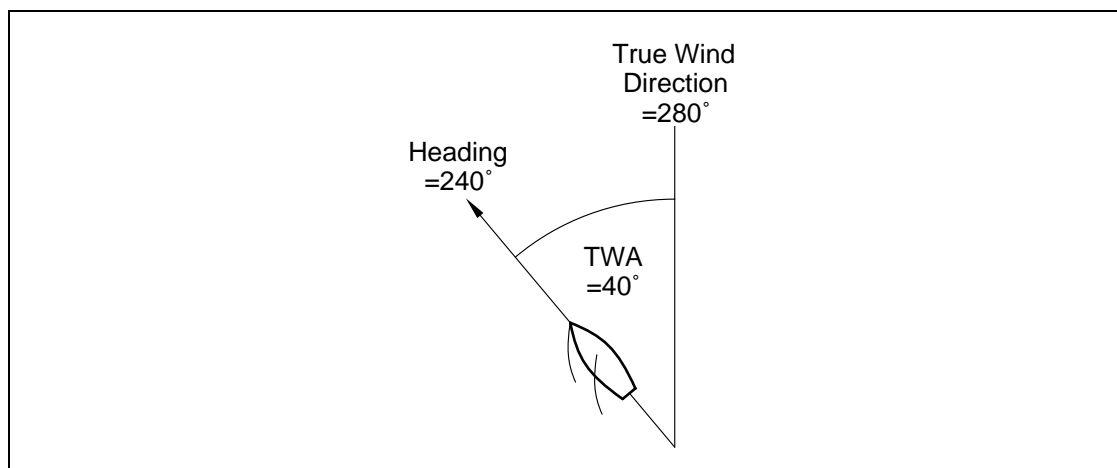

Fig 3.4 - True Wind Direction

The reason for this is a variety of errors when calculating the true wind angle from the measured wind angle.

The apparent wind that the instruments measure is actually deflected by the rig and sails from the 'real' apparent wind angle that we need to use to calculate the true wind. Add to this the various twisting effects of the mast and the Masthead Unit.

It is easy to see the true wind direction 'tack' as little as 2-3 degrees, which would mean the correction factors being as accurate as 0.5°, or about 1%. The Hydra 2000 has a simple, easy to use method for correcting these errors.

The problem stems from the true wind direction 'tacking' as the boat manoeuvres from tack to tack. We need to know the error that the true wind suffers in any manoeuvre, be it a normal upwind tack, a reach to reach tack, or a downwind gybe.

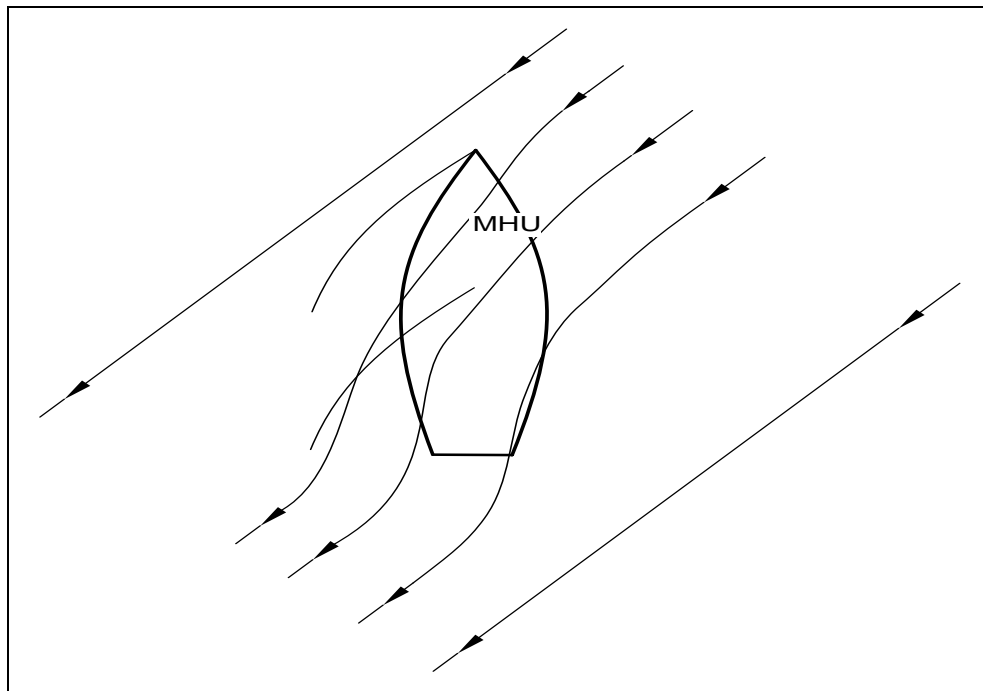

Fig 3.5 - Upwash

Once the error is known, it can be entered as a correction at the current true wind speed. The aim is to build up a table of corrections similar to that shown in Table 3.1 - Example of True Wind Correction Table.

	True Wind Speed					
	5	10	15	20	25	30
correctn (kt)	0	0	0	0	0	0
corr. angle	165	165	165	165	165	165

Table 3.1 - Example of True Wind Angle Correction Table

The formatted table (Table 3.1) is carried in the Hydra 2000 memory and it is necessary to determine and enter the relevant corrections for true wind direction. The correction is calculated empirically and from which some general rules can be determined.

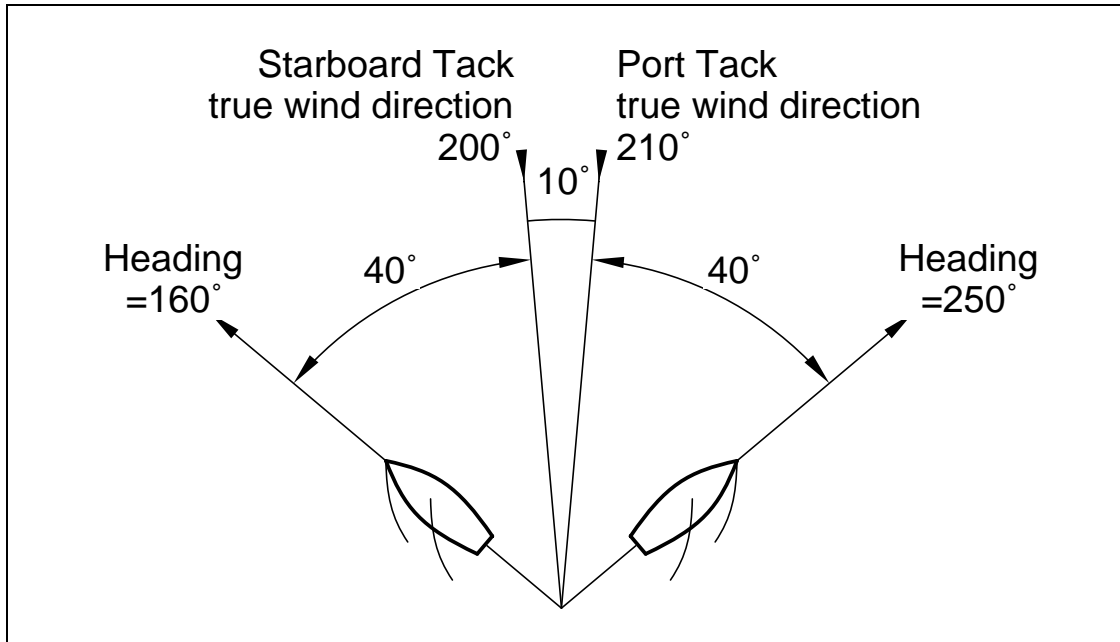

Fig 3.6 - True Wind Direction Error

Fig 3.6 is a typical situation, sailing on a port tack, upwind, in a ten knot wind, the true wind direction reads 210°. The vessel then tacks to starboard and is maintained on a steady course. The true wind direction now reads 200°. There is a 10° error tack to tack.

The true wind direction should read 205° on both tacks. To correct the true wind angle so that the true wind direction reads 205° on both tacks, 5° should be added to the true wind angle. As a general rule it can be said:

If you are lifted from Tack to Tack or Gybe to Gybe, then subtract half the difference.

The converse will apply:

If headed from Tack to Tack or Gybe to Gybe, then add half the difference.

The correction value at each point in the table is entered into the Hydra 2000 memory. The true wind correction facility, is then found in the menu by:

WIND → TRUE W/A, **CALBRATE** → **CORRECTION**

Using **Scroll Up** or **Scroll Down** until the one required value to be corrected is found. In this example it would be "upwind, 10 knots". Having scrolled through to this, press the **Enter** Key. This will allow entry of the required number of degrees correction (i.e. +5).

Use the **Scroll Up** and **Scroll Down** Keys to increase or decrease the value accordingly.

Pressing the **Enter** Key sets this figure in the Hydra 2000 memory.

At initial calibration it is important to enter the same value of correction to the wind speeds either side of the one you are using. This is to avoid the true wind direction jumping in value when the wind speed drops or increases outside the range you are correcting. When the table entries approach completion it will be possible to enter individual changes as other corrections will be accurate enough to avoid any strange "step" changes as the true wind speed varies.

It is very important to enter all these corrections into a Calibration Chart. In this way any large gaps in the correction table will be noticed where no entries have been made.

3.6.2 True Wind Speed Calibration

True Wind Speed suffers from another, mainly aerodynamic problem, where it tends to over-read downwind because of accelerated airflow over the top of the mast. It is possible to correct for this by applying a downwind correction to the True Wind Speed. This correction is applied at 180° true wind angle and then linearly interpolated to zero at 90° true wind angle. Bear away quickly from close-hauled to dead downwind and watch the increase in true wind speed. Then the difference is entered as a negative correction. The table will look similar to Table 3.2.

Wind Angle	True Wind Speed					
	5	10	15	20	25	30
Correctn (kt)	0	0	0	0	0	0
Corr. angle	165	165	165	165	165	165

Table 3.2 - Example of True Wind Speed Correction Table

The corrections are found in the menu under:

WIND → TRUE W/S, CALBRATE → CORRECTION

They are entered in the same way as the true wind direction corrections. Remember to enter the values on your correction chart in Appendix 1.

3.7 DEPTH CALIBRATION

A typical transducer installation is through the hull at a suitable position between the water line and the bottom of the keel. A DATUM (offset value) can be set, such that the depth display refers to either the water line or the keel line.

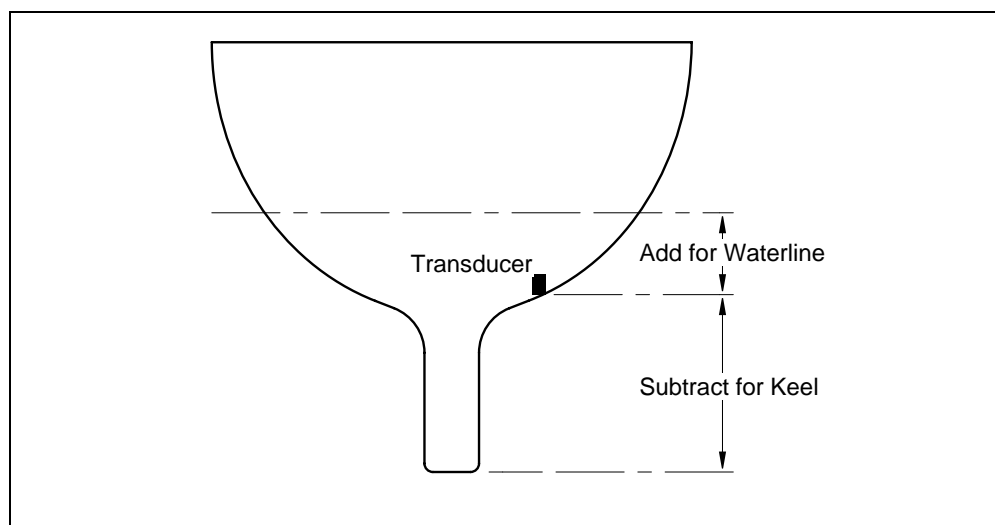

Fig 3.7 - Depth Datum

The datum is entered under:

DEPTH → DEPTH, **CALBRATE** → **DATUM**

3.8 BATTERY VOLTS CALIBRATION

The Hydra 2000 constantly monitors the yacht's battery supply which can be called up on any display, giving a reading in volts. This is calibrated by the manufacturer and should not require adjustment except in exceptional circumstances or after a system reset.

If it is necessary to calibrate this function a suitable voltmeter is required.

The calibration value is found in the menu in:

MOTOR → VOLTS, **CALBRATE** → **CAL VAL1**

Using the independent voltmeter, measure the battery supply at terminals 18 (+) and 17 (-) at the Computer Unit connection block. CAL VAL1 is altered to match the value from the voltmeter.

3.9 SEA TEMPERATURE CALIBRATION

If a suitable temperature sensor is fitted, the Hydra 2000 will monitor the current sea temperature. The paddle-wheel has a sensor incorporated within it, in this case no further action is required.

If the sensor is a totally independent fitting (B&G Part No. 223-00-027) then it is necessary to change the sensor selection value. This value is found in:

TEMP → SEA TEMP, **CALBRATE** → **CAL VAL1 (SENSORS)**

The default selection value is a 1, we need to change it to a 2.

3.9.1 Sea Temperature Offset Calibration

To calibrate SEA TEMP C or SEA TEMP F proceed as follows:

- (1) Select SEA TEMP C on upper half on FFD Display.
- (2) Press **Scroll Down** until the lower text shows CALBRATE flashing.
- (3) Press **Enter**, the lower text now shows CAL VAL 1 flashing.
- (4) Press **Scroll Down** the lower text now shows CAL VAL 2 flashing.
- (5) Press **Enter**, the lower text now shows OFFSET C.
- (6) Press **Enter**, the lower text now shows OFFSET C flashing and by use of **Scroll Up/Down** the temperature should be changed to the reference value.
- (7) Press **Enter**, the offset value is accepted and the upper display will show the adjusted measured temperature.

Similarly the above calibration can be carried out if SEA TEMP F is initially selected. The offset value is automatically converted so that both degrees °C and °F are adjusted correctly.

PART 4 - INSTALLATION INFORMATION

CONTENTS		
Para		Page
4.1	INTRODUCTION	4-3
4.2	INSTALLATION DATA SHEETS	4-4
	Sonic Speed Unit and Sonic Transducers	4-4
	Depth Transducer, Sonic Speed and Sea Temperature	4-5
	Multiple Linear Sensor Inputs	4-6
	Analogue Meters	4-7
	Alarm Unit, Network and Power Supply	4-8
	Network Terminator	4-9
	213 Masthead Unit	4-10
	Twin XTL Fins Gravity Switch	4-11
	Change-over Switch	4-12
	Hercules 2000 System Example Reference	4-13
	Depth Transducer and Paddle/Sea Temperature Sensor	4-14
	Hercules 2000 Performance Processor	4-15
	Clinometer and Barometric Pressure Sensor	4-16
	NMEA Full Function Display	4-17
	Non-NMEA Full Function Display	4-18
	Halcyon 2000 Compass	4-19
	Halcyon Gyro Processor with Halcyon Gyro Stabilised Compass	4-20
	Halcyon Gyro Processor with NMEA Gyro input	4-21
	Halcyon Gyro Processor as output Interface	4-22
	Ultrasonic Speed Sensor Unit	4-23

Intentionally Left Blank

PART 4 - INSTALLATION INFORMATION

4.1 INTRODUCTION

This part of the manual contains information relating to the interconnection of the units that make up the Hydra 2000 System. It is provided to enable a qualified technician to fault find or undertake the installation of additional units and thereby increase the number of functions available.

The information provided consists of drawing sheets showing equipment options and the interconnections between them. Also on the installation data sheets are details of cables, cable colours, instructions for installation and notes to assist the technician.

The installation sheets following are:

1. Sonic Speed Unit and Sonic Transducers
2. Depth Transducer, Sonic Speed and Sea Temperature
3. Multiple Linear Sensor Inputs
4. Analogue Meters
5. Alarm Unit, Network and Power Supply
6. Network Terminator
7. 213 Masthead Unit
8. Twin XTL Fins Gravity Switch
9. Change-over Switch
10. Hydra System Example Reference
11. Depth Transducer and Paddle/Sea Temperature Sensor
12. Hercules Performance Processor
12. Clinometer and Barometric Pressure Sensor
13. NMEA Full Function Display
14. Non-NMEA Full Function Display
15. Halcyon 2000 Compass
16. Halcyon Gyro Processor
17. Halcyon Gyro Processor NMEA Gyro Input
18. Halcyon Gyro Processor Output Interface
19. Ultrasonic Speed Sensor Unit

Note

All cable screens should be connected under the metal clamp bar located on the processor case.

4.2 INSTALLATION DATA SHEETS

SONIC SPEED UNIT & SONIC TRANSDUCERS ELECTRICAL INSTALLATION SHEET

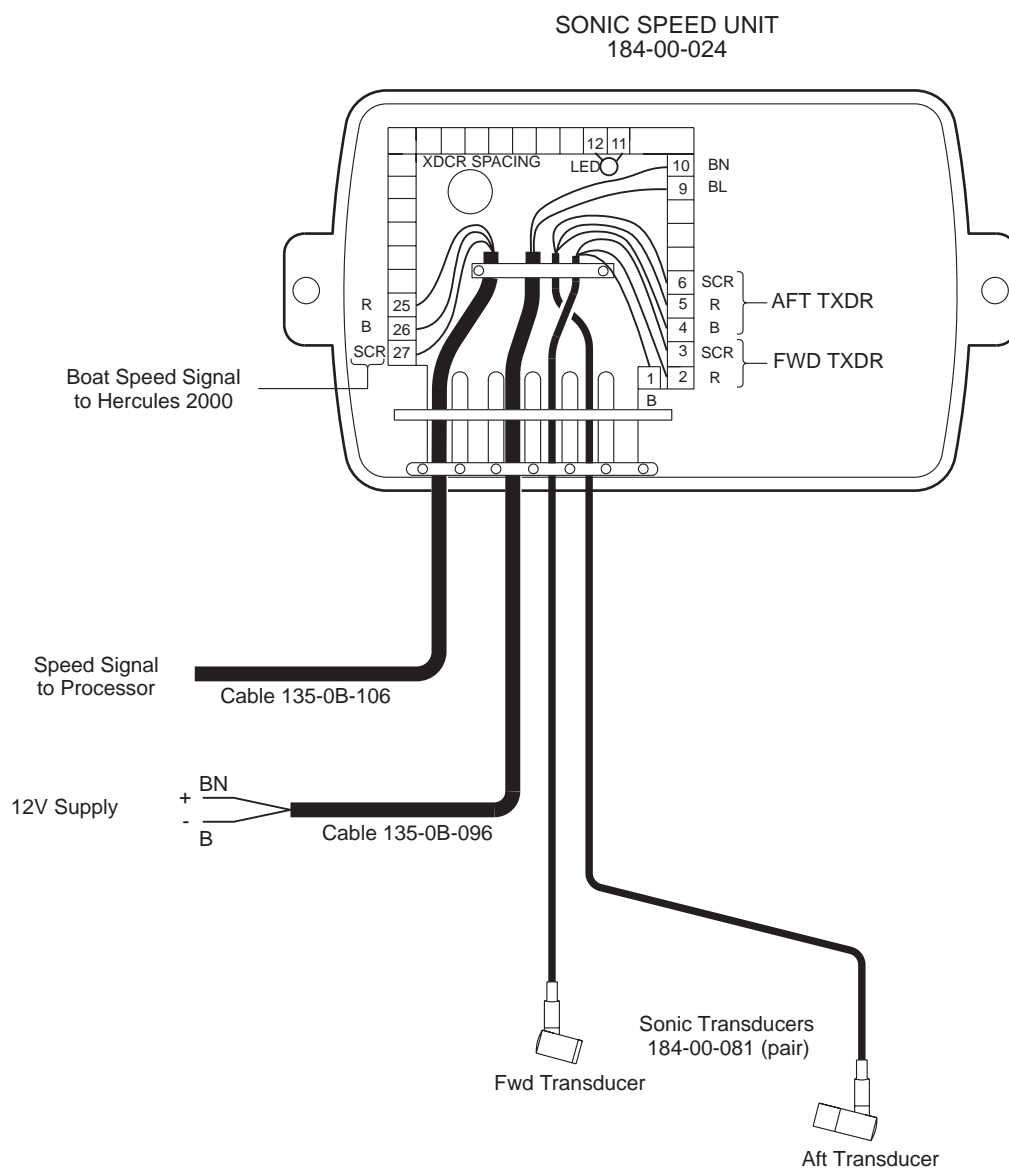

- To minimise interference the Sonic Speed Unit should be mounted away from high current carrying cables and components, e.g. starter motor, generators, etc.
- All cable screens must be connected as shown to minimise radio and radar interference
- The Sonic Speed installation must be setup and calibrated before use. The sonic transducers must be in water to do this. Refer to Sonic Speed Handbook IH-0222 for details.
- All cable runs to be clear of depth cables or any other cables likely to cause interference.
- The Sonic Transducer cables may be shortened as required (supplied length 5m).

DEPTH TRANSDUCER, SONIC SPEED AND
SEA TEMPERATURE SENSOR INSTALLATION SHEET

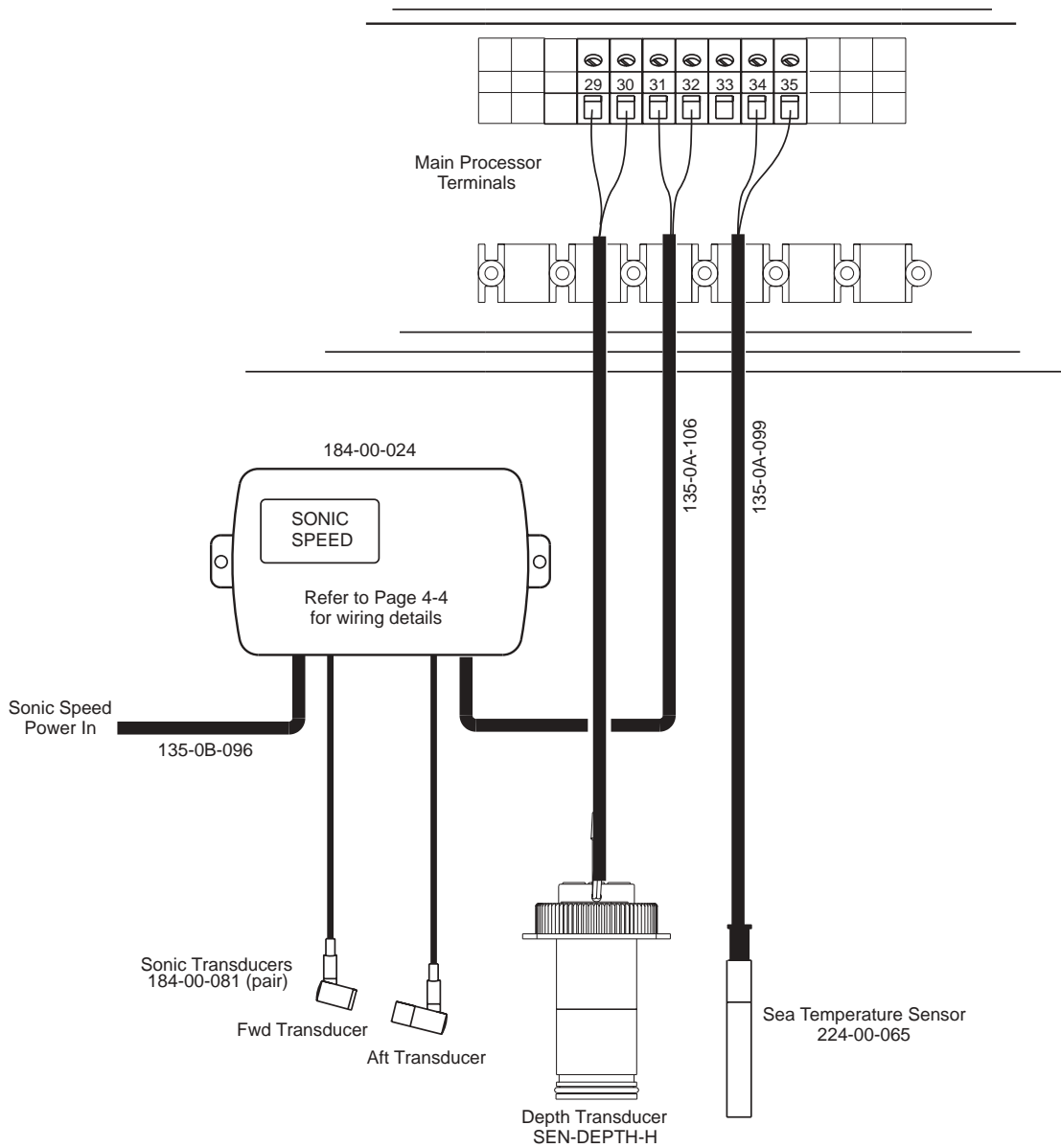

TERMINAL	FUNCTION	CABLE & WIRE COLOUR
	DEPTH TRANSDUCER	16m CABLE ATTACHED
29 30	DEPTH - DEPTH +	BLACK BLUE
	SONIC SPEED SIGNAL	15m CABLE (135-0A-106)
31 32	BOATSPEED -VE BOATSPEED +VE	BLUE RED SCREEN NOT CONNECTED
33	GROUND	NO CONNECTION
	SEA TEMP. SENSOR	9m CABLE ATTACHED
34 35	SEA TEMP. SUPPLY SEA TEMP. INPUT	RED GREEN BLUE NOT CONNECTED

**MULTIPLE LINEAR SENSOR INPUTS
INSTALLATION SHEET**

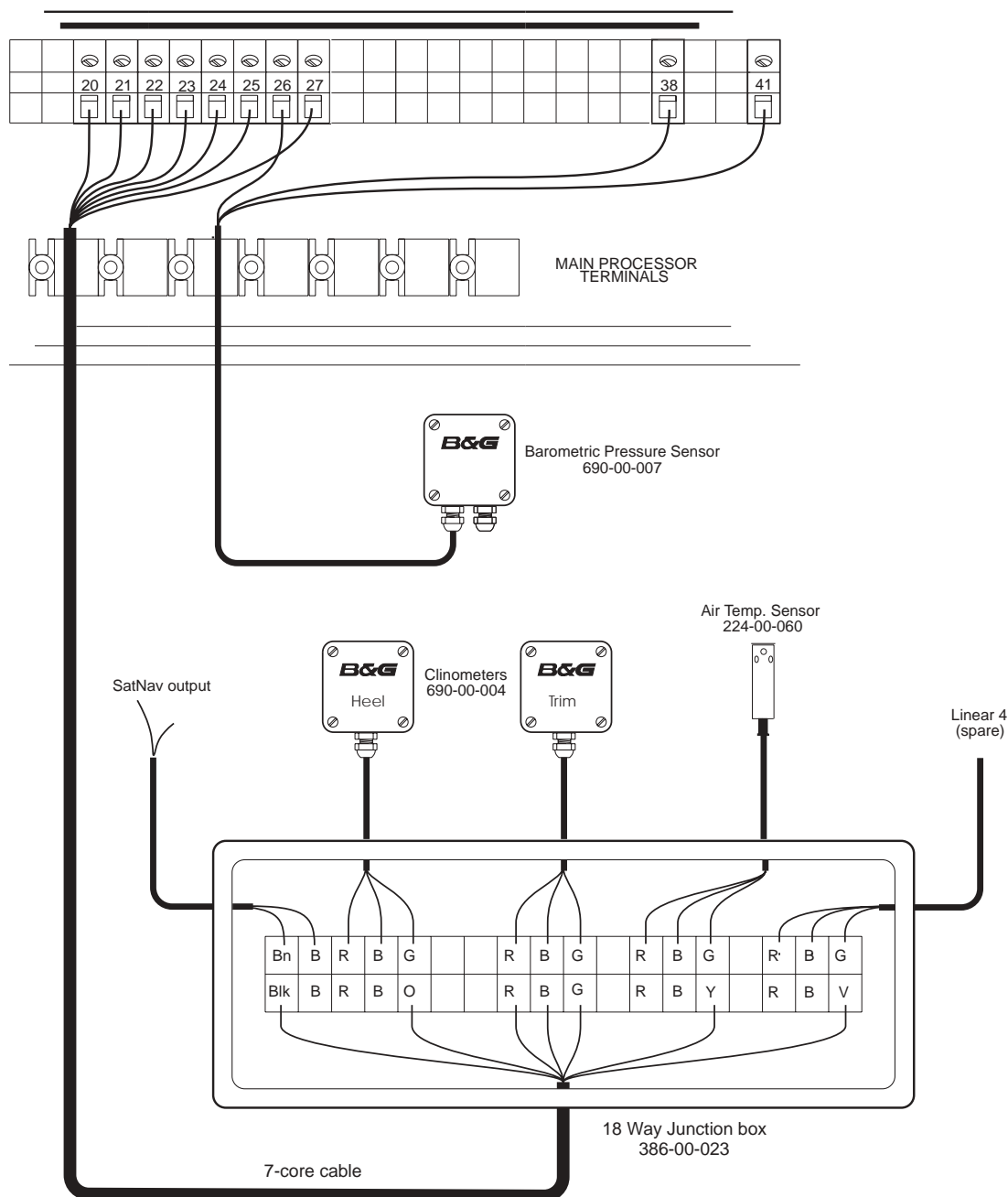

Notes

1. Inter-connect all sensor supply (Red wires) and sensor ground (blue wires) in the junction box. For clarity, these connections have been omitted from this diagram.
2. Rotary Mast Sensor (RRF-ACP) connections: Red=21; Blue=22, Green=27

Terminal	Function	Wire Colour	Cable
20	SatNav output	Black (Blk)	Use 7-core from processor to junction box
21	Sensor ground	Blue (B)	
22	Sensor Supply 6.5V DC	Red (R)	
23	Air temp. input	Yellow (Y)	
24	Heel sensor input	Orange (O)	
25	Trim sensor input	Green (G)	Sensors have cable attached
26	Baro. sensor input	Green (G)	
27	Lin. 4 sensor (spare)	Violet (V)	
38	Baro./Compass ground	Blue (B)	
41	Baro./Compass supply	Red (R)	

ANALOGUE METERS
ELECTRICAL INSTALLATION SHEET

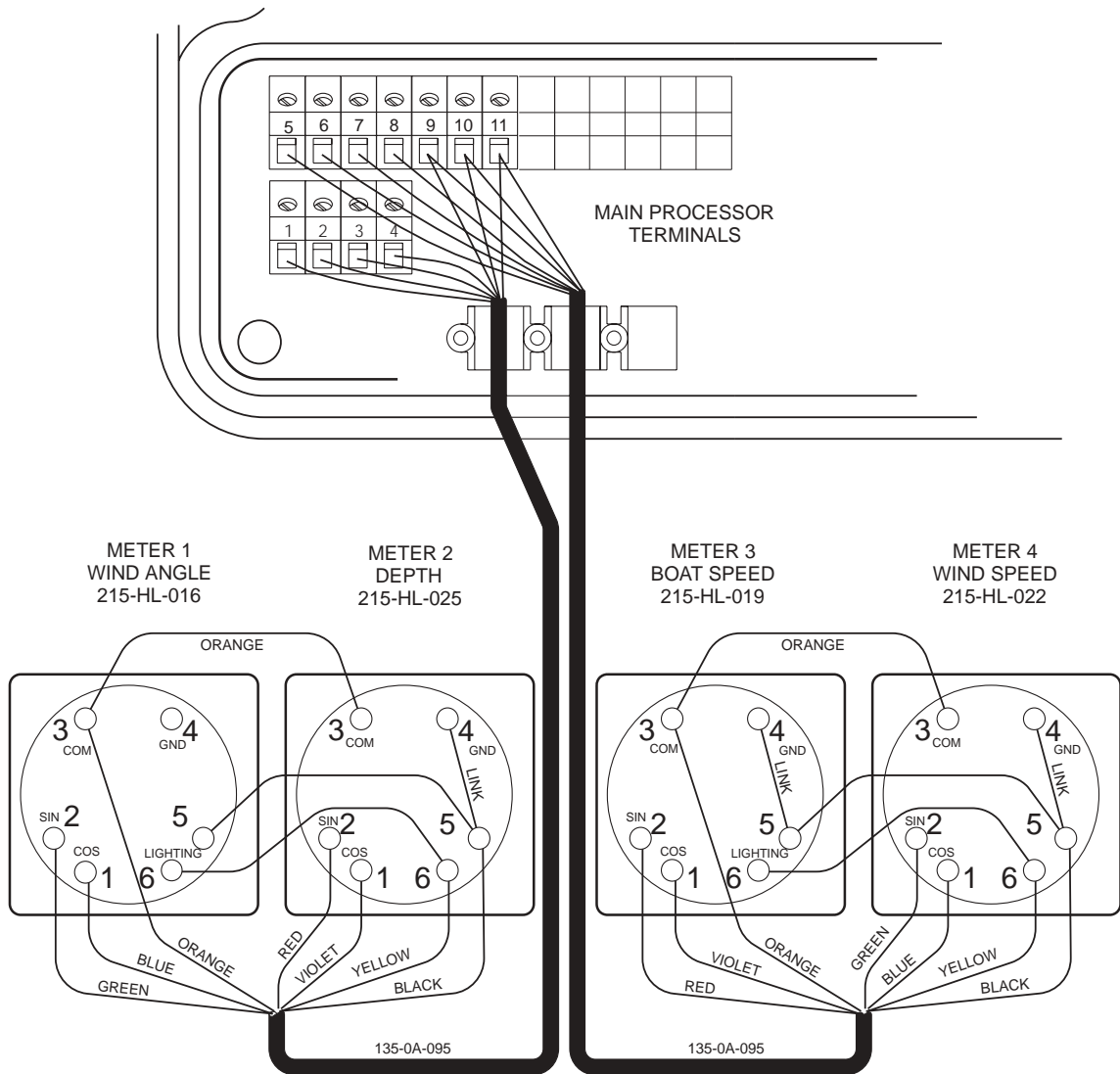

TERMINAL	FUNCTION	CABLE & WIRE COLOUR
	METERS 1 & 2	PART OF 19m CABLE 135-0A-095
1	METER 1 SIN WIND ANGLE	GREEN
2	COS WIND ANGLE	BLUE
3	METER 2 SIN DEPTH	RED
4	COS DEPTH	VIOLET
	METERS 3 & 4	PART OF 19m CABLE 135-0A-095
5	METER 3 SIN BOAT SPEED	RED
6	COS BOAT SPEED	VIOLET
7	METER 4 SIN WIND SPEED	GREEN
8	COS WIND SPEED	BLUE
	ALL METERS COMMON	
9	METER LIGHTING 12V	2 x YELLOW
10	METER COMMON	2 x ORANGE
11	METER GROUND	2 x BLACK

- Meters are shown in Factory set configuration. To reconfigure refer to section 5 of the Manual.
- "Return to Zero" meters must have terminals 4 and 5 linked; i.e. Boat Speed, Wind Speed, Depth, Rudder Angle and Heel Angle.

ALARM UNIT, NETWORK AND POWER SUPPLY
INSTALLATION SHEET

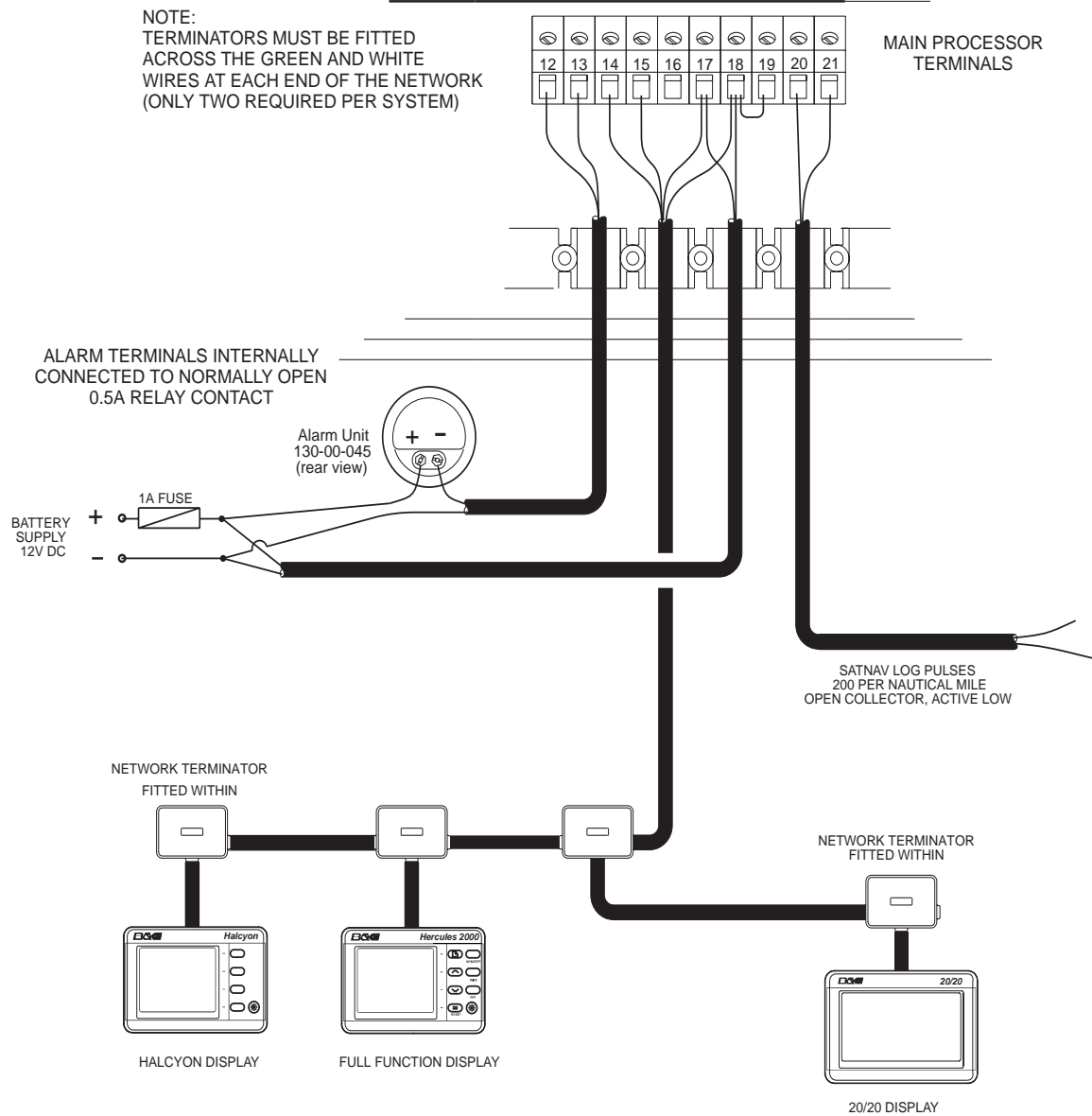

TERMINAL	FUNCTION	CABLE & WIRE COLOUR
12	ALARM UNIT	3m CABLE 135-0A-096
	ALARM	BLUE
13	ALARM	BROWN
	SYSTEM NETWORK	10m CABLE 135-0A-130
14	NETWORK DATA -	GREEN
15	NETWORK DATA +	WHITE
17	SUPPLY GROUND	BLACK
18	12V DC SUPPLY	RED
17	POWER SUPPLY	3m CABLE 135-0A-096
	GROUND	BLUE
	+12V DC SUPPLY	BROWN
19	BATTERY SENSE	LINK
20	SATNAV PULSES	3m CABLE 135-0A-096
	SATNAV PULSE OUTPUT	BROWN
21	GROUND	BLUE

NETWORK TERMINATOR INSTALLATION

THE NETWORK TERMINATOR 239-10-056 IS A BLACK TWO WIRED COMPONENT WITH A RESISTANCE OF 100 OHMS. TWO ARE SUPPLIED WITH INSULATING SLEEVING TO PREVENT SHORTING OF THE WIRES.

IMPORTANT NOTE

A NETWORK TERMINATOR MUST BE FITTED ACROSS THE GREEN AND WHITE NETWORK DATA WIRES OF THE LAST UNIT OR JUNCTION BOX AT EACH END OF THE NETWORK CABLE. (SEE EXAMPLES BELOW)

WHEN ADDING MORE DISPLAYS OR UNITS TO THE NETWORK, ENSURE THAT THE TERMINATOR IS MOVED TO THE ENDS OF THE NETWORK CABLE. NEVER FIT MORE THAN TWO TERMINATORS ON THE NETWORK.

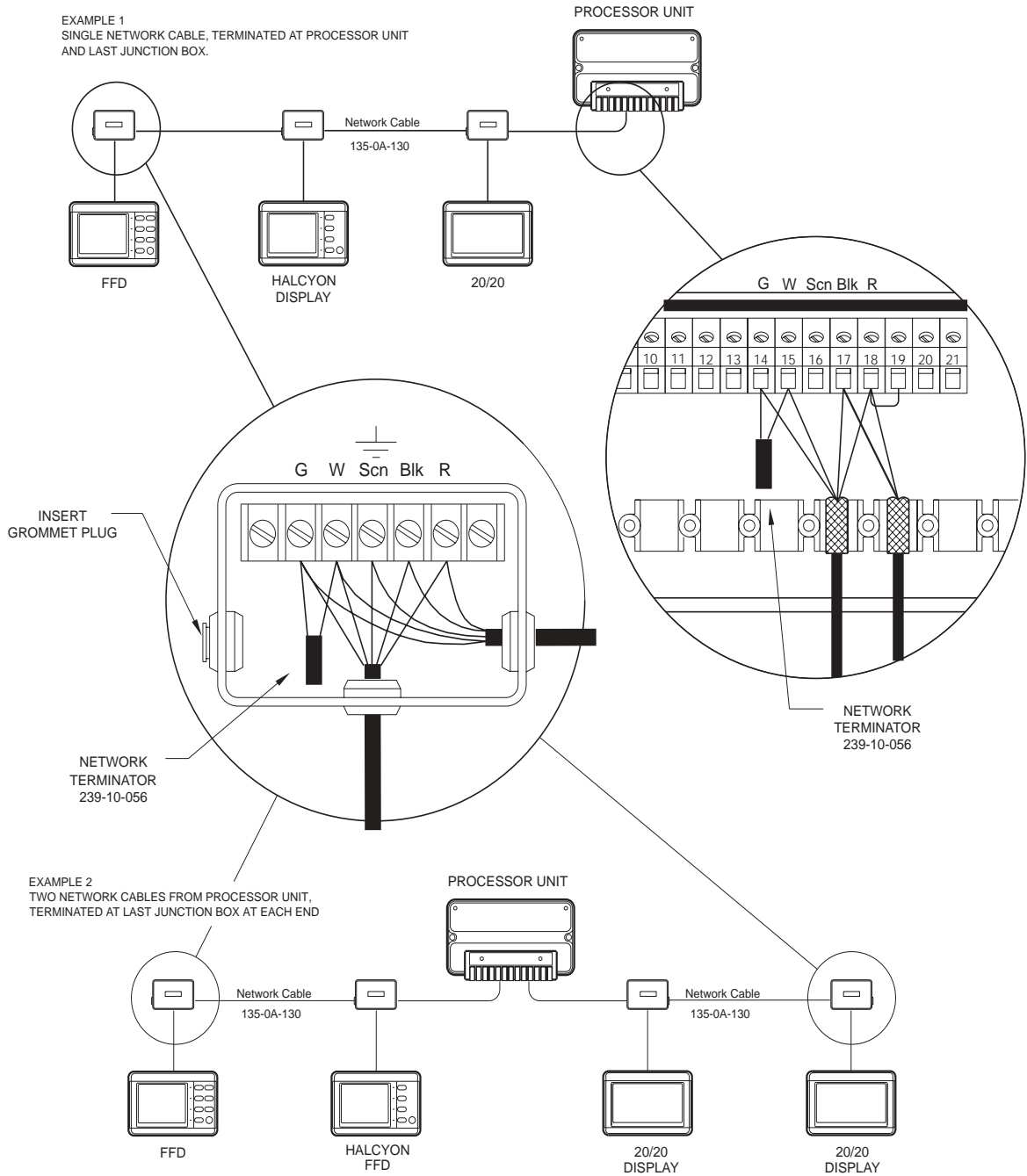

UNITS AND DISPLAYS MAY BE FITTED IN ANY ORDER ON THE NETWORK

213 MASTHEAD UNIT ELECTRICAL INSTALLATION SHEET

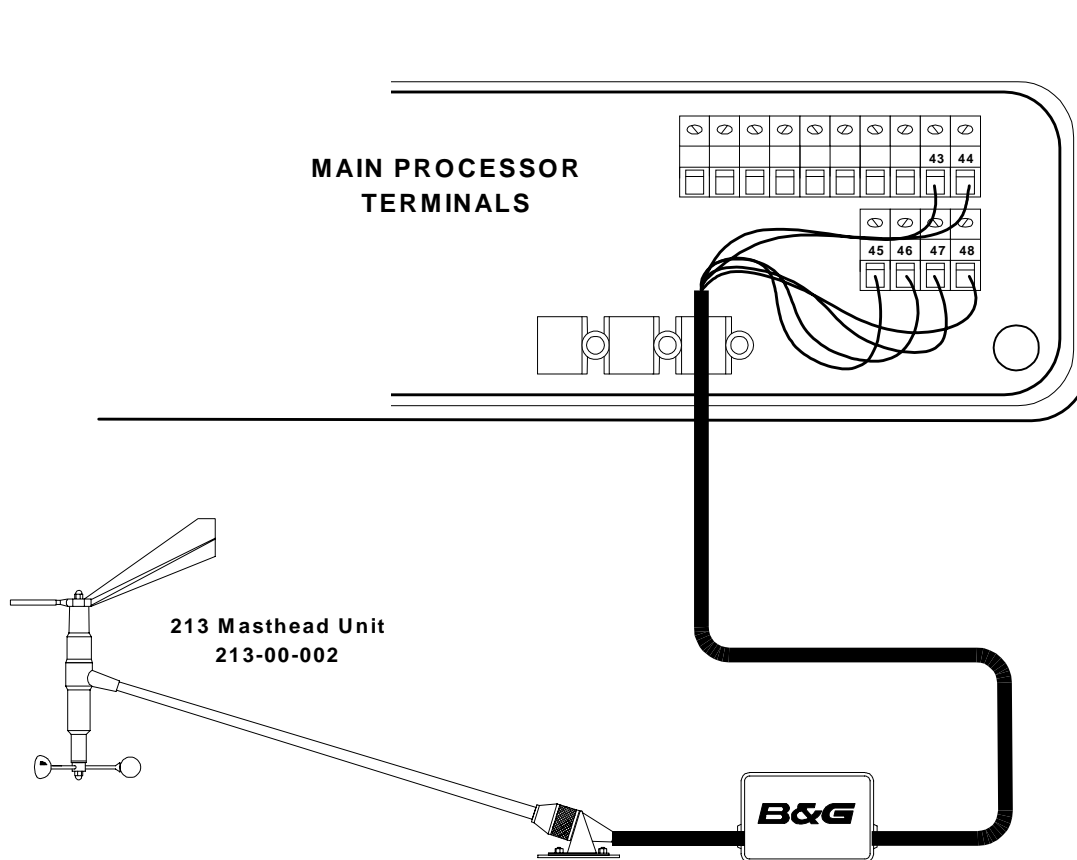

TERMINAL	FUNCTION	WIRE COLOUR
43	MHU SUPPLY	ORANGE
44	WIND SPEED INPUT	VIOLET
45	MHU GROUND	BLACK
46	WIND ANGLE BLUE	BLUE
47	WIND ANGLE GREEN	GREEN
48	WIND ANGLE RED	RED

TWIN XTL FINS GRAVITY SWITCH INSTALLATION

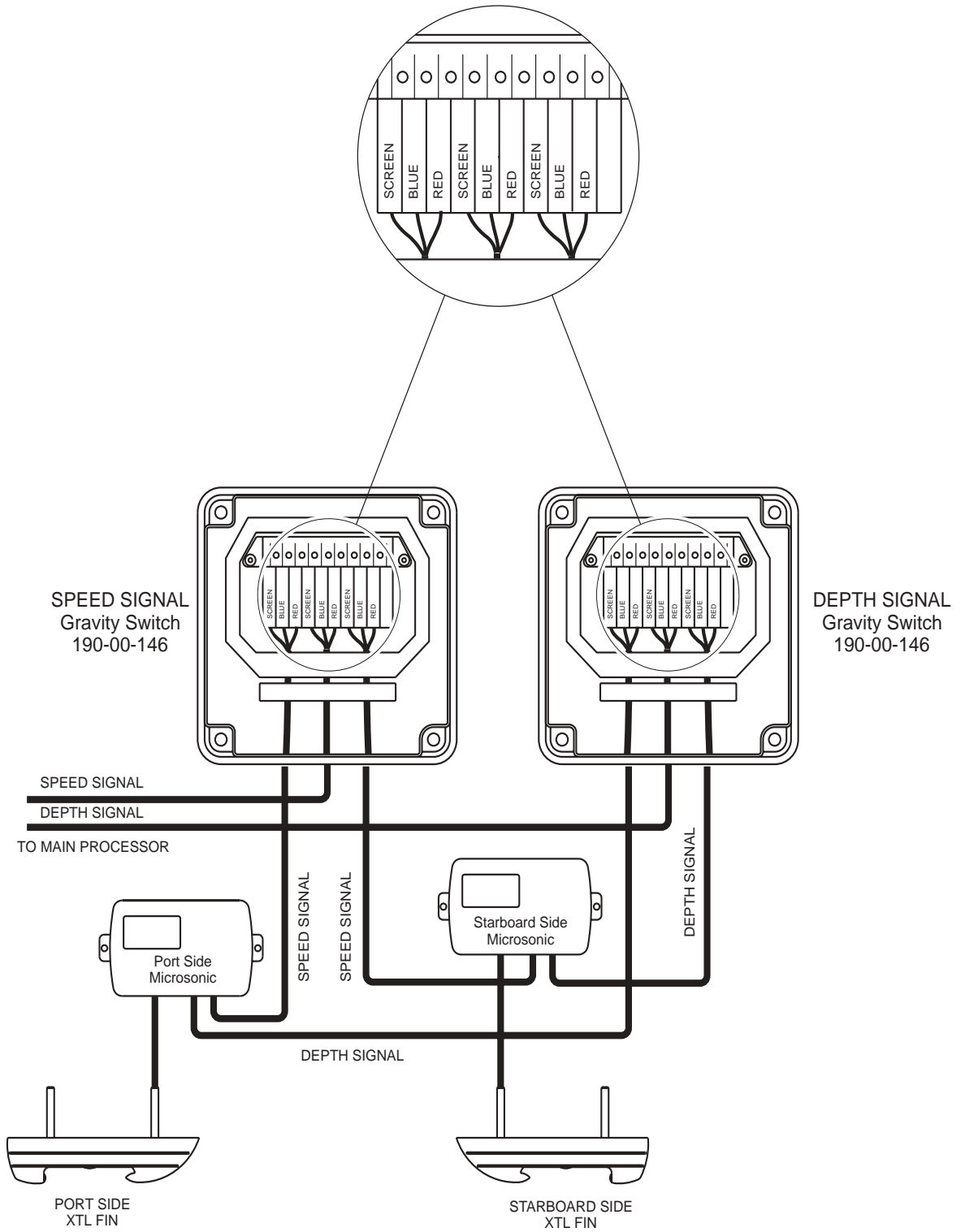

PADDLEWHEEL/ SONIC
CHANGE-OVER SWITCH INSTALLATION SHEET

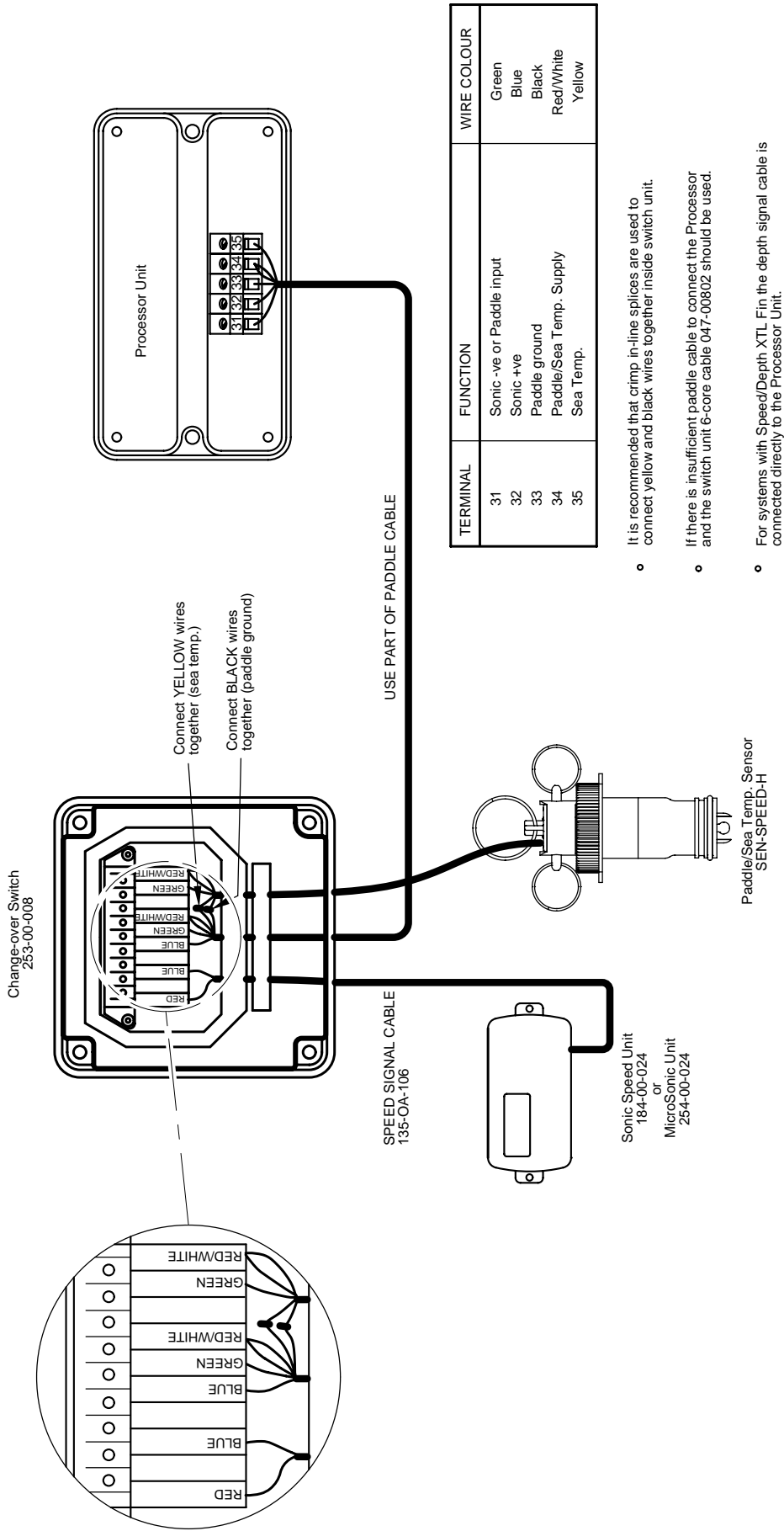

HYDRA 2000 SYSTEM EXAMPLE
INSTALLATION REFERENCE SHEET

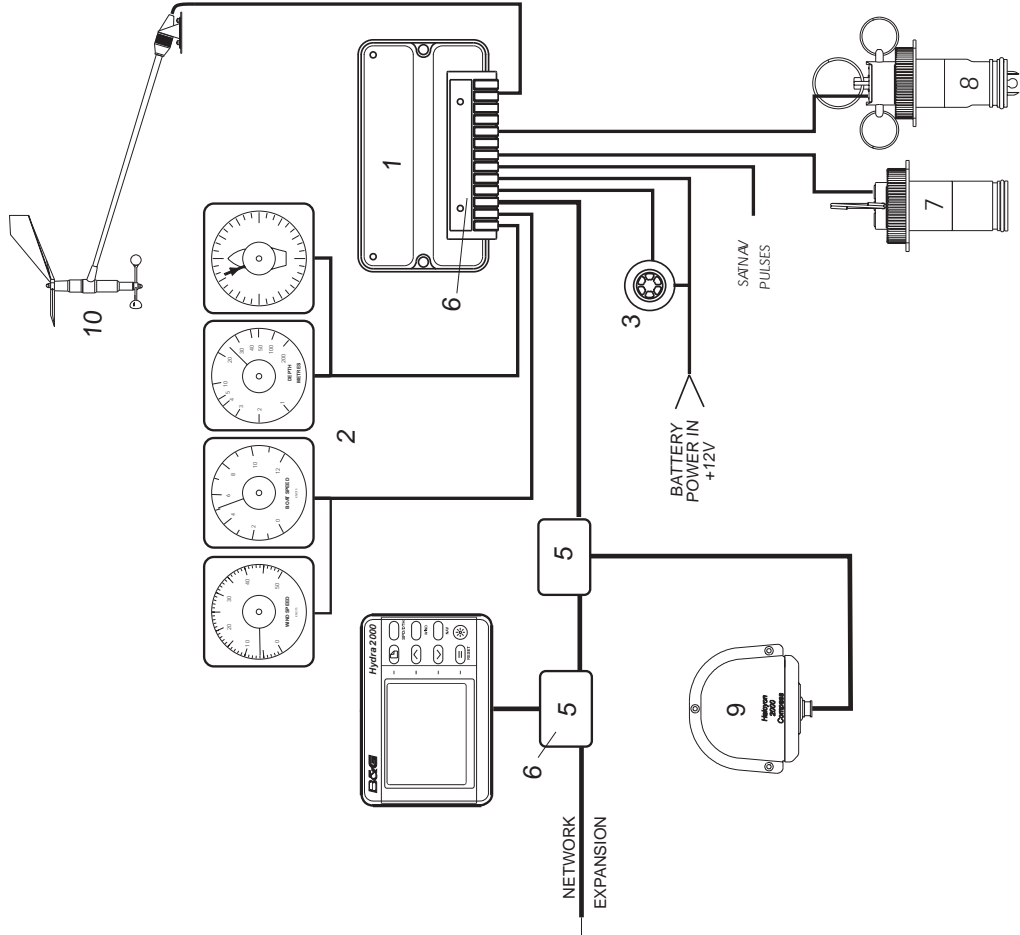

ITEM	UNIT	B&G PART NUMBER
1	MAIN PROCESSOR UNIT	330-00-005
2	ANALOGUE INDICATORS Meter 1 Meter 2 Meter 3 Meter 4	215-HL-016 215-HL-025 215-HL-019 215-HL-022
3	ALARM UNIT	130-00-045
4	NMEA FFD Bezel	240-00-028 240-00-035
5	JUNCTION BOX	288-00-001
6	NETWORK TERMINATOR	238-10-056
7	DEPTH TRANSDUCER	SEN-DEPTH-H
8	YACHT PADDLE	SEN-SPEED-H
9	HALCYON 2000 COMPASS	486-00-009
10	213 MASTHEAD UNIT	213-00-002

OPTIONAL UNITS (NOT SHOWN)	B&G PART NUMBER
ANALOGUE EXPANSION UNIT	340-00-009
STANDARD FFD BEZEL	240-00-026 240-00-035
HALCYON DISPLAY BEZEL	240-00-031 240-00-045
20/20 DISPLAY BEZEL	332-00-004 332-00-005 302-00-007
REMOTE CONTROLLER	184-00-024
SONIC SPEED UNIT	184-00-081
FWD SONIC TRANSDUCER	184-00-081
AFT SONIC TRANSDUCER	184-00-081
SEA TEMP SENSOR	224-00-065
UNDERWATER UNIT AND IMPELLER	117-00-120
GRAVITY CHANGEOVER SWITCH	190-00-146
CLINOMETER (HEEL/TRIM) BAROMETRIC SENSOR	690-00-004 690-00-007
MAST ANGLE ROTATION RUDDER/TRIM TAB ANGLE AIR TEMPERATURE SENSOR	RRF - ACP RRF - ACP 224-00-066
GPS SYSTEM	NET-GPDU-SY

DEPTH AND PADDLE
 ELECTRICAL INSTALLATION SHEET

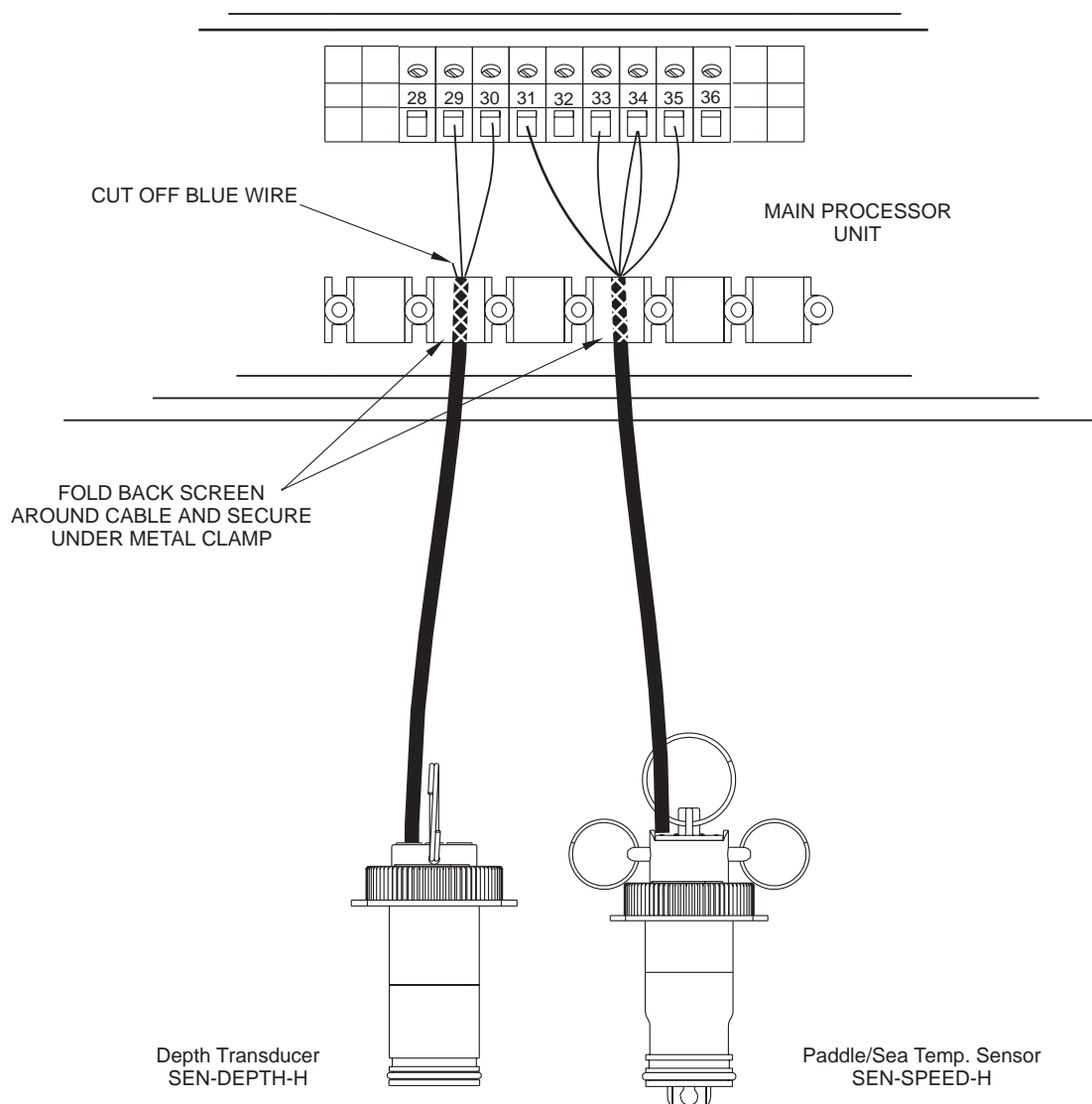

TERMINAL	FUNCTION	CABLE WIRE COLOUR
	DEPTH TRANSDUCER	16m CABLE ATTACHED
29	DEPTH -	BLACK
30	DEPTH +	BLUE
	PADDLE/SEA TEMP. SENSOR	16m CABLE ATTACHED
31	PADDLE INPUT	GREEN
32	NO CONNECTION	
33	GROUND	BLACK
34	SEA TEMP./PADDLE SUPPLY	RED AND WHITE
35	SEA TEMP. INPUT	YELLOW

2000 PERFORMANCE PROCESSOR INSTALLATION SHEET

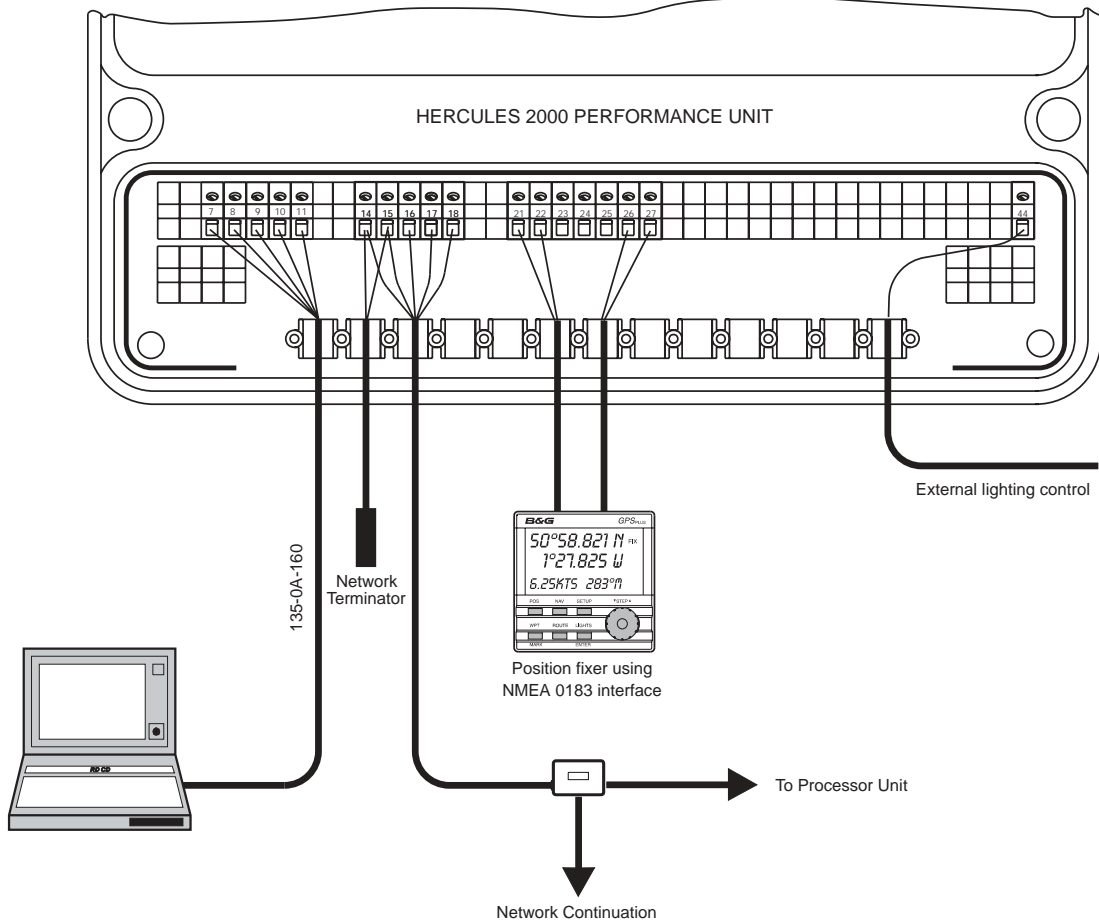

- NOTES: 1. A Network Terminator 239-10-056 must be installed across the Green and White wires of the last Unit or Network junction box.
2. Any compatible NMEA Position Fixer may be connected.

Terminal	Function	Wire Colour		Cable
7	RS232 CTS	Green		135-0A-133 25 way D - Type Socket Fitted or 135-0A-160 9 way D- Type
8	RS232 RTS	Violet		
9	RS232 Rx	Red		
10	RS232 Tx	Blue		
11	RS232 Ground	Black		
14	Network data -	Green		135-0A-130 4 cores/screen
15	Network data +	White		
16	No Connection	No Connection		
17	Supply ground	Black		
18	Supply +ve (12V nom.)	Red		
		NMEA 1	NMEA 2	
21	NMEA ground	Blue	Blue	Use 135-0B-098 2 cores/screen for each pair of NMEA signals 4 cables total
22	NMEA output 1	Red		
23	NMEA output 2		Red	
24	NMEA input 2 return		Blue	
25	NMEA input 2 signal		Red	
26	NMEA input 1 return	Blue		
27	NMEA input 1 signal	Red		
44	Lighting control input	Red		

CLINOMETER AND BAROMETRIC PRESSURE SENSOR INSTALLATION SHEET

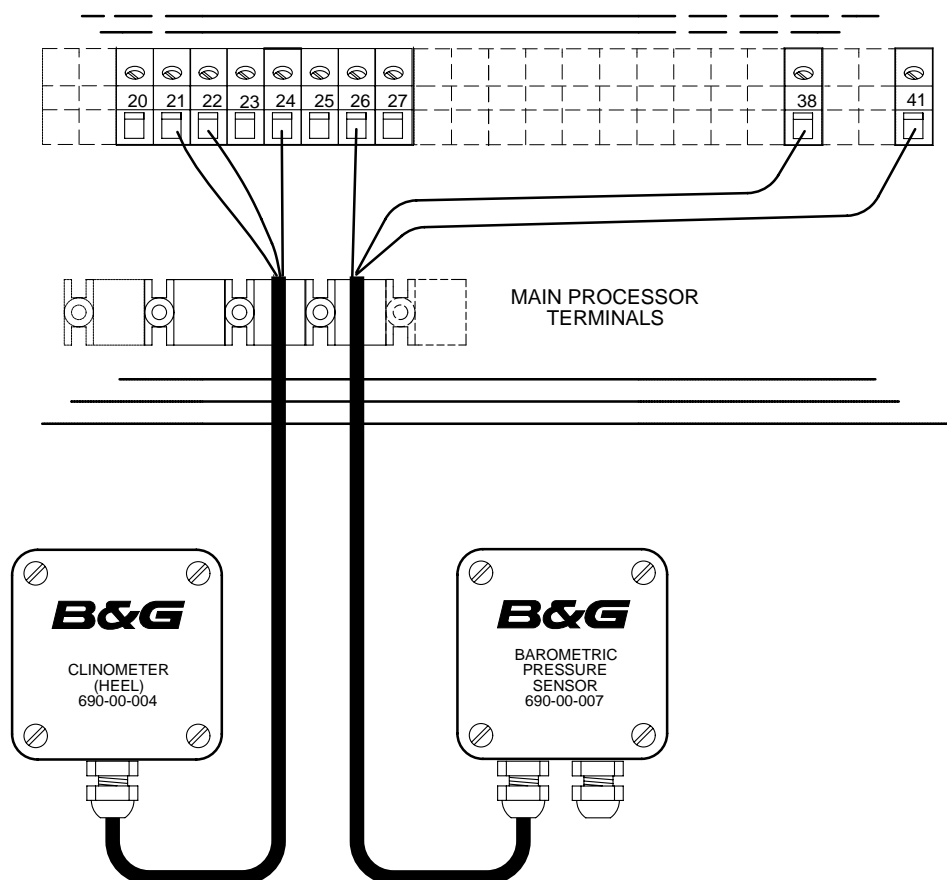

TERMINAL	FUNCTION	CABLE & WIRE COLOUR
	CLINOMETER SENSOR	CABLE ATTACHED
21	GROUND	BLUE
22	SENSOR SUPPLY 6.5V DC	RED
23	AIR TEMP. INPUT	
24	LINEAR 1 INPUT (HEEL)	GREEN
25	LINEAR 2 INPUT (TRIM)	
	PRESSURE SENSOR	CABLE ATTACHED
26	LINEAR 3 INPUT (BARO)	GREEN
27	LINEAR 4 INPUT (SPARE)	
38	BARO. SENSOR GROUND	BLUE
41	BARO. SENSOR SUPPLY	RED

CLINOMETER INSTALLATION

- Ensure the boat is level and steady, a sheltered berth is required for best results.
- For HEEL angle sensor select a transverse vertical bulkhead.
- For TRIM angle sensor select a longitudinal vertical bulkhead.
- For correct indication of port or starboard heel angle, mount the unit so that the top surface is horizontal and level, with the lid of the unit (labelled) facing aft.
- Heel angle calibration should be carried out to ensure accuracy. Refer to Manual, Section 4.

BAROMETRIC PRESSURE SENSOR INSTALLATION

- Mount the unit on a suitable vertical bulkhead, in a dry location, protected from the direct influences of the elements ie. rain, salt spray and extremes of temperature.
- Do not mount the sensor in a sealed compartment.

8-BUTTON NMEA FULL FUNCTION
DISPLAY INSTALLATION SHEET

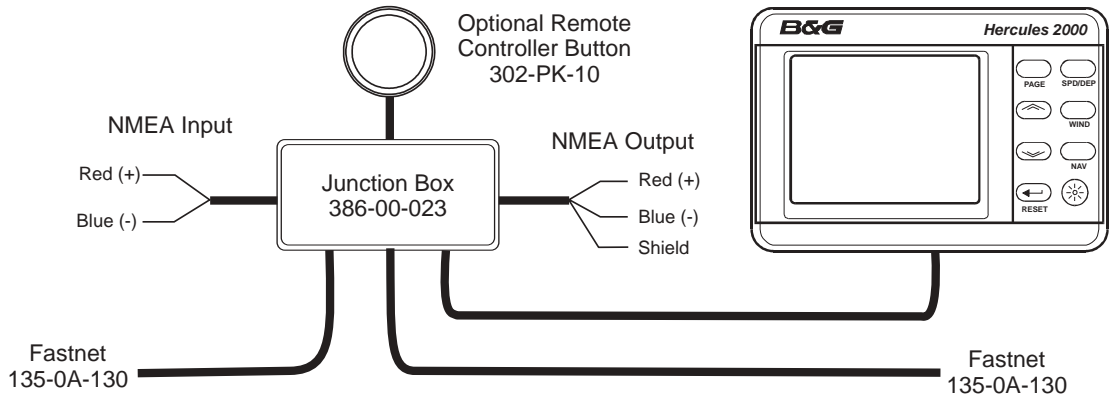

NMEA FFD CABLE FUNCTION	FFD CABLE COLOUR	SYSTEM NETWORK	NMEA INPUT	NMEA OUTPUT	REMOTE BUTTON
Network Data -ve	Green	Green			
Network Data +ve	White	White			
Network Cable Shield	Shield	Shield		Shield	
Ground	Black	Black		Blue	Blue
Supply +ve	Red	Red			
NMEA Input Signal	Brown		Red		
NMEA Input Return	Blue		Blue		
NMEA Output Signal	Violet			Red	
Remote Control Button	Yellow				Red

INSTALLATION NOTES

- An NMEA FFD can be connected at any point on the system network. Typically an NMEA FFD is mounted close to the NMEA device, e.g. at the chart table next to the GPS, thus minimising the NMEA cable routes.
- NMEA FFD's can be used in combination with all other display types, i.e. standard FFD's, Halcyon displays, 20/20 and Pilot displays.
- To prevent water intrusion into the display, do not cut the cable shorter than marked by the yellow band. If it is necessary to cut cables, then the wires **MUST** be tinned with a soldering iron to ensure a proper seal around the wires.

SCREENED CABLES

- Shielded NMEA cables are supplied to provide protection against unwanted emissions (EMC) and must be connected in accordance with these instructions.
- NMEA cable shields must be connected at the TRANSMITTING end.
- The NMEA output cable shield should be connected to the other cable shields in the junction box supplied.

NETWORK TERMINATION

- If the NMEA FFD is the last unit on the system network a network terminator **MUST** be fitted across the network data wires, i.e. between the green and white wires. Only two network terminators are required per system.

*8 BUTTON FULL FUNCTION
DISPLAY WIRING DETAILS*

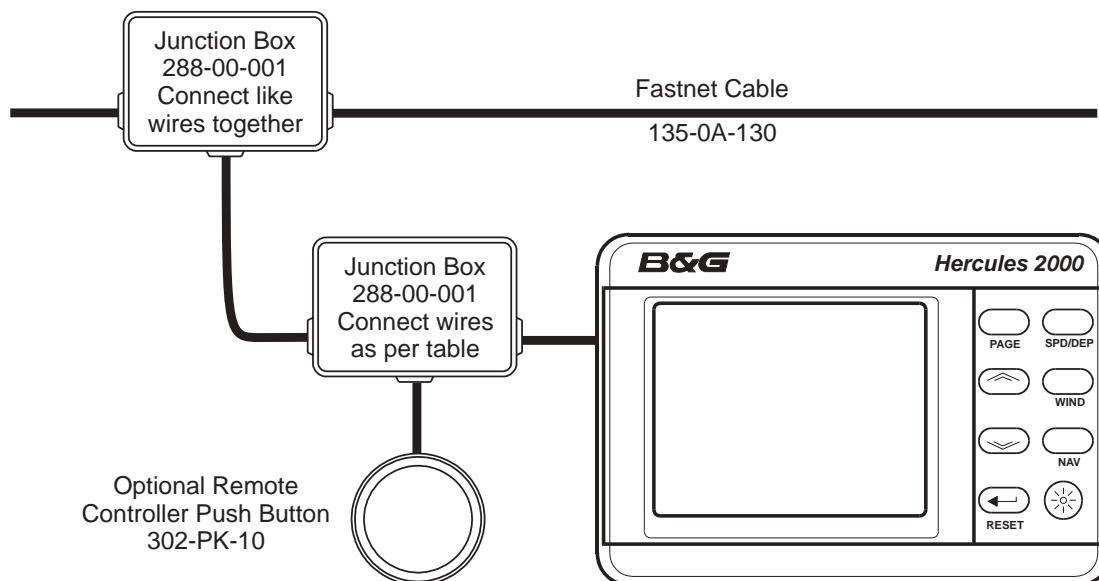

FFD CABLE FUNCTION	FFD CABLE COLOUR	SYSTEM NETWORK	REMOTE BUTTON
Network Data -ve	Green	Green	
Network Data +ve	White	White	
Network Cable Shield	Shield	Shield	
Ground	Black	Black	Blue
Supply +ve	Red	Red	
Remote Control Button	Yellow		Red
Not used	Brown		

INSTALLATION NOTES FOR HERCULES 2000

- The system requires at least one FFD.
- An FFD can be connected at any point on the system network.
- Multiple FFD's can be used on the system network. Each can control and enter data into the system processor memory.
- FFD's can be used in combination with all other display types i.e. NMEA FFD's, Halcyon displays, 20/20 and Pilot displays.
- To prevent water intrusion into the display, do not cut the cable shorter than marked by the yellow band. If it is necessary to cut cables, then the wires **MUST** be tinned with a soldering iron to ensure a proper seal around the wires.

SCREENED CABLES

- Shielded cables are supplied to provide protection against unwanted emissions (EMC) and must be connected in accordance with these instructions.

NETWORK TERMINATION

- If the FFD is the last unit on the system network a network terminator **MUST** be fitted across the network data wires, i.e. between the green and white wires.

Halcyon 2000 Connection Diagram

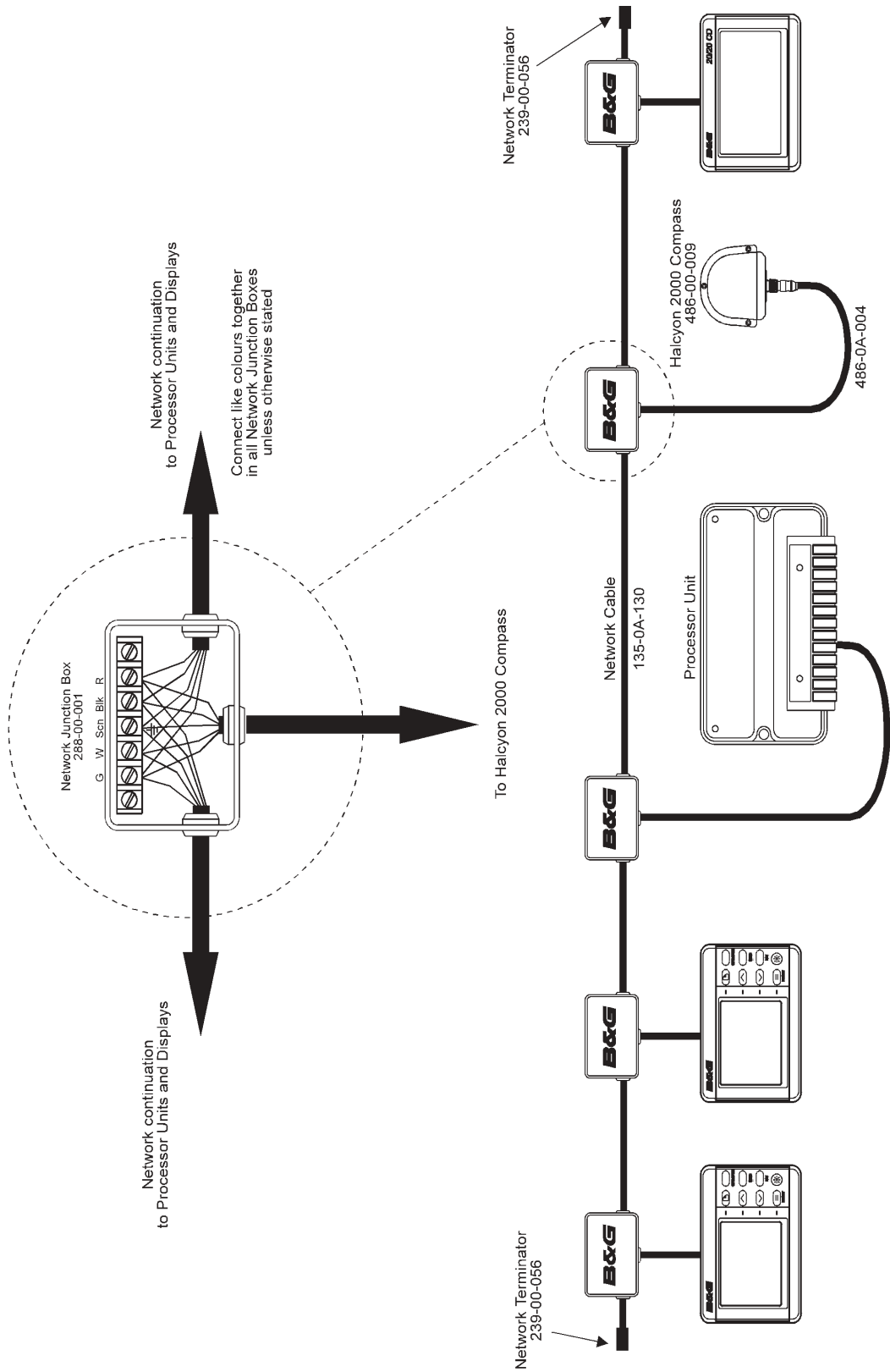

HALCYON GYRO PROCESSOR WITH HALCYON GYRO STABILISED COMPASS

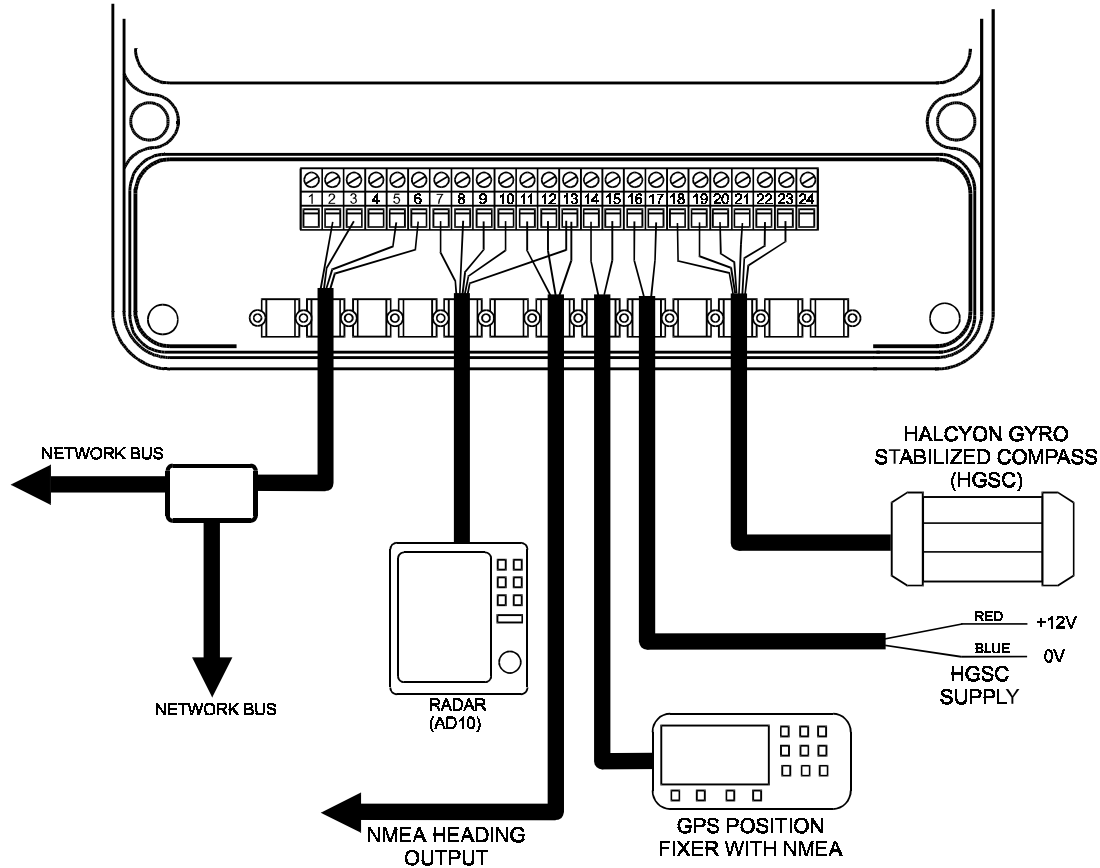

- Notes:**
1. All screened wires must have their screen attached to the clamp bar across the front case.
 2. The Halcyon Gyro Stabilised Compass (HGSC) has a separate supply and does not take power from the Network Bus. The HGSC sensor supply must be taken from a source rated at 2 amps.

Terminal	Function	Wire Colour	Cable
2	Network Data -	Green	135-0A-130 4 cores/screen
3	Network Data +	White	
5	Supply Ground	Black	
6	Supply +ve (12V nom.)	Red	
7	AD10 Clock Low (-)		
8	AD10 Clock High (+)		
9	AD10 Data Low (-)		
10	AD10 Data High (+)		
13	Ground		
11	NMEA Out - (V2.0)	Blue	135-0A-098 2 cores/screen
12	NMEA Out + (V1.5 & 2.0)	Red	
13	Ground	Blue	
14	NMEA In +	Red	135-0A-098 2 cores/screen
15	NMEA In -	Blue	
16	HGSC Power in +	Red	135-0A-098 2 cores/screen
17	HGSC Power in -	Blue	
18	HGSC Supply -	Black	BGH063001
19	HGSC Supply +	Red	
20	HGSC Data in +	White	
21	HGSC Data in -	Yellow	
22	HGSC Data out +	Green	
23	HGSC Data out -	Blue	

HALCYON GYRO PROCESSOR WITH NMEA GYRO INPUT

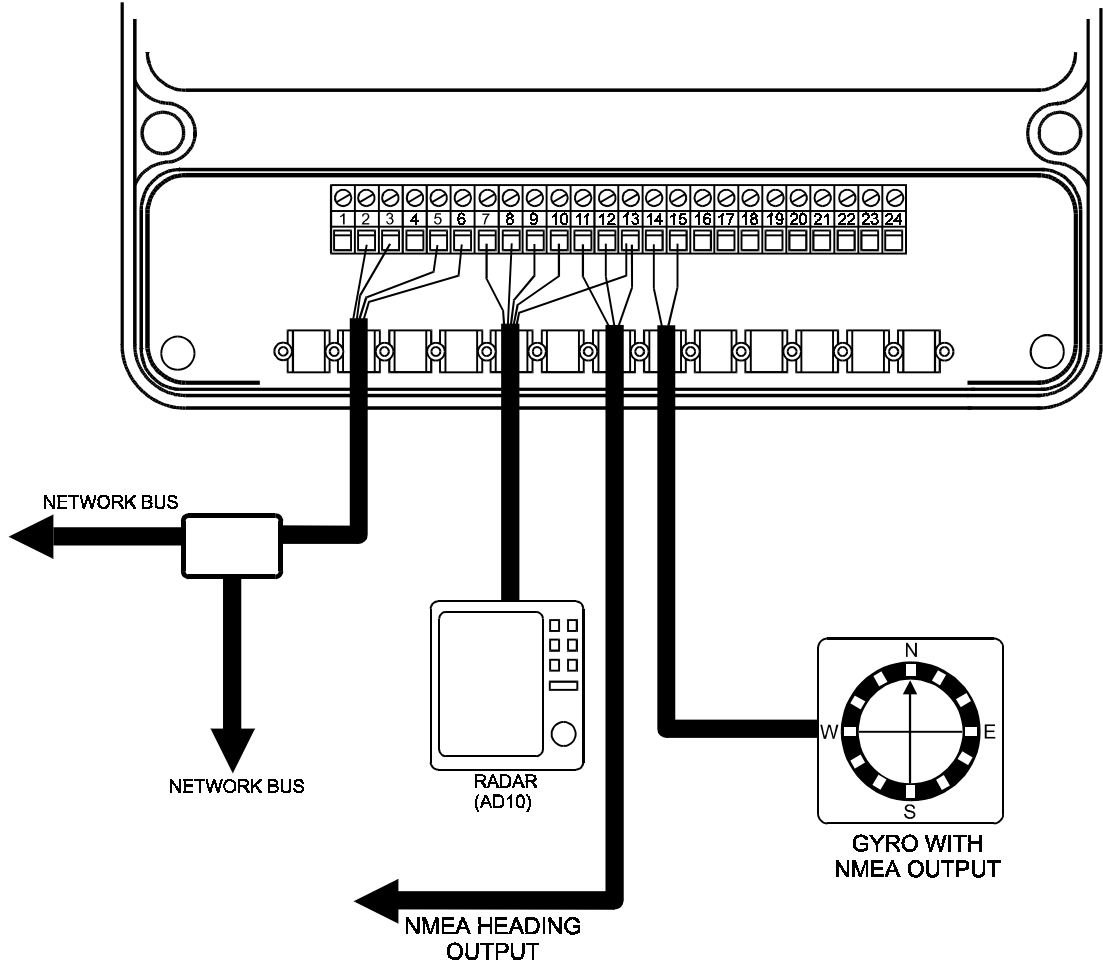

Notes: 1. All screened wires must have their screen attached to the clamp bar across the front case.

Terminal	Function	Wire Colour	Cable
2	Network Data -	Green	135-0A-130 4 cores/screen
3	Network Data +	White	
5	Supply Ground	Black	
6	Supply +ve (12V nom.)	Red	
7	AD10 Clock Low (-)		
8	AD10 Clock High (+)		
9	AD10 Data Low (-)		
10	AD10 Data High (+)		
13	Ground		
11	NMEA Out - (V2.0)	Blue	
12	NMEA Out + (V1.5 & 2.0)	Red	
13	Ground	Blue	135-0A-098 2 cores/screen
14	NMEA In +	Red	
15	NMEA In -	Blue	135-0A-098 2 cores/screen

HALCYON GYRO PROCESSOR AS OUTPUT INTERFACE

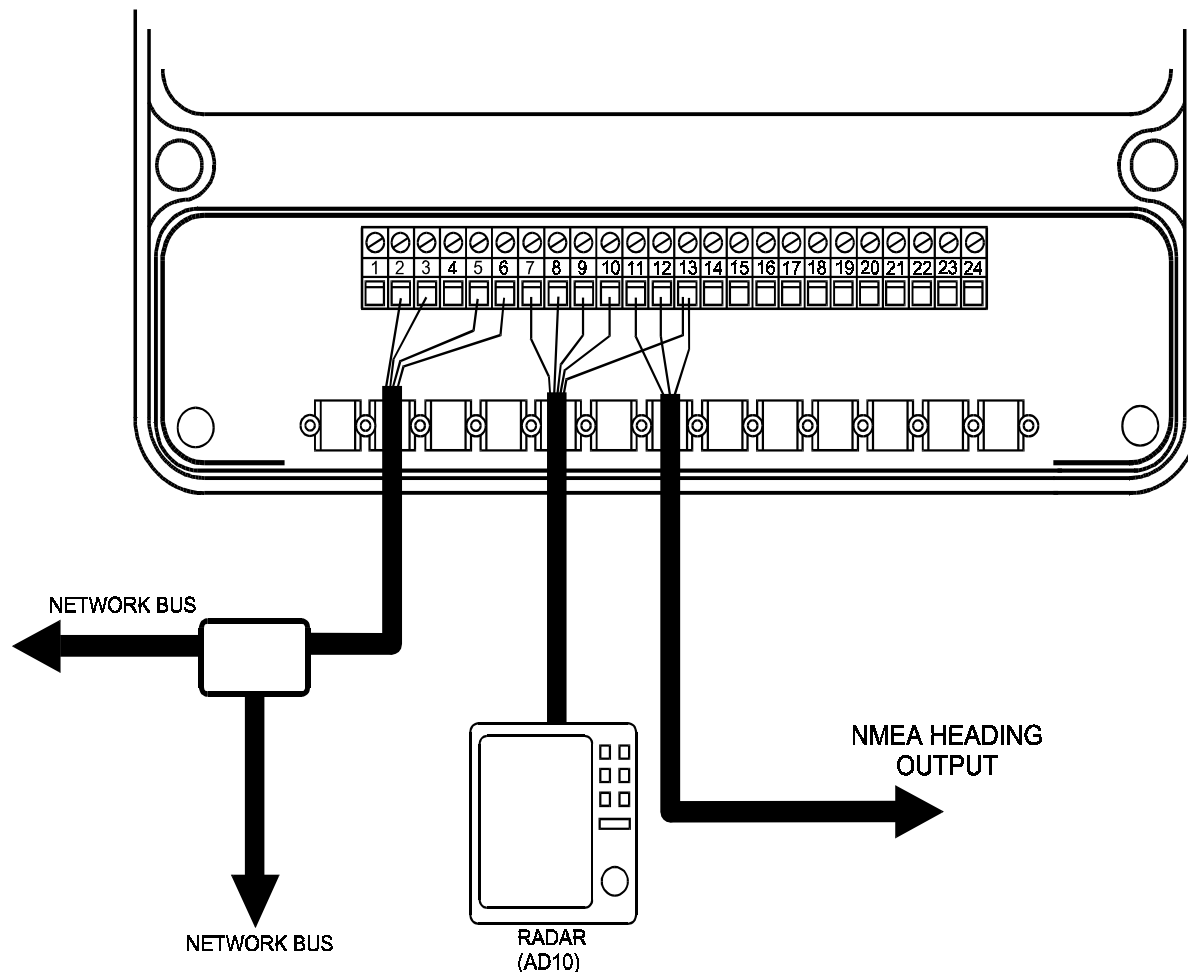

- Notes:
1. All screened wires must have their screen attached to the clamp bar across the front case.
 2. Heading source must be either a Halcyon 2000, B&G Pilot or 4 wire input to the Processor Unit (Super Halcyon 3).

Terminal	Function	Wire Colour	Cable
2	Network Data -	Green	135-0A-130 4 cores/screen
3	Network Data +	White	
5	Supply Ground	Black	
6	Supply +ve (12V nom.)	Red	
7	AD10 Clock Low (-)		
8	AD10 Clock High (+)		
9	AD10 Data Low (-)		
10	AD10 Data High (+)		
13	Ground		
11	NMEA Out - (V2.0)	Blue	135-0A-098 2 cores/screen
12	NMEA Out +(V1.5 & 2.0)	Red	
13	Ground	Blue	

ULTRASONIC SPEED SENSOR UNIT INSTALLATION SHEET

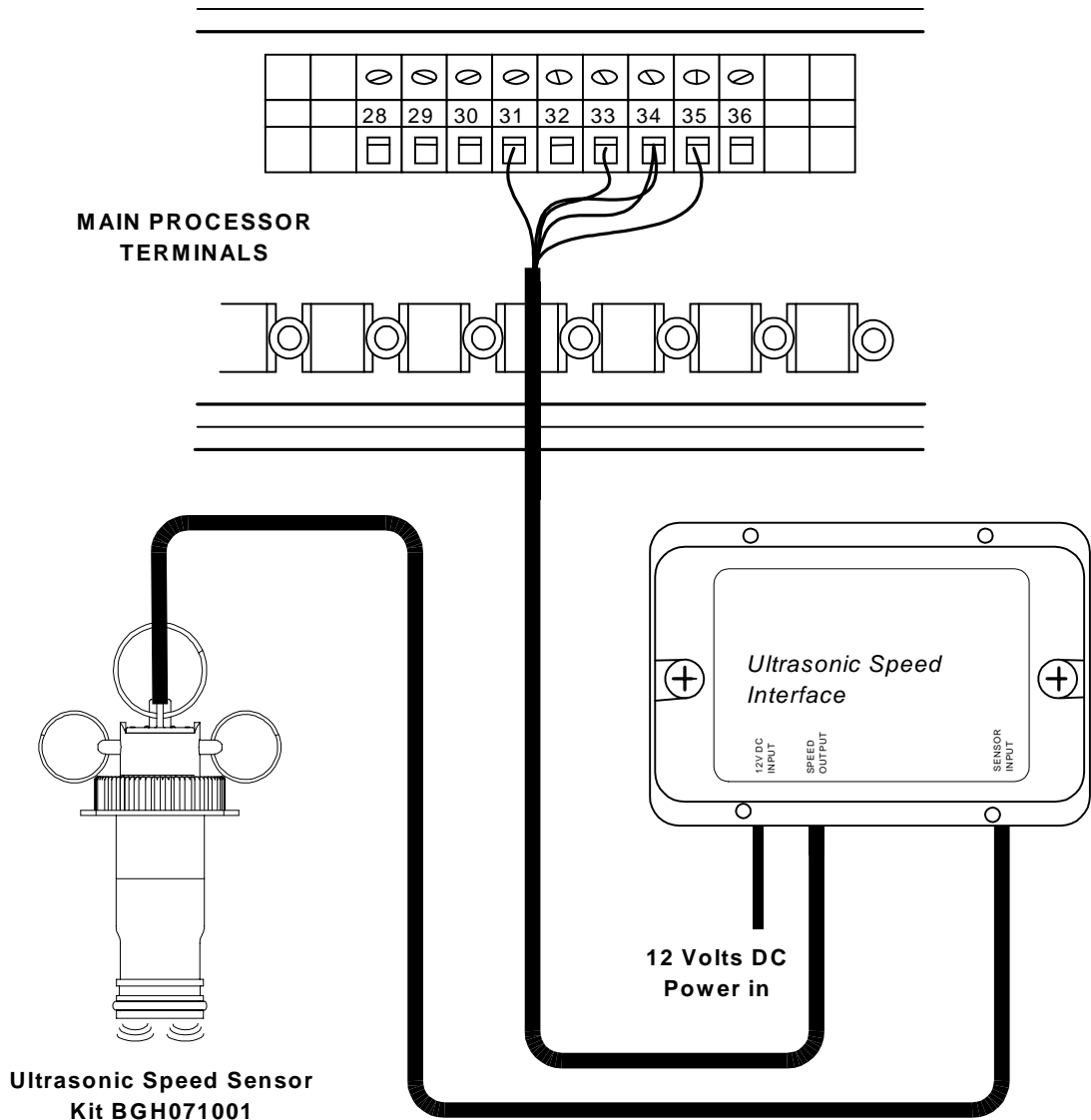

Notes: 1. All screened wires must have their screen attached to the clamp bar across the front case.

Terminal	Function	Wire Colour	Cable
31	Boatspeed Input	Green	135-0A-097 6 cores/screen
32	No Connection	-	
33	Ground	Black	
34	Sea Temperature/Paddle Supply	Red/White	
35	Sea Temperature Input	Yellow	

PART 5 - OPTIONS

CONTENTS

Para		Page
5.1	SYSTEM EXPANSION	5-3
5.2	SENSORS	5-3
5.2.1	Trim Angle Sensor	5-3
5.2.2	Mast Rotation Sensor	5-3
5.2.3	Heel Angle Sensor	5-3
5.2.4	Barometric Pressure Sensor	5-3
5.2.5	Rudder Angle Sensor	5-3
5.2.6	Sea Temperature Sensor	5-4
5.2.7	Air Temperature Sensor	5-4
5.2.8	Load Cells	5-4
5.2.9	Sensor Input Configuration	5-4
5.3	ANALOGUE INDICATORS	5-5
5.3.1	Options Available	5-5
5.3.2	Analogue Indicator Configuration	5-6
5.3.3	Meter Scaling	5-7
5.4	GRAVITY SWITCH	5-7
5.5	AUDIBLE ALARM	5-7
5.6	20/20 DISPLAY	5-8
5.6.1	The Display	5-8
5.6.2	Display Configuration	5-8
5.6.3	Function Selection - Remote Push-Button	5-9
5.6.4	Function Selection - FFD	5-9
5.6.5	Re-configuring 20/20 Display	5-10
5.7	40/40 DISPLAY	5-11
5.7.1	The Display	5-11
5.7.2	Display Configuration	5-11
5.7.3	Function Selection - Remote Push-Button	5-12
5.7.4	Function Selection - FFD	5-12
5.7.5	Re-configuring 40/40 Display	5-13
5.8	HALCYON 2000 COMPASS	5-14

CONTENTS (Contd.)

Para		Page
5.9	HALCYON DISPLAY	5-14
5.9.1	The Keys	5-15
5.9.2	Power/Lights Key	5-15
5.9.3	Page Key	5-15
5.9.4	Off Course Function	5-16
5.9.5	Stored Course Function	5-16
5.9.6	Head/Lift Trend Function	5-17
5.9.7	Set-up Port and Starboard References	5-18
5.9.8	Head Lift Trend - FFD	5-18
5.9.9	Head/Lift Trend - 20/20 Display	5-18
5.9.10	Turn Rate Function	5-18
5.10	EXPANSION PROCESSOR	5-19
5.10.1	The Expansion Processor	5-19
5.10.2	Linear Function Settings	5-20
5.10.3	Calibrating a Linear Channel	5-20
5.10.4	Expansion Processor Wiring	5-21

ILLUSTRATIONS

Fig No		Page
5.1	20/20 Display	5-8
5.2	40/40 Display	5-11
5.3	Halcyon Display	5-15

TABLE

Table No		Page
5.1	Analogue Indicators Available	5-5

PART 5 - OPTIONS

5.1 SYSTEM EXPANSION

The Hydra 2000 System may be expanded to provide a wider range of facilities and features by the addition of further displays, sensors, and interfaces. These Options are described in the following Paragraphs.

5.2 SENSORS

There are four linear inputs into the Main Processor which enable further sensors to be connected. In addition, with the addition of the Expansion Processor an extra 12 extra inputs are available.

5.2.1 Trim Angle Sensor

Provides display of Trim Angle and increases the accuracy of the following functions:

- Measured Wind Angle
- Measured Wind Speed
- True Wind Angle
- True Wind Speed
- True Wind Direction

5.2.2 Mast Rotation Sensor

This is essential if your mast rotates, otherwise the wind data will become inaccurate as the mast rotates away from the centerline. The addition of this unit gives two new functions, the Wind Angle to the Mast (W/A MAST) and Mast Angle (MAST ANG)

5.2.3 Heel Angle Sensor

Provides display of Trim Angle and increases the accuracy of the following functions:

- Measured Wind Angle
- Measured Wind Speed
- True Wind Angle
- True Wind Speed
- True Wind Direction
- Course
- Dead Reckoning
- Tidal Rate and Drift

5.2.4 Barometric Pressure Sensor

Measures the atmospheric pressure, allowing the Main Processor to record atmospheric pressure changes over varying periods of time.

5.2.5 Rudder Angle Sensor

The addition of a Rudder Angle sensor can be very useful, indicating how the boat is balanced.

5.2.6 Sea Temperature Sensor

Measures the sea water temperature.

5.2.7 Air Temperature Sensor

Measures local air temperature.

5.2.8 Load Cells

Up to 12 loadcells can be added to the Hercules 2000 system via the FastNet databus (refer to the B&G Loadcell Installation/Calibration Manual). If desired, the loadcells may be connected as non-networked devices and wired directly to the linear inputs of the Hercules Main Processor. These loadcells should provide a linear output voltage in the range of 0 to 6.5 volts.

5.2.9 Sensor Input Configuration

Additional sensors can be added to the system by connecting to one of the four linear inputs on the Main Processor, Linear channels 5 to 16 are available with the addition of an Expansion Processor. These can be configured to take different sensors. If you connect the sensor to the linear input that B&G have anticipated then you need take no action beyond the connection itself, since the default linear input configuration will be the right one. The default settings for the four inputs on the Main Processor are as follows:

- Linear 1 = Heel Angle
- Linear 2 = Trim Angle
- Linear 3 = Barometric Pressure
- Linear 4 = 0 to 1000 format

Should you wish to connect one of the other sensors, then you will have to reconfigure the linear channel that you are connecting it to. This is done by following the menu path:

MISC → LINEAR X, **CALBRATE** → **CAL VAL1**

The number you enter to CAL VAL1 should correspond to the sensor you are connecting as follows:

- 1 = Normal Linear output 0-1000
- 2 = 152 Wind Speed (together with normal linear output 0 – 1000)
- 3 = Rotating Mast Correction (output Mast Angle and Wind Angle to Mast)
- 4 = Heel Angle
- 5 = Trim Angle
- 6 = Barometric Pressure and Pressure Trend
- 7 = Rudder Angle

Note

Do not select the same number on more than one linear input, otherwise the selection will be ignored (no function can be connected to more than one input except the Normal Linear input which is not limited).

5.3. ANALOGUE INDICATORS

5.3.1 Options Available

Type of Indicator	Scale	B&G Part Number
Boat Speed	0 to 12.5 knots	215-HL-019
Boat Speed	0 to 25 knots	215-HL-058
Boat Speed	0 to 50 knots	215-HL-154
Wind Speed	0 to 25 metres/second	215-HL-071
Wind Speed	0 to 50 knots	215-HL-022
Apparent Wind Angle	360° wind direction	215-HL-016
True Wind Angle	360° wind direction	215-HL-016
Magnified Wind Direction	40-0-40 degrees	215-HL-017
Head/Lift Trend*	40-0-40 degrees	215-HL-152
Depth	0 to 200 metres	215-HL-025
Depth	0 to 100 Ft/fathoms	215-HL-026
Compass Card	360°	215-HL-142

Table 5.1 - Analogue Indicators Available

Cross Track Error (XTE)	10-0-10 nautical miles	215-HL-119
Off Course*	40-0-40°	215-HL-151
Heel Angle	40-0-40°	215-HL-160
Rudder Angle	40-0-40°	215-HL-158

Table 5.1 - Analogue Indicators Available (cont.)

Up to four different types of analogue indicators, selected from the range listed in Table 5.1 can be added to the system. If more analogues are required then an Expansion Processor must be used, allowing another four indicators to be added to the system.

Note

Items marked with an asterisk are only available with the Halcyon Display.

5.3.2 Analogue Indicator Configuration

If meters other than the defaults are chosen then it is necessary to reconfigure the outputs. This is done from any FFD as follows:

- (1) Power up the system from any FFD while holding down the **Enter** Key, DIAGNOST appears.
- (2) Press **Scroll Up**, CNFG SYS appears, press **Enter** to select this option. Now press **Enter** again to select the METERS option.
- (3) With OPTIONS flashing, press **Enter**, METER 1 appears, the **Scroll Up** Key is now used to scroll through the meter outputs. (Refer to the installation sheet to determine the meter options and their respective meter drives).
- (4) With the appropriate meter output flashing in the top display, press **Enter** to reveal the current option assigned to that meter. Pressing **Scroll Up** at this stage, and then **Enter** again, will reveal the METER 2 option. Repeating this process will reveal the METER 3 and METER 4 options as required.
- (5) Press **Enter**, the lower text will flash. Use **Scroll Down** to scroll through the options until the appropriate one (e.g. DEPTH) is shown. Pressing **Enter** will select that option, and the meter output will be configured to drive a DEPTH meter.

(6) Press **Page** to return to normal operation.

Note

It is possible to configure more than one meter drive to the same meter option (e.g. BOAT SPD on METER 1 and METER 2).

5.3.3 Meter Scaling

Meter scaling can also be varied for boat speed and wind speed. For example if a 25 knot full scale Boat Speed Meter is required, this can be done as follows:

- (1) Follow steps (1) and (2) as detailed in Para 5.3.3.
- (2) With OPTIONS flashing, press **Scroll Up** to reveal SCALING and press **Enter**, BOAT SPD will appear. A further press of **Enter** will reveal the current maximum meter scale value for the Boat Speed Meter.
- (3) To change this (e.g. to 25 knots) press **Enter** and then **Scroll Up** to increase the number to 25.0. A final press of **Enter** will then enter the new maximum scale. The Boat Speed Meter will read between 0 and 25 knots.
- (4) Press **Page** to return to normal operation.

5.4 GRAVITY SWITCH

In installations where two speed sensors or depth transducers are fitted a gravity change over switch can be fitted to automatically select the leeward sensor. A switch on the outside of the unit overrides the automatic selection if required, for example when calibrating the individual speed sensors.

5.5 AUDIBLE ALARM

The Main Processor contains a relay switch for an external audible alarm if required.

5.6 20/20 DISPLAY

5.6.1 The Display

The 20/20 is a fully programmable, single function, large digit, display which may be installed anywhere in the yacht.



Fig 5.1 - 20/20 Display

5.6.2 Display Configuration

The 20/20 may be configured to display any function available on your Hydra 2000 System. It is however provided with 14 pre-set functions which may be selected by use of a Remote Button connected to the display or via any FFD on the system.

The pre-set functions are as follows:

Boat Speed	Depth m
Depth ft	Apparent Wind Speed
Apparent wind Angle	True Wind Speed
True Wind Angle	Velocity Made Good
True Wind Direction	Timer Count Up/Down
Compass heading	Course Over Ground*
Bearing to Waypoint*	Speed Over Ground*

Note

Functions marked with an * are NMEA Functions and are available only when a suitable Position Fixer is interfaced with the system.

5.6.3 Function Selection - Remote Push-Button

If a Remote Button is connected to a 20/20 Display any one of the 14 pre-set functions may be selected by pressing and holding down the associated Button. The Display will then cycle through the functions. When the required function is displayed, release the Button.

If the Button is held down too long and the required function is missed, press and hold down the Button again. The Display will then cycle through the functions in reverse order. When the required function is displayed, release the Button.

5.6.4 Function Selection - FFD

An alternative to using a dedicated Remote Push-button, is to control the 20/20 using any one of the standard FFDs on the system. Any 20/20 can be controlled from any FFD.

To change the function displayed on a 20/20 using a standard FFD, proceed as follows:

- (1) At the FFD, press and hold down the **Page** Key for at least 3 seconds. The FFD Display will change to show the function displayed on the 20/20 together with the display number. The selected Display will start to flash.
- (2) Using the **Scroll Down** Key cycle through the 20/20 numbers and select the required Display Number.
- (3) Using the **Scroll Up** Key cycle through the 14 pre-set functions until the required function is displayed on the FFD. Release the **Scroll Up** Key.
- (4) If the function is missed, press and hold down the **Scroll Up** Key and the functions will cycle through in reverse order. Release the **Scroll Up** Key when the required function is displayed.
- (5) Press the **Page** Key. The FFD will now return to normal operation and the 20/20 will display the selected function.

5.6.5 Re-configuring 20/20 Display

In addition to the 14 pre-set functions, any one of the 20/20 Displays may be re-configured to show any other function available to the system. This feature allows any 20/20 to be set-up to show the information most useful to the user at that station in the yacht.

The procedure for re-configuring a 20/20 function is as follows:

- (1) At the FFD, press and hold down the **Page** Key for at least 3 seconds. The FFD will change to show the function displayed on the 20/20 together with the display number.
- (2) Using the **Scroll Down** Key, cycle through the 20/20 numbers and select the one required.
- (3) Using the **Scroll Up** Key select the function you wish to change.
- (4) Press the **Enter** Key and the function currently being displayed on the 20/20 will start to flash.
- (5) Press and hold down the **Scroll Up** Key and cycle through the normal FFD Menu until the required function choice is displayed (e.g. NAVIGATE).
- (6) Press and hold down the **Scroll Down** Key until the required operational choice is displayed (e.g. COURSE).
- (7) Press the **Enter** Key to accept the selection.
- (8) Press the **Page** Key and the FFD will return to normal operation and the 20/20 displays the newly configured page.

Note

Latitude and Longitude are not available on a 20/20 Display.

5.7 40/40 DISPLAY

5.7.1 The Display

The 40/40 is a fully programmable, single function, large digit, display which may be installed virtually anywhere in the yacht.



Fig 5.3 - 40/40 Display

5.7.2 Display Configuration

The 40/40 may be configured to repeat any function (except latitude/longitude) available on your Hercules 2000 System. It is however provided with 14 pre-set functions that may be selected by use of a remote push-button connected to the display or via any FFD on the system.

The pre-set functions are as follows:

Boat Speed	Depth m
Depth ft	Apparent Wind Speed
Apparent wind Angle	True Wind Speed
True Wind Angle	Velocity Made Good
Compass heading	Timer Count Up/Down
Bearing to Waypoint*	Course Over Ground*
Speed Over Ground*	True Wind Direction

Note

Functions marked with an * are NMEA Functions and are available only when a suitable Position Fixer is interfaced with the system.

5.7.3 Function Selection - Remote Push-Button

If a remote push-button is connected to a 40/40 display any one of the 14 pre-set functions may be selected by pressing and holding down the associated button. The display will then cycle through the functions. When the required function is displayed, release the button.

If the button is held down too long and the required function is missed, press and hold down the button again. The display will then cycle through the functions in reverse order. When the required function is displayed, release the button.

5.7.4 Function Selection - FFD

An alternative to using a dedicated remote push-button, is to control the 40/40 using any one of the standard FFDs on the system. Any 40/40 can be controlled from any FFD.

To change the function shown on a 40/40 using an FFD, proceed as follows:

- (1) At the FFD, press and hold down the **Page** Key for at least 3 seconds. The FFD display will change to show the function displayed on the 40/40 together with the display number. The selected display will start to flash.
- (2) Using the **Scroll Down** Key cycle through the 40/40 numbers and select the required display number.
- (3) Using the **Scroll Up** Key cycle through the 14 pre-set functions until the required function is displayed on the FFD. Release the **Scroll Up** Key.
- (4) If the function is missed, press and hold down the **Scroll Up** Key and the functions will cycle through in reverse order. Release the **Scroll Up** Key when the required function is displayed.
- (5) Press the **Page** Key. The FFD will now return to normal operation and the 40/40 will display the selected function.

5.7.5 Re-configuring the 40/40 Display

In addition to the 14 pre-set functions, any 40/40 pre-set function may be re-configured to show any other function available to the system. This feature allows any 40/40 to be set-up to show the information most useful to the user at that station in the yacht.

The procedure for re-configuring a 40/40 function is as follows:

- (1) At the FFD, press and hold down the **Page** Key for at least 3 seconds. The FFD will change to show the function displayed on the 40/40 together with the display number.
- (2) Using the **Scroll Down** Key, cycle through each 40/40 display in turn (display flashes) and stop at your desired choice.
- (3) Using the **Scroll Up** Key select the function you wish to change.
- (4) Press the **Enter** Key and the function currently being displayed on the 40/40 will start to flash.
- (5) Press and hold the **Scroll Up** Key and cycle through the normal FFD Menu until the required function choice is displayed (e.g. NAVIGATE).
- (6) Press and hold the **Scroll Down** Key until the required operational choice is displayed (e.g. COURSE).
- (7) Press the **Enter** Key to accept the selection.
- (8) Press the **Page** Key and the FFD will resume normal operation and the 40/40 displays the newly configured page.

5.8 HALCYON 2000 COMPASS

The Halcyon 2000 Compass is a high performance electronic transmitting compass connected to your Hydra 2000. Heading information may be selected for display on any of the FFDs or on a Halcyon Display. Moving card type analogue indicators are available as an option.

The Halcyon 2000 software allows the compass to compensate for the magnetic fields in the vessel that may cause deviation errors. These errors can be reduced significantly by following the Calibration procedure described in Part 3.

5.9 HALCYON DISPLAY

The Halcyon Display is a dedicated electronic compass display which may be connected to your Hydra 2000 System in a similar manner to an FFD. The display provides clear and accurate digital indication of compass heading information together with a bar graph indicating port and starboard off-course error relative to a set course. The display area is split into three. The three large digits in the upper left part always show compass heading.

A bar graph indicator, below the compass heading display, will show deviation from the set course as segments of bar graph to the left or right of the zero centreline. This provides an immediate indication of the vessel being off-course to port or starboard. This off course value is also shown numerically below this display.

Four rows of text are provided down the right-hand side of the display. Each row is associated with the adjacent key and indicates the selected operating function and the various settings.

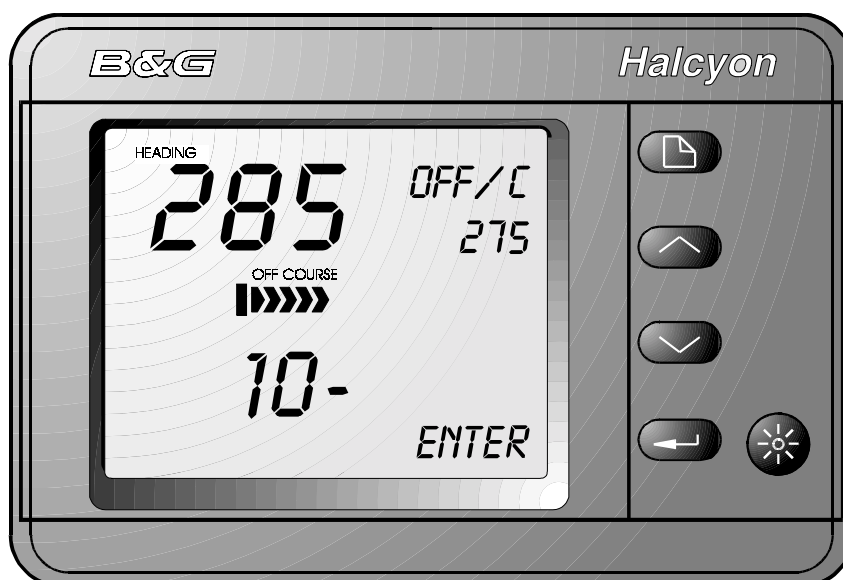

Fig 5.3 - Halcyon Display

5.9.1 The Keys

The Halcyon Display is provided with the following five keys:

- Power/Lights Key
- Page Key
- Scroll Up Key
- Scroll Down Key
- Enter Key

5.9.2 Power/Lights Key

The Power/Lights Key is operated in an identical manner to the Power/Lights Keys provided on the FFDs, see Part 2 - Operating Information.

5.9.3 Page Key

Successive pressing of the **Page** Key will access the following four functions in a fixed order:

Off Course	Stored Course
Head Lift Trend	Turn Rate

5.9.4 Off Course Function

The Off Course function provides the helmsman with accurate Off Course information to assist in steering a steady and accurate course.

Off Course is calculated by comparing the yacht's current heading with a previously set reference heading. The deviation is shown by the bar graph and numerically as degrees port or starboard.

The bar graph scale shows one segment for every 2° off course up to 10°, then one segment for every 5° up 20°. If the current heading is the same as the desired heading then only the central segment will be shown. The numeric display will show **00**.

The Off Course function may be reset by pressing the **Enter** Key, operation of a Remote Push-button if fitted or from any FFD. Pressing the **Enter** Key or Remote Push-button will select the current heading as the reference heading. Any deviation from this new course will be shown on the bar graph and the numerical display.

To reset the off course function from an FFD, select the NAVIGATE Menu and then OFF CRSE as described in Part 2 - Operating Information.

5.9.5 Stored Course Function

Up to 10 preset courses, numbered CRS 1 to CRS 10, may be stored at any one time. When the Stored Course function is selected by operation of the **Page** Key the display changes to show the selected course number with the value immediately below. All courses are retained in the Halcyon Display memory during power off so that the desired courses may be entered prior to departure.

To select a specific course number proceed as follows:

- (1) Select the Stored Course Function by successive presses of the **Page** Key until the display shows the Stored Course Function.
- (2) Press **Scroll Up** and CRS 1 will flash.
- (3) Using the **Scroll Up** and/or **Scroll Down** Keys select the course (CRS) number required.
- (4) Press the **Enter** Key to enter the selected course as the reference.

To change the value of any stored course proceed as follows:

- (1) Select the Stored Course Function by successive presses of the **Page** Key until the display changes to show the Stored Course Function.
- (2) Press the **Scroll Down** Key and the stored value of the course selected will flash.
- (3) Using the **Scroll Up** and **Scroll Down** Keys change the value to the new course.
- (4) Press the **Enter** Key to enter the new course.

5.9.6 Head/Lift Trend Function

This function is particularly useful to racing yachtsmen when sailing upwind. A port and starboard reference course can be set-up for each tack with reference to the current mean wind direction. They are then used to calculate whether the vessel is being 'lifted' or 'headed' and by how much. This is displayed graphically as well as numerically together with the legends LIFT or HEAD which indicate if the heading is above or below the reference course on the present tack.

Under steady conditions it should only be necessary to set-up this function once, preferably prior to the start of a race. If, however significant wind shifts occur it will be necessary to reset the port and starboard references.

A key benefit of this feature is that each time a tack is made or when rounding a leeward mark onto the wind again, there is an instant indication as to the current wind trend.

Note

The reference heading for a particular tack may be reset any number of times. For example if there is a long upwind leg, resetting the reference at the start of the leg will then give the head and lift trends from that point onwards.

5.9.7 Set-up Port and Starboard References

In this application the Halcyon Display will always know whether the current tack is port or starboard since it is linked to your Hydra 2000 System. PORT or STARB will be indicated on the display.

To set-up the port reference, sail the vessel on port tack until the current heading is giving the optimum upwind performance relevant to the current mean wind angle. Press the **Enter** Key (or Remote Button if fitted) and the port reference is now set.

To set-up the starboard reference repeat the above procedure on the starboard tack.

5.9.8 Head/Lift Trend - FFD

The Head/Lift trend indication can be shown on any FFD in a similar manner to Off Course information.

This function can be found on any FFD in the WIND Menu under LFT/HDR. It may be selected for display in the normal way and configured for any FFD pages as required, see Part 2 - Operating Information.

The Head/Lift Trend may be reset for the current tack by selecting CONTROL on the LIFT/HDR function and then RESET. This will reset the trend on all displays and, if fitted, the analogue indicator.

Note

If the Halcyon Display is not in the Head/Lift Mode, then Head/Lift trend will indicate OFF.

5.9.9 Head/Lift Trend - 20/20 Display

Head/Lift Trend information may be displayed on any 20/20 Display, see Para 5.7. An L or an H will be displayed adjacent to the digits to signify Lift or Head.

5.9.10 Turn Rate Function

The Turn Rate Function displays the vessel's rate of turn in degrees per second to port or starboard. There are two ways of displaying this information, either as Mean Rate of Turn or as Instantaneous Rate of Turn.

When the Turn Rate Function is selected by pressing the **Enter** Key, the display defaults to Mean Rate of Turn and MEAN is shown on the display.

When MEAN is selected, the present heading is compared with a continually updated mean heading and displayed graphically and numerically as degrees to port or starboard. This will give the trend to right or left of the average heading. Hence, if the heading fluctuates to port and starboard but with a bias to port, then the net trend to port will be displayed. Similarly for starboard.

The Instantaneous Rate of Turn is selected by pressing the **Scroll Down** Key when the Rate of Turn function is selected on the Halcyon Display. When this function is selected the display will change to show DEG/S indicating rate of turn in degrees per second. The centre bar graph will now show the instantaneous rate of turn to port or starboard with the numerical value displayed below.

Note

This is a useful feature when calibrating the Halcyon 2000 Compass where it is necessary to maintain a steady rate of turn.

5.10 EXPANSION PROCESSOR

5.10.1 The Expansion Processor

The Expansion Unit can be connected to the Hydra 2000 System via the Fastnet to drive four extra analogues (meters 5,6,7 and 8), and provide extra linear inputs.

A new menu automatically appears on all FFD's called EXPAND when an Expansion Processor is added to the system. Up to twelve linear functions may be displayed numbered LINEAR 5 to LINEAR 16. Initially only LINEAR 5 is shown. A linear function by default shows a number between 0, representing 0 volts on its input and 1000 representing 6.5 volts on its input. The voltage change is assumed to be linear in relationship. Hence an external sensor, for example a load cell giving a linear change in voltage as the load increases, may be connected to a linear input.

LINEAR 5 has four calibration values, other linear functions have three calibration values found by selecting CALBRATE on the appropriate linear function.

5.10.2 Linear Function Settings

Altering calibration value 1 (CAL VAL 1) allows the correct input sensor to be selected. The different inputs available are shown below:

1 or 2	normal linear input 0 to 1000
3	rotating mast correction for apparent wind angle
4	heel angle
5	trim angle
6	barometric pressure
7	rudder angle
8	air temperature

The default factory setting for a linear input is 1 (0-1000 format).

Note

Do not set different linear inputs to the same function (except 1 for normal linear input) or the calibration value will be ignored. This ensures that no function uses no more than one analogue input. However, any one of the Linear 1 to 4 inputs from the main processor may be set to the same function as any one of the Linear 5 to 16 inputs.

Calibration value 2 (CAL VAL 2) displays MIN VAL with a number that can be adjusted between -999 and 9999. This is the number to be displayed for a 0V input. The default setting is 000.

Calibration value 3 (CAL VAL 3) displays MAX VAL with a number that can be adjusted between -999 and 9999. This is the number to be displayed for 6.5V input. The default setting is 1000.

5.10.3 Calibrating a Linear Channel

Adjusting the MIN and MAX values allows the displayed value to be scaled to the appropriate range for the sensor attached. Taking a load cell for example, if the zero load output is 0V, MIN VAL=000 and if maximum load is 650 kgF at 6.5V then MAX VAL=650.

Calibration value 4 is only available on Linear 5 and this displays a value between 05 and 16. This setting determines the number of linear inputs that are available. For example, changing this value to 10 would display a maximum of 10 linear inputs. The default value is 05.

Damping is adjustable between 0 and 99 seconds. The default setting is 01.

Notes

1. When calibration value 1 is changed to select a desired input sensor, the linear value is no longer updated and a constant value is displayed until the page key is pressed.
2. Extra functions selected, and then removed, remain in the display menu but with no data shown until the system is switched off and then back on again.
3. Linear functions will always be shown if selected by CAL VAL 4 on linear 5. They will show no data if the CAL VAL 1 setting is configured to 1 or 2.

5.9.4 Expansion Processor Wiring

The Expansion Processor is connected to the system Fastnet databus for power and data requirements.

TERMINAL	FUNCTION	WIRE COLOUR
1	Meter 5 SIN	Green
2	Meter 5 COS	Blue
3	Meter 6 SIN	Red

TERMINAL	FUNCTION	WIRE COLOUR
4	Meter 6 COS	Violet
5	Meter 7 SIN	Red
6	Meter 7 COS	Violet
7	Meter 8 SIN	Green
8	Meter 8 COS	Blue
9	Meter Lighting	Yellow
10	Meter Common	Orange
11	Meter Ground	Black
12	N/C	
13	N/C	
14	Network Data -ve	Green
15	Network Data +ve	White
16	Network Screen	Screen
17	Battery Supply Ground	Black
18	Battery Supply 12V	Red
19	Battery Volts Sense	Link to 18
20	N/C	
21	Ground	Blue
22	Sensor Supply +6.5V	Red
23	Linear 5 Input	Green
24	Linear 6 Input	Green
25	Linear 7 Input	Green
26	Linear 8 Input	Green
27	Linear 9 Input	Green
28	N/C	
29	N/C	
30	N/C	
31	N/C	
32	N/C	
33	N/C	
34	N/C	
35	N/C	
36	N/C	
37	Linear 10 Input	Green
38	N/C	
39	Linear 11 Input	Green
40	Linear 12 Input	Green
41	+12V Switched Supply	Red
42	Linear 13 Input	Green

TERMINAL	FUNCTION	WIRE COLOUR
43	+6.5V Sensor Supply	Red
44	RPM Input	Green
45	Ground	Blue
46	Linear 14 Input	Green
47	Linear 15 Input	Green
48	Linear 16 Input	Green

PART 6 - DIAGNOSTIC DATA

CONTENTS

Para		Page
6.1	FFD DIAGNOSTICS	6-3
6.1.1	Diagnostic Function Selection	6-3
6.1.2	Key Test	6-4
6.1.3	Display	6-4
6.1.4	Network	6-4
6.1.5	RAM	6-4
6.1.6	PROM	6-5
6.1.7	EEPROM	6-5
6.1.8	Lighting	6-5
6.1.9	Debug	6-5
6.1.10	RES-SYS	6-5
6.1.11	Versions	6-6
6.1.12	Errors	6-6
6.1.13	Remote	6-6
6.2	MAIN PROCESSOR	6-7
6.2.1	Masthead Unit	6-7
6.3	DEPTH SOUNDER	6-8
6.3.1	Yacht Stationary	6-8
6.3.2	Yacht Moving	6-9
6.3.3	Consistently Shows Shallow Depth	6-10
6.3.4	Random Deep Depths	6-11
6.4	ERROR MESSAGES	6-12
6.4.1	Error Messages	6-12
6.5	HALCYON 2000 COMPASS	6-13
6.5.1	Shows Heading and CAL Flashing	6-13
6.5.2	Heading Shows ERR	6-13
6.5.3	Heading or COMP CAL Shows PHS	6-13
6.5.4	Two Headings Flashing Alternately	6-14
6.5.5	True Wind Direction, Tide Set or DR Course Not Functioning Correctly	6-14
6.6	NMEA Alphabetical Index Hydra 2000	6-15
6.6.1	NMEA Input Summary	6-15
6.6.2	NMEA Output Summary	6-16
6.6.3	NMEA Sentences	6-17

Intentionally Left Blank

PART 6 - DIAGNOSTIC DATA

6.1 FFD DIAGNOSTICS

The FFD contains a number of diagnostic functions. These allow the FFDs own keys, display and memory to be tested and also perform some checks on other parts of the system via the network. One of the more useful of these tests enables the user to determine the software version numbers of the Processor Units in the system. This information will often be useful when liaising with service agents.

6.1.1 Diagnostic Function Selection

To use the diagnostic functions they must be selected on the required FFD when the system is switched on as follows:

- (1) Power up the system by simultaneously pressing the **Power/Lights** and **Enter** Keys until DIAGNOST appears on the upper text in an otherwise blank display.
- (2) Press **Enter** and the first test option that appears is KEYTEST.
- (3) The required test can then be selected using the **Scroll Up** and **Scroll Down** Keys (see below for details of the tests).
- (4) Press **Enter** to start the test.
- (5) On completion of each test, press **Scroll Up** or **Scroll Down** to scroll to the next test. Press **Enter** to start the test.
- (6) To return the display back to normal operation press the **Page** Key.
- (7) Provided that the power is not switched OFF or a system reset performed, the diagnostics can be re-entered by holding **Enter** down and pressing the **Power/Lights** Key.

6.1.10 RES-SYS

CAUTION: Do not use this option during normal operation as all calibration values will be lost.
--

This allows individual units or the entire system to be reset. The network node address of the unit to be reset is selected using the **Scroll Up** and **Scroll Down** Keys and then the **Enter** key is pressed. The node allocations are as follows:

- 01 - Depth Board
- 05 - Wind Board
- 10 - Hatcyon 2000 Compass
- 11 to 12 (Typically 12) - Autopilot
- 0D - Expansion Board
- FF - Entire System

Note

When the system is reset all calibration, damping and alarm values will be set back to default settings, all log values and trip functions will be reset to zero. All display units will reset to their default page settings. After a delay of about 20 seconds the system should be switched OFF and then back ON twice to complete the reset procedure.

6.1.11 Versions

This option allows the user to obtain the software version numbers for the FFD (DISPLAY), Depth board (DEPTH), Wind board (WIND), Expansion Unit (EXP UNIT) and Pilot, if fitted. With 'VERSIONS' flashing on the display, press **Enter**. Then use the **Scroll Up** Key to select the option whose version number is required and press **Enter** to display the software checksum of the appropriate unit, in the bottom display. The last two digits of the checksum are the software version number.

6.1.12 Errors

This test is used chiefly to interrogate the Hydra 2000 network and is designed mainly for use by service technicians to ascertain levels of interference that may be present. For example interference may be induced by an SSB transmitter or radar. The display shows the number of messages that have not been transmitted correctly first time. Between 10 and 20 errors per minute is quite normal. A higher number of errors can also be an indication that the network terminators are not correctly fitted.

6.1.13 Remote

This facility allows the user to invoke internal RAM, PROM and basic network checks on any remote processor node on the network, and display the appropriate error messages on the FFD. Node numbers are allocated when the system is switched ON for the first time or after a system reset.

In the Hydra 2000 System the numbers will be:

Depth board	1
Wind board	5

In a system with additional processor nodes it may be necessary to determine the individual node numbers by disconnecting nodes in turn and running the remote PROM test. If no pass or fail message is displayed within 10 seconds then it can be assumed the node being tested is not in the system. The REMOTE tests for the currently selected node can be exited by holding **Enter** down and pressing the **Power/Lights** Key.

6.2 MAIN PROCESSOR

The main processor contains two circuit boards: the wind board and the depth board. The depth board is responsible for boat speed, sea temperature and depth measurement. The wind board is the main sensor responsible for wind functions and also drives the analogue meters. It has special inputs for the Masthead Unit, Super Halcyon compass, air temperature, battery voltage and four linear inputs that can be connected to a variety of other sensors (see Part 4 - Installation Instructions).

6.2.1 Masthead Unit

If there appears to be a problem with wind speed or wind angle first check the cable connections at the main processor and at the mast base junction box. The easiest way to test the MHU cable is by substituting a spare cable. If the cable is damaged in the mast the cause of the damage should be ascertained and the mast re-rigged or new conduit installed before replacing the cable. The Masthead Unit should always be removed before the mast is unstepped to avoid damage. It should be stored in its original packing box with the vane and cups removed.

Note

The Masthead Unit's bearings should not be oiled as they are of a sealed pre-lubricated type and additional oil may cause chemical breakdown of the existing lubricant.

6.3 DEPTH SOUNDER

Fault finding on the depth sounder is often difficult as depth sounder performance is dependent on many factors: transducer type and installation, boat speed, electrical noise, sea state, sea bed conditions, air and plankton in the water. Indications of problems with the depth sounder normally manifest themselves in one of three ways:

- (a) display shows (Floating Bars)



- (b) display locks down showing depths in the range 0 to 1.5m, or

- (c) display shows random deep depths

All of the above symptoms can be caused by external conditions so care and additional tests should be performed before concluding that the fault lies within the depth sounder. There are two values output by the depth sounder that can be of assistance in diagnosing problems, these are receiver gain and noise that can be found in the PARAMTR Menu on a FFD.

6.3.1 Yacht Stationary

Symptom: Display consistently shows (Floating Bars) when well within the range of the sounder with the yacht stationary in the water:



This is an indication that no consistent signal is being received by the depth sounder.

Possible Causes:

- (a) The transducer is not connected.
- (b) The transducer is not in its housing.
- (c) If sounding through the hull there is not enough oil in the housing or the hull material is not suitable to sound through.
- (d) The transducer is faulty or has been damaged. The transducer should be checked for any damage, barnacle growth or thick layers of paint. If it needs cleaning this should be done with a scrubbing brush. The face of the transducer may have a thin coat of anti-fouling applied to it making sure no air bubbles are trapped in the paint. The cable should be checked for damage. The resistance between the Blue and Black cores should be in the region of 0.5 to 5 Ohms and resistance between the screen and the cores should be infinity.

Resistance measurements should only be made with the transducer disconnected from the Processor Unit.

- (e) The gain of the receiver has been set too low. It is possible to adjust the maximum gain via CAL VAL1 on gain. This is normally set to 30 and should not be adjusted.

6.3.2 Yacht Moving

Symptom: Display shows (Floating Bars) when yacht is moving:



This is most often an indication of difficult sounding conditions, but can also indicate a badly positioned transducer.

Possible Causes:

- (a) Difficult sounding conditions and or depth sounder unable to track rapidly changing bottom. If coming into shallow water yacht should slow down and proceed with caution.

(b) Aeration in the water, most often caused by the wake of another vessel. This can persist in the water for a long period after the passing of the vessel. In some instances the depth sounder will indicate the depth of the aeration layer caused by a large vessel.

(c) Poorly sited transducer. Determine what conditions cause the problem by doing some manoeuvring trials in an area that has a relatively uniform depth, a solid bottom and is clear of the wake from other boats. First determine the maximum speed at which reliable soundings can be made when traveling in a straight line. Then repeat the tests when turning to port and starboard. If better results can be obtained when turning it is possible that there is something in front of the transducer causing aeration. This may be a hull fitting like a water outlet in which case the transducer or the hull fitting should be moved. If there seems little difference whether turning or not, the position of the transducer should be reviewed. It may be coming out of the water at high speed or in rough water. It is impossible to give specific instructions on where to re-site the transducer as it is so dependent on the design of boat. Generally, better results will be obtained nearer the centre line of the boat. If there is only a problem when heeled, consider fitting two transducers with a changeover switch.

6.3.3 Consistently Shows Shallow Depth

Symptom: Display consistently shows a shallow depth between 0 and about 1.5m.

Possible causes:

(a) Faulty transducer. Transducer rings for too long after the transmit pulse is sent and the ringing is interpreted as a shallow return by the depth sounder. On a deep keeled yacht it may be possible to overcome this problem by increasing the minimum depth to just less than the draft of the yacht. The minimum depth is adjusted by changing CAL VAL1 on NOISE.

PARAMTR→NOISE, CALBRATE→CAL VAL1 (MIN DPTH M)

The default setting for minimum depth is 0.7 metres.

(b) Keel echoes. If the transducer has been installed too close to the keel it is possible to get consistent echoes from the keel. The transducer should be re-sited further away from the keel. If this is impossible then increasing the minimum depth to just below the keel can solve the problem but may result in poor performance when the bottom is shaded by the keel. Marginal cases are sometimes caused by side lobes from the main beam from the transducer and may be cured by rotating the transducer in the housing.

(c) Following or crossing the path of another vessel which has left an aerated layer in the water.

6.3.4 Random Deep Depths

Symptom: Display shows random deep depths.

Possible Causes:

(a) Electrical noise. The depth sounder contains circuits and software to reduce its susceptibility to electrical noise, however this can still be a problem if not installed carefully or other equipment is not correctly suppressed. The depth sounder measures the ambient noise and this can be found for display by looking under the PARAMTR Menu. When the boat is stationary electrical equipment should be switched ON and OFF in turn while looking at the depth and noise displays to try and determine the source of the problem.

(b) Acoustic Interference. Other depth sounders and sonar can cause problems. However this is generally only when very close to other boats for example when moored alongside in a crowded marina. Also acoustic noise can be generated by water flow past the transducer and various bits of mechanical machinery.

(c) Mid-water echoes. When outside the range of the depth sounder it is possible that random depths are displayed due to mid-water echoes from shoals of fish or aeration layers.

6.4 ERROR MESSAGES

6.4.1 Error Messages

Following is a list of error messages output on the displays.

Er01	Error detected reading the analogue to digital converter on the depth sounder board. This can be an indication of a fault on the board or that the sea water temperature or the compass signals are outside their normal range. Try disconnecting the sensors in turn.
Er02	Error detected when writing to the analogue to digital converter on the depth sounder board. This can indicate the same problems as Er01.
Err.3	Syntax or parity error on received NMEA data.
Err.4	Checksum error on received NMEA 0183 data.
CAL	Alternating with a function value indicates that it has yet to be calibrated. This will happen after a system reset or if the internal battery is exhausted.
NO SPACE	FFD memory full, too many functions have been declared.
NOT FIND	New function declared without text.

6.5 HALCYON 2000 COMPASS

6.5.1 Shows Heading and CAL Flashing

Symptom: Display flashes a Heading and CAL

Possible Causes:

- (a) The memory in the Halcyon 2000 is empty or has been corrupted. This may be due to a System Reset

being performed or the first time the compass has been installed and not yet been calibrated. Perform a calibration swing to restore normal operation.

(b) After a calibration swing the result is always **FAIL**. There is a source of magnetic deviation near to the Halcyon 2000 compass. Try re-positioning the compass and perform the calibration.

6.5.2 Heading Shows Err

Possible Cause:

The signal from the fluxgate sensor is too big or too small. Try re-positioning the compass. If still showing **Err** set NAVIGATE→COMP CAL, CAL VAL 2 (**RES CAL**) to 1. This will reset the compass. All previous calibrations will be lost and the compass will require a compass swing.

6.5.3 Heading or COMP CAL Shows PHS

Possible Cause:

The compass is in the middle of resetting. The display should show heading and CAL flashing after 20 seconds. A calibration swing will be required.

6.5.4 Two Headings Flashing Alternately

Symptom: Pilot or Halcyon Displays shows two headings flashing alternately

Possible Cause:

The Pilot has not been set to use the Halcyon 2000 as its heading source. Pilot Heading Node must be set to Node 16. If the Halcyon 2000 is not to be the source of heading then it must be unplugged from the network.

6.5.5 True Wind Direction, Tide Set or DR Course Not Functioning Correctly

Symptom: True Wind Direction, Tide Set and DR Course functions are inoperative

Possible Cause:

The Main Processor has not been set to use the Halcyon 2000 as the heading source. Set NAVIGATE→COURSE, CAL VAL 1 (**HDG NODE**) to 16.

6.6 NMEA Alphabetical Index Hydra 2000

6.6.1 NMEA Input Summary

APA	Autopilot Format A
APB	Autopilot Format B
BEC	Bearing and Distance to Waypoint, Great Circle, dead reckoned
BER	Brg. and Distance to W/point, Rhumb, dead reckoned
BOD	Brg. to destination Waypoint from origin W/point
BWC	Brg. and distance to Waypoint, Great Circle measured
BWR	Brg. and distance to Waypoint, Rhumb measured
BWW	Bearing to Waypoint from Waypoint
GGA	Global Positioning System Fix Data
GLL	Latitude and Longitude (versions 1.5 and 2.0)
GLP	Loran C present fix
HDM ¹	Present heading, Magnetic
HDT ²	Present heading, True
HSC ³	Heading, steering
HVD	Magnetic variation, automatic
HVM	Magnetic variation, manually set
MTA	Air Temperature, °Centigrade
MTW	Water Temperature, °Centigrade
RMA	Recommended min. implementation sentence, Loran C
RMB	Recommended min. implementation sentence, Generic
RMC	Recommended min. implementation sentence, GPS
VHW	Heading and Water Speed
VTG	Actual Track and Ground Speed
WBD	Bearing and Distance to Waypoint
WCV	Waypoint Closure Velocity
WDC	Distance to Waypoint, Great Circle
WDR	Distance to Waypoint, Rhumb
XTE	Measured Track Error
XTR	Dead Reckoned Cross Track Error
ZDL	Time and Distance to Layline
ZLZ	Time of Day
ZTG	Time to Waypoint

Notes

1. Function repeated when no B&G fluxgate connected to system. Not used by Autopilot.
2. Displayed when no B&G fluxgate connected to system. Can be used by Autopilot.
3. Re-transmitted only. Not used by Hydra 2000.

6.6.2 NMEA Output Summary

DBT	Depth Below Transducer
GLL	Latitude and Longitude
HDM	Present heading, Magnetic
HDT	Present heading, True
HSC	Heading Steering Command
MTA	Air Temperature, °Centigrade
MTW	Water Temperature, °Centigrade
MWD	Surface Wind Direction and Velocity
MWV	Wind Speed and Angle
VHW	Heading and Water Speed
VLW	Log mileage, Water referenced
VPW	Velocity parallel to true wind, device measured
VTG	Actual Track and Ground Speed
VWR	Wind Relative Bearing and Velocity
VWT	Wind True Bearing and Velocity
XTE	Measured Cross Track Error

Notes

1. NMEA output data is subject to the appropriate sensor or NMEA sentence being connected to the system.
2. Data is not necessarily extracted from all NMEA fields. This avoids the same information being repeated twice on the system.

NMEA Sentences

The following diagrams show the structure of the various NMEA sentences.

1 Autopilot format A (APA)

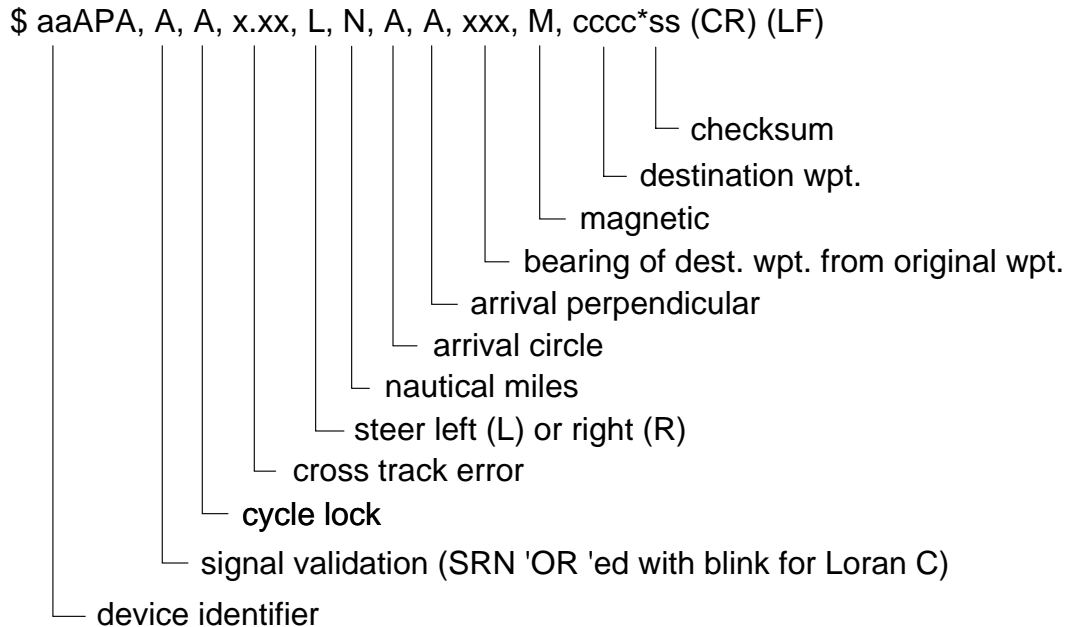

2 Autopilot format B (APB)

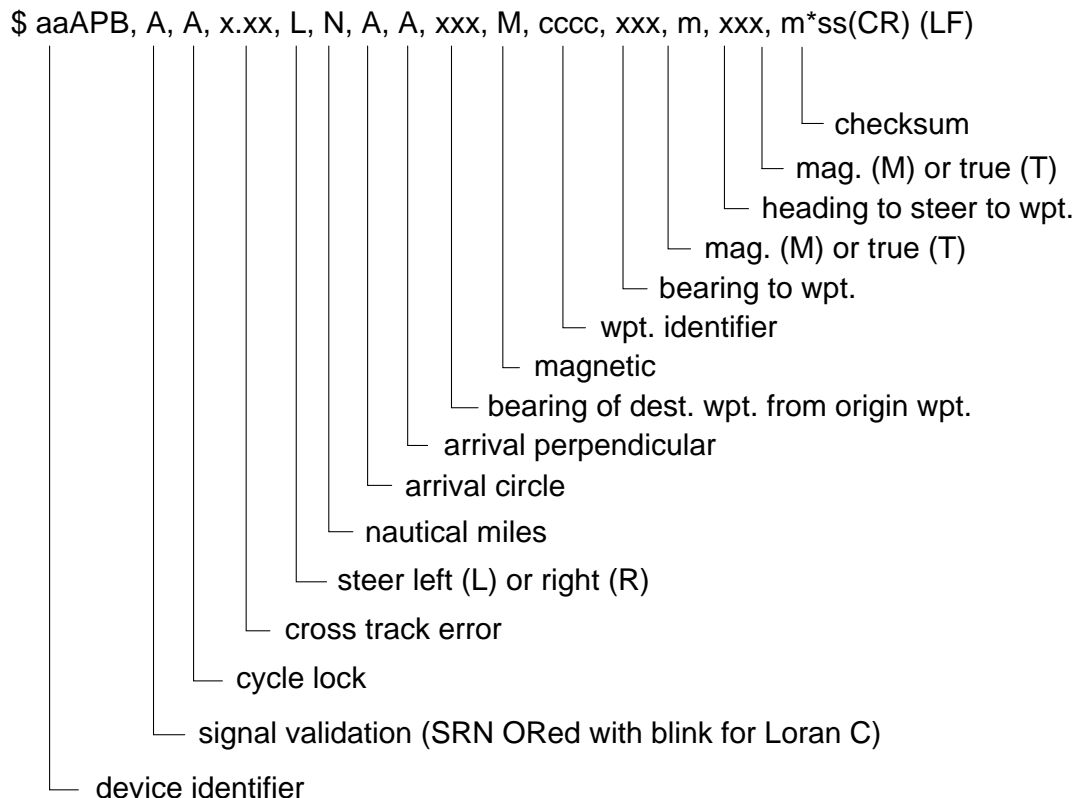

3 Bearing and distance to waypoint, great circle, dead reckoned (BEC)

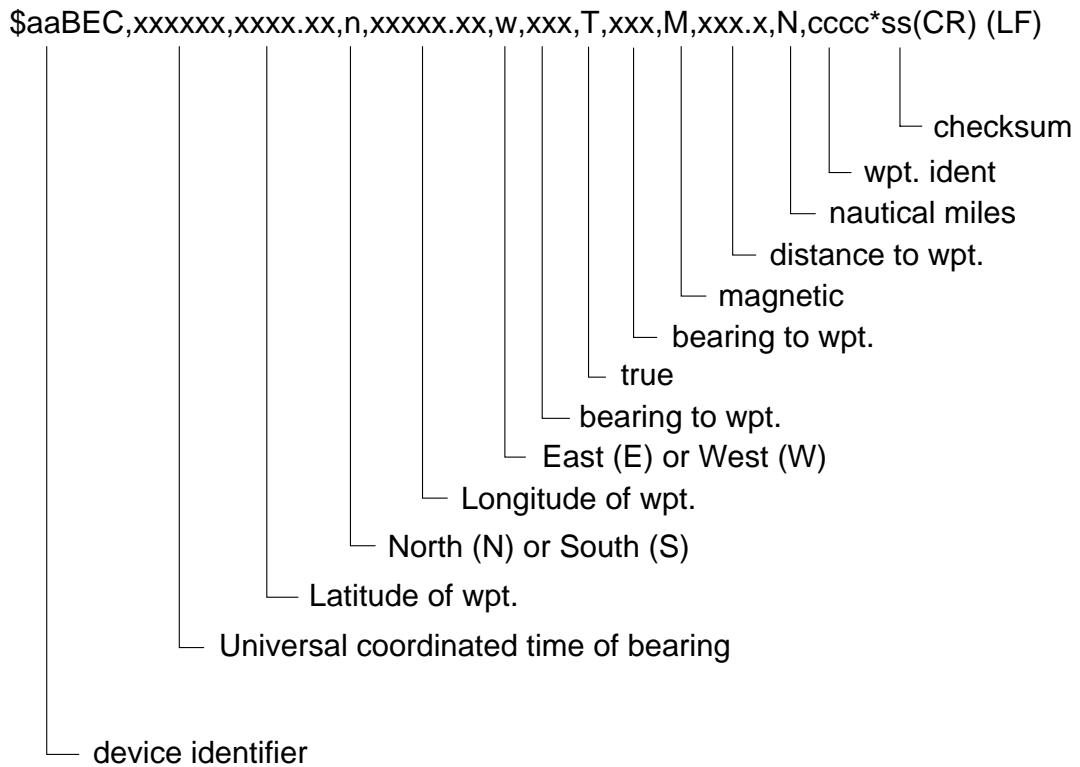

4 Bearing and distance to waypoint, rhumb, dead reckoned (BER)

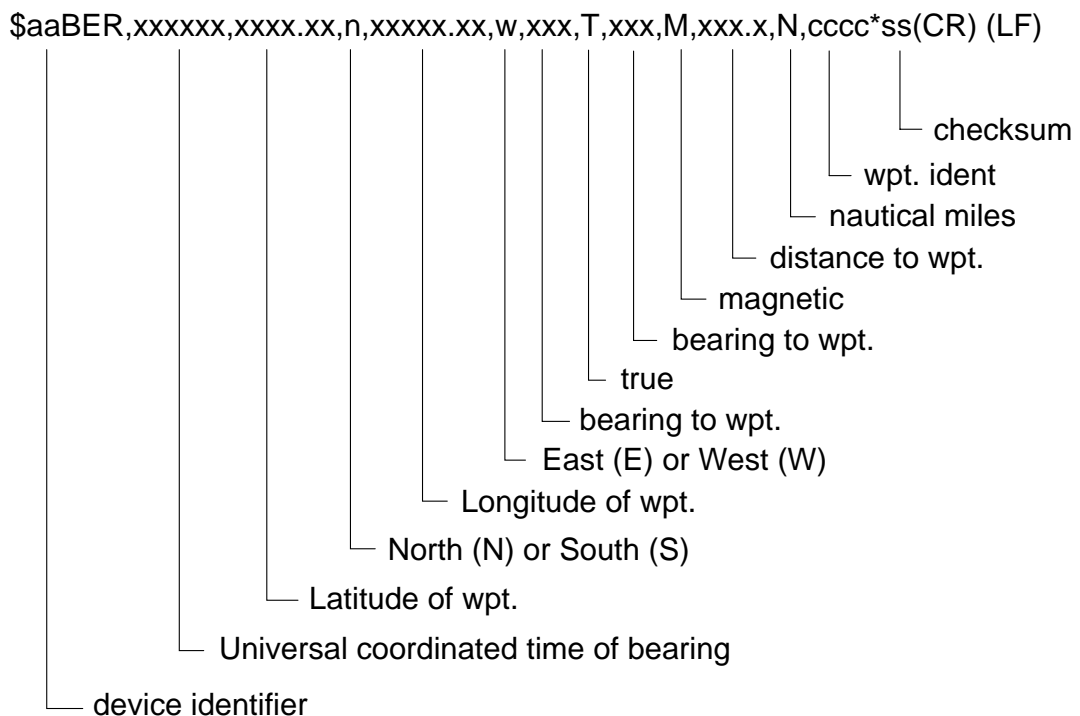

5 Bearing to destination waypoint from origin waypoint, true or magnetic (BOD)

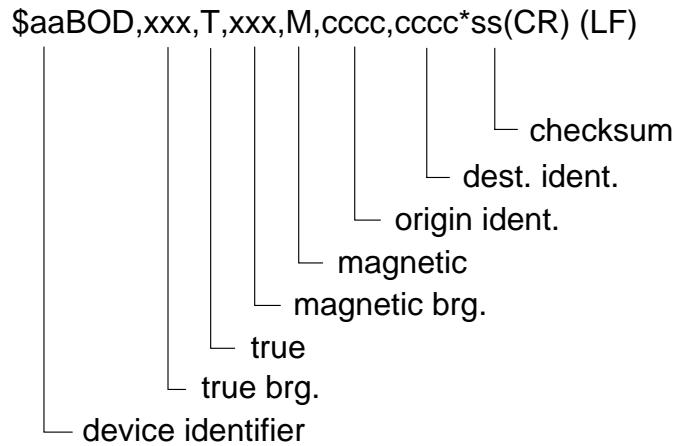

6 Bearing and distance to waypoint, great circle, measured (BWC)

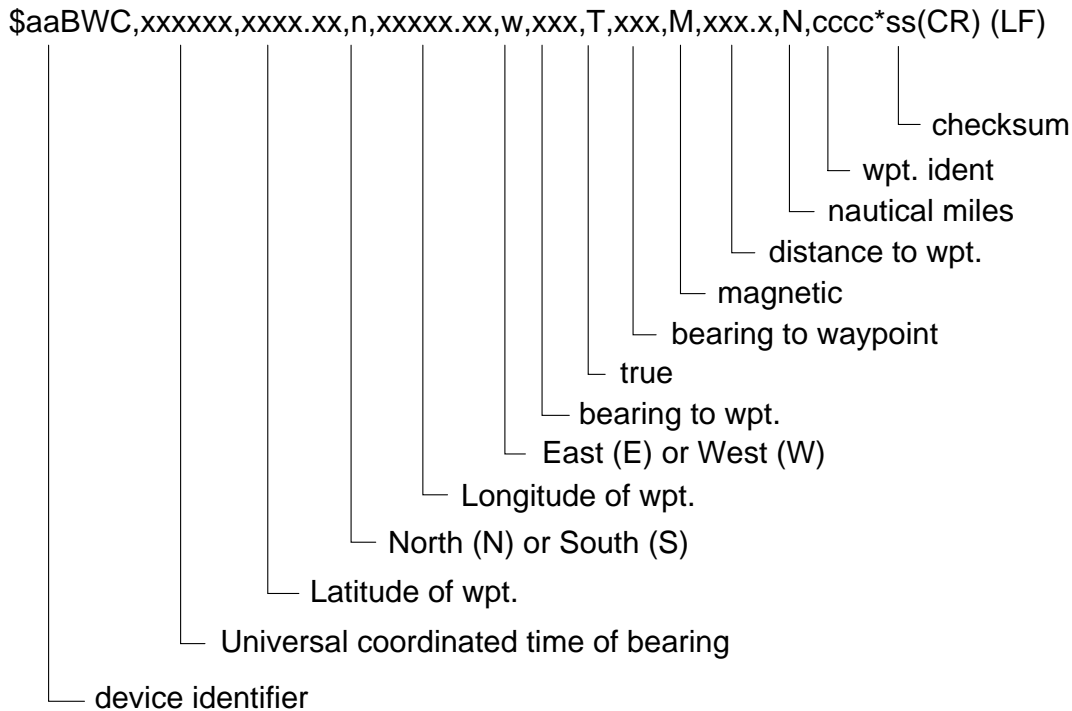

7 Bearing and distance to waypoint, rhumb line, measured (BWR)

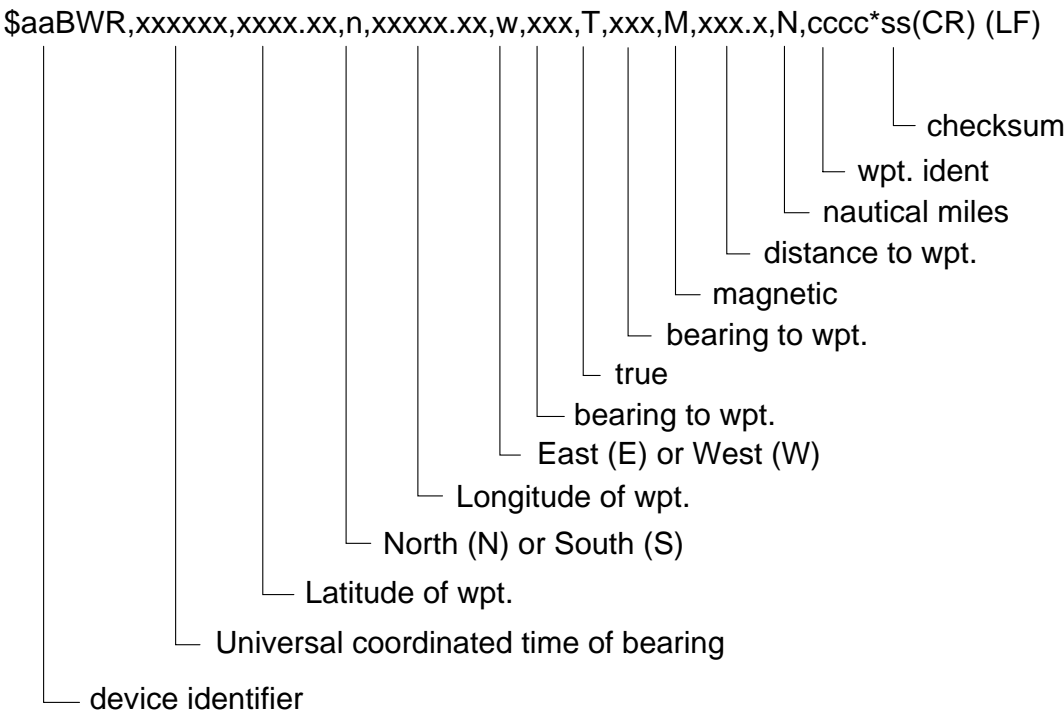

8 Bearing to waypoint from waypoint, true and magnetic (BWW)

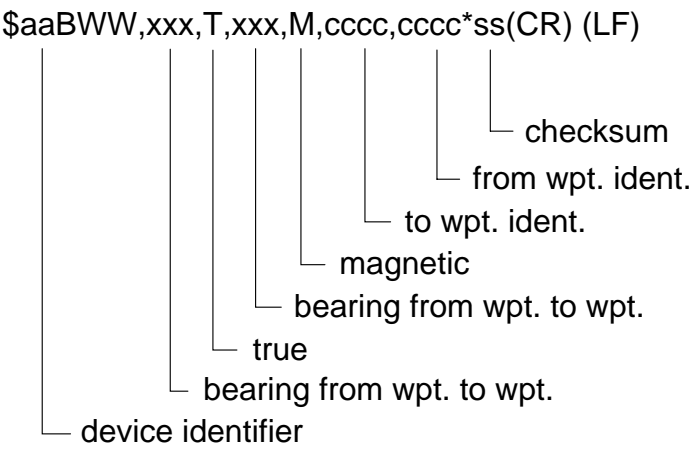

9 Depth of water below transducer (DBT)

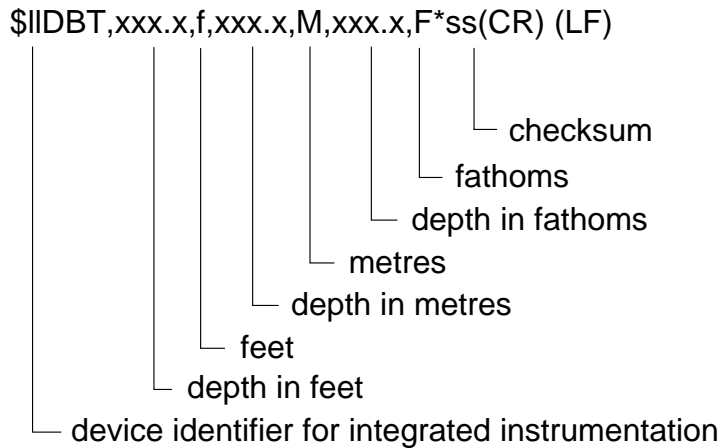

10 Global positioning fix data (GGA)

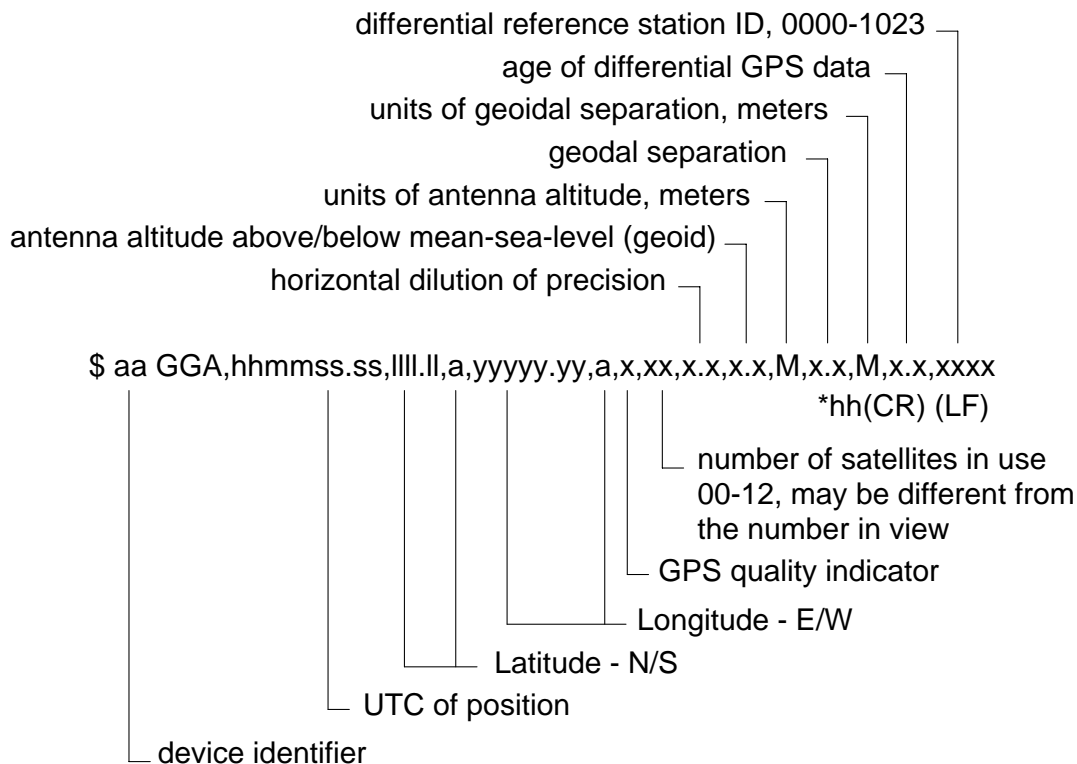

11 Present fix position (GLL)

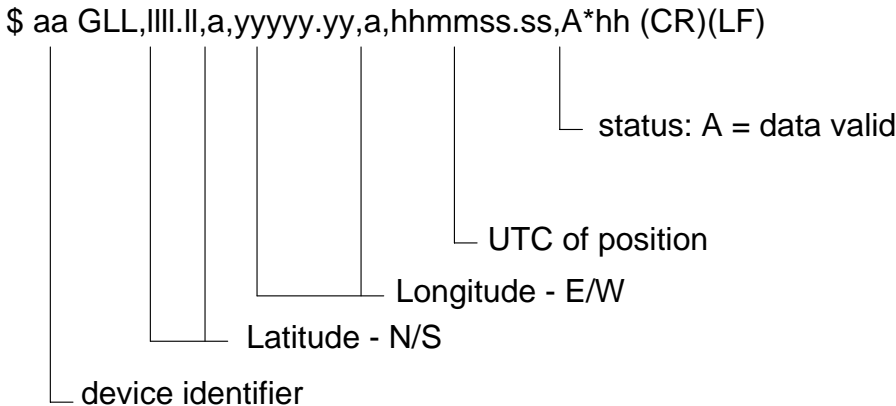

12 Present position fix, Loran - C (GLP)

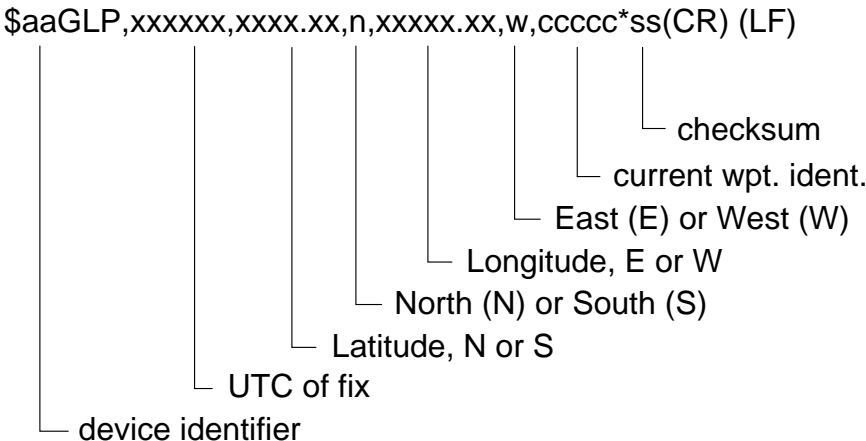

13 Present heading magnetic (HDM)

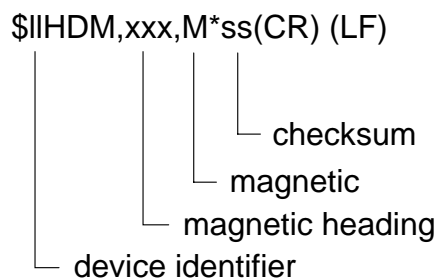

14 Heading degrees, true (HDT)

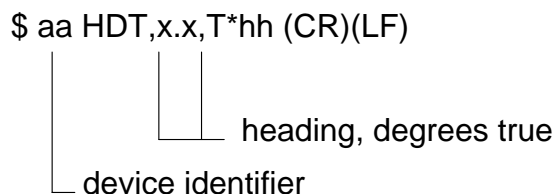

15 Air temperature, Celsius (MTA)

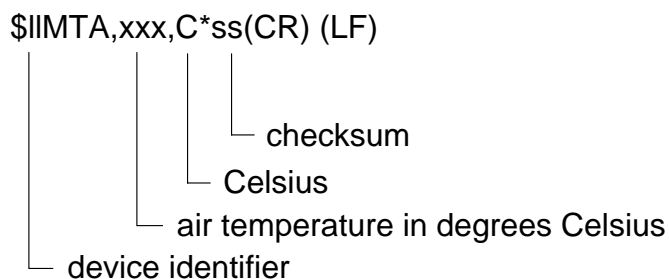

16 Water temperature (MTW)

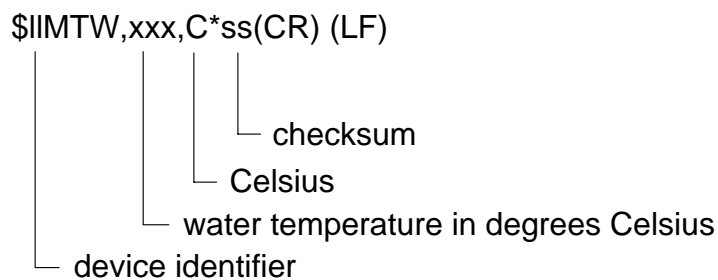

17 Surface wind, direction and velocity (MWD)

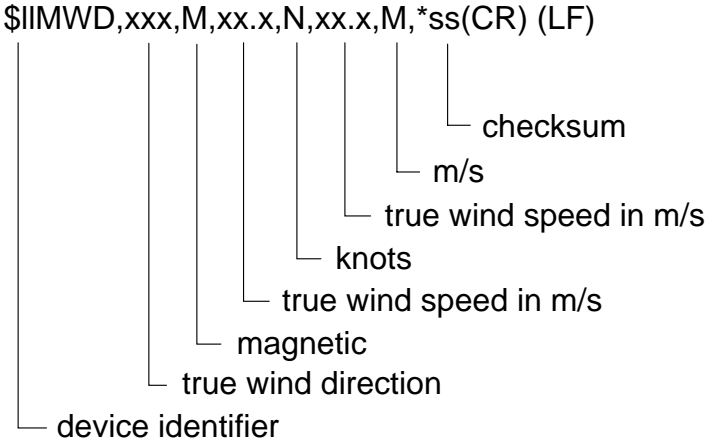

18 Wind speed and angle (MWV)

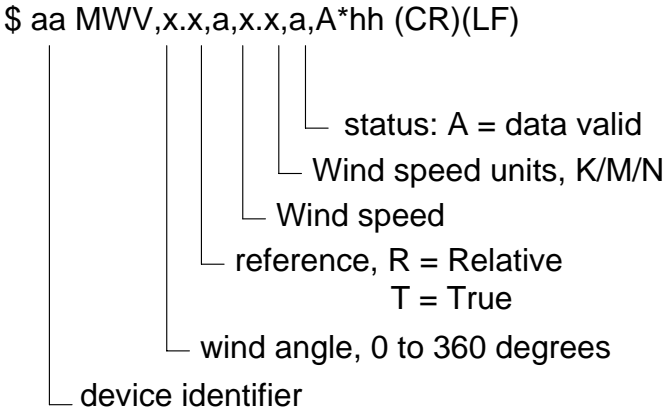

19 Recommended minimum implementation sentence, Loran - C (RMA)

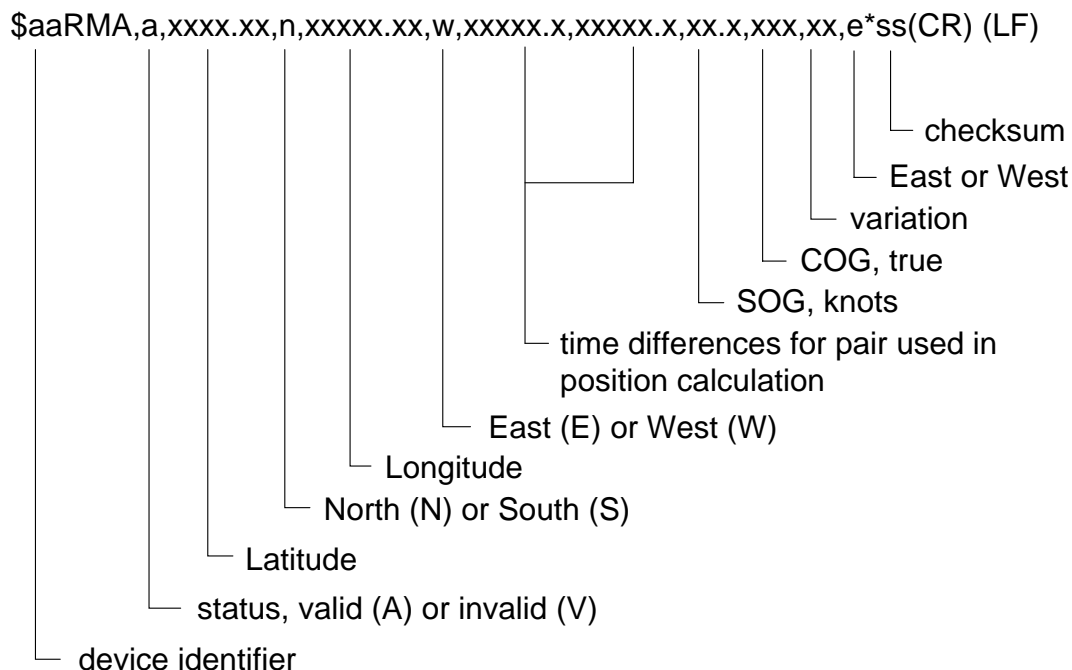

20 Recommended minimum implementation sentence, navigation information (RMB)

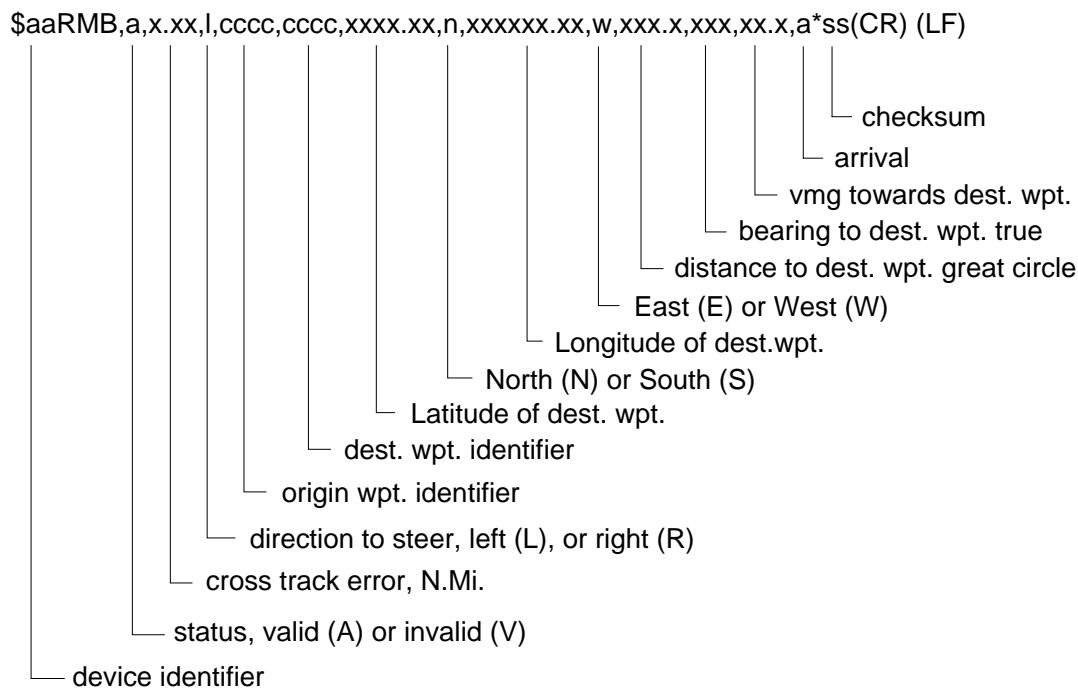

21 Recommended minimum implementation sentence, GPS or transit specific (GPS) (RMC)

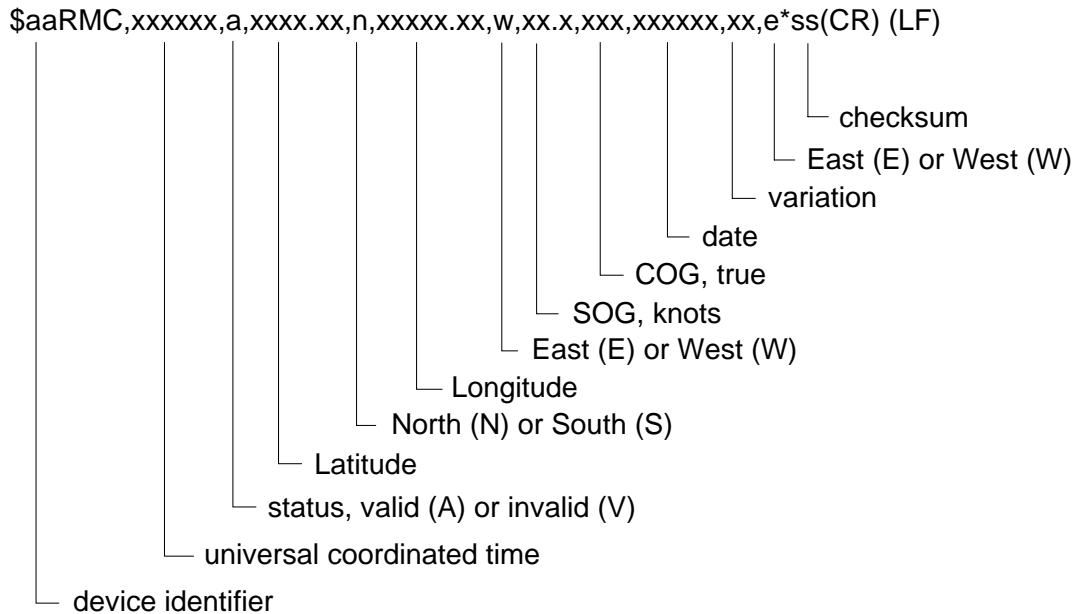

22 Water speed and heading (VHW)

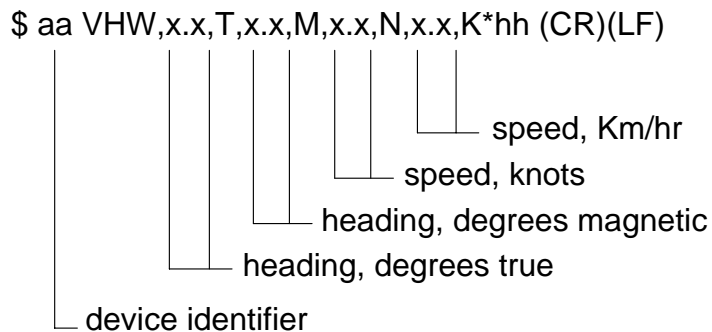

23 Water referenced log mileage (VLW)

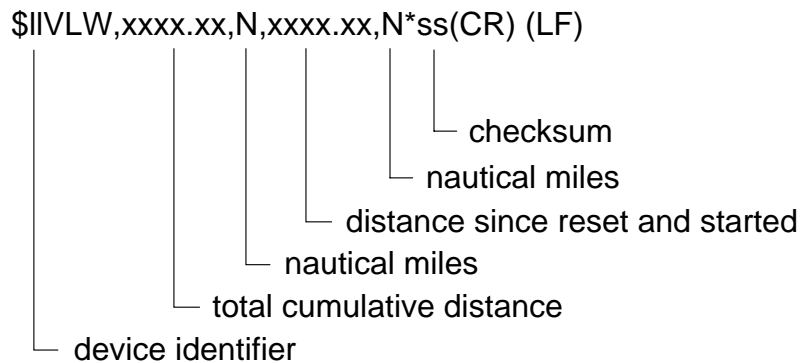

24 Device measured velocity parallel true wind (VPW)

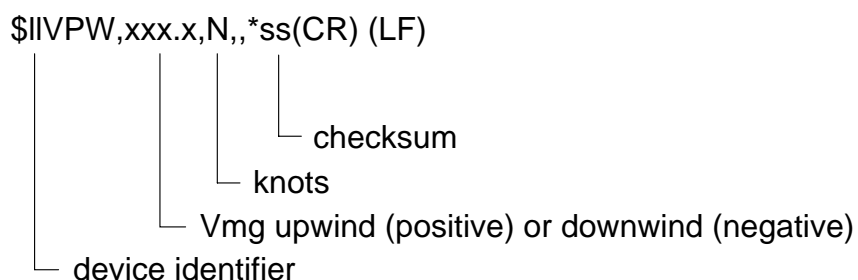

25 Actual track and ground speed (VTG)

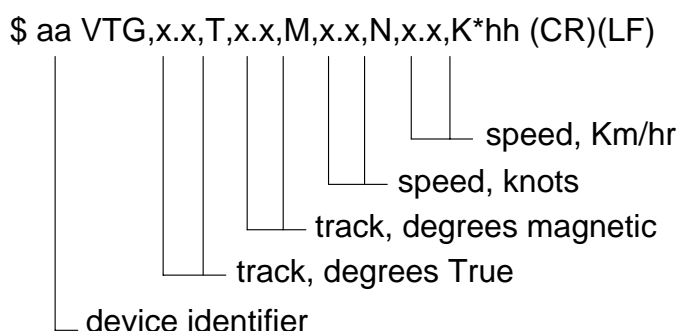

26 Wind relative bearing and velocity (VWR)

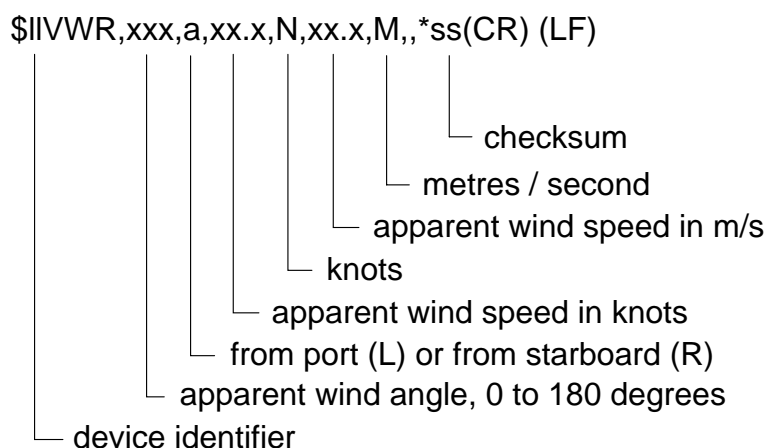

27 True wind relative bearing and velocity (VWT)

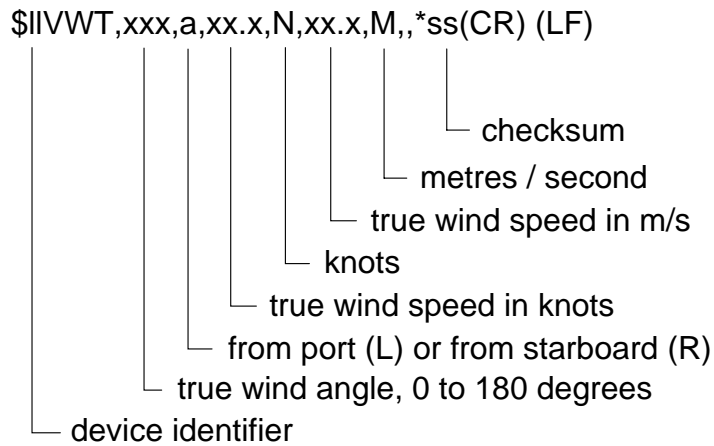

28 Waypoint closure velocity (WCV)

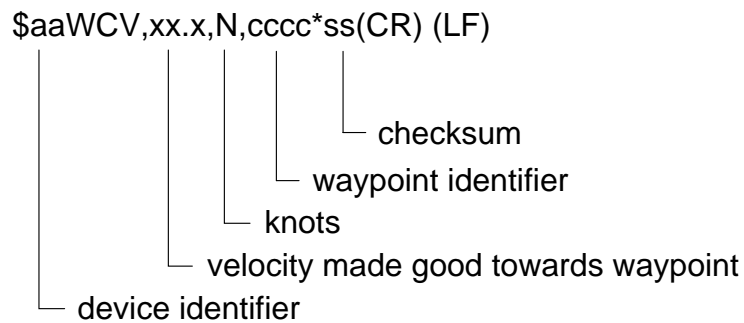

29 Distance to waypoint, great circle (WDC)

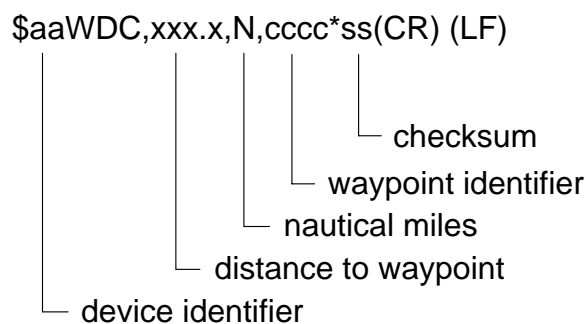

30 Distance to waypoint, Rhumb (WDR)

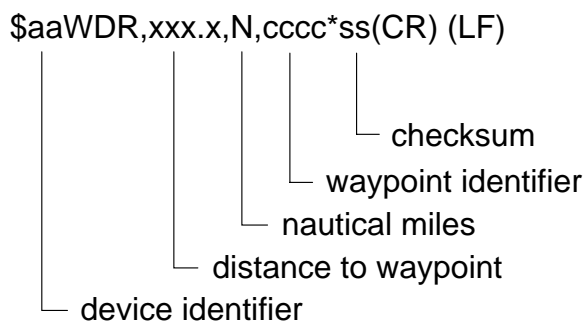

31 Measured cross track error (XTE)

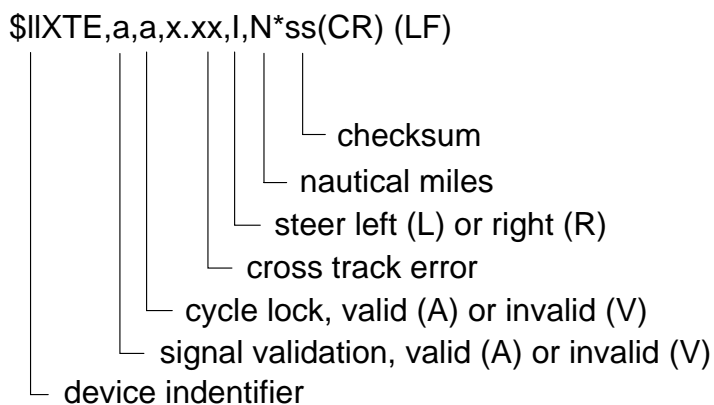

32 Dead reckoned cross track error (XTR)

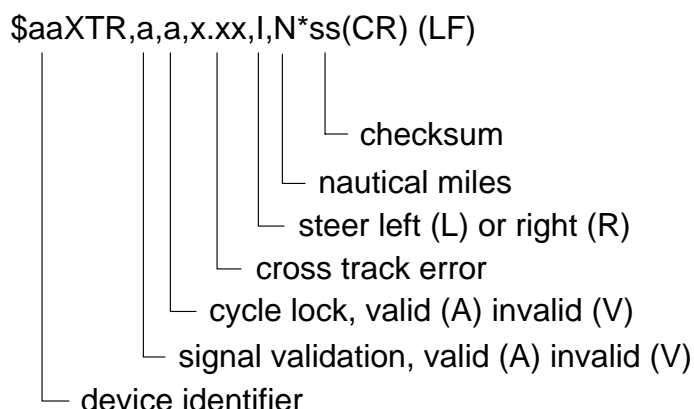

33 Time and distance to layline (ZDL)

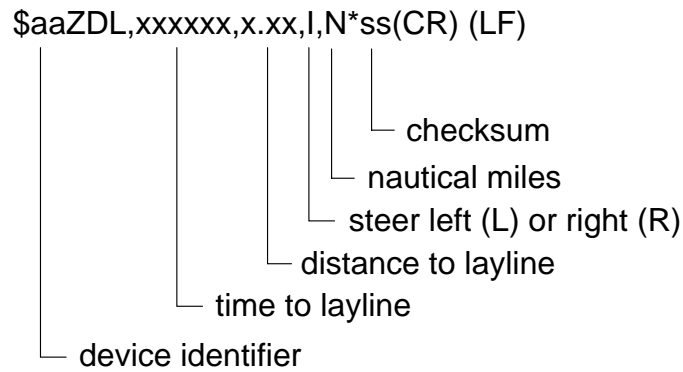

34 Time of day (ZLZ)

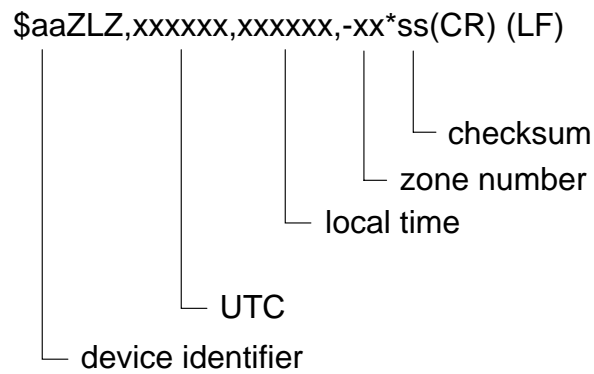

35 Time to waypoint (ZTG)

