



A Simrad Company

h2000 Autopilot User Manual



WARNING

The use of solvent based or chemical cleaners on the Pilot Displays will result in damage and invalidate your warranty.

Premier Way
Abbey Park, Romsey
Hampshire, SO51 9DH, UK

www.BandG.com

© B&G Ltd. 2004

The copyright of this manual is the property of B&G Ltd.

Intentionally Left Blank

h2000 AUTOPILOT USER MANUAL

CONTENTS

Product Liability and Safety Warnings

PART 1 - INTRODUCTION

PART 2 - OPERATING INFORMATION

PART 3 - CALIBRATION

PART 4 - INSTALLATION INFORMATION

PART 5 - OPTIONS

PART 6 - DIAGNOSTIC DATA

PRODUCT LIABILITY AND SAFETY WARNINGS

PRODUCT LIABILITY: Brookes and Gatehouse Ltd. accept no responsibility for the use and/or operation of this equipment. It is the users' responsibility to ensure that under all circumstances the equipment is used for the purposes for which it has been designed.

WARNING - ELECTRICAL HAZARD: This equipment uses high voltage electrical power. Contact with high voltages may result in injury and/or loss of life.

WARNING - CALIBRATION: The safe operation of this equipment is dependent on accurate and correct calibration. Incorrect calibration of this equipment may lead to false and inaccurate navigational readings placing the vessel into danger.

CAUTION: The system electronics are designed for use with a power supply source of 12V dc. The application of any other power supply may result in permanent damage to the equipment.

PART 1 - INTRODUCTION

CONTENTS

Para		Page
1.1	SYSTEM OVERVIEW	1-3
1.2	AUTOPILOT OPERATION	1-4
1.3	CONTROLLING THE AUTOPILOT	1-4
1.4	AUTOPILOT DISPLAY	1-5
1.5	HAND-HELD CONTROLLER	1-6
1.6	JOYSTICK	1-7
1.7	MAN OVERBOARD BUTTON	1-8

ILLUSTRATIONS

Fig No		Page
1.1	Autopilot Display	1-5
1.2	Hand-held Controller	1-6
1.3	Joystick	1-7
1.4	Man Overboard Button	1-8

Intentionally Left Blank

PART 1 - INTRODUCTION

1.1 SYSTEM OVERVIEW

The h2000 Autopilot fully integrates with, and complements the Hydra 2000, Hercules 2000 and HS2000 instrument systems, both in terms of style and performance. The instrument system transmits sensor information via the B&G Fastnet Data cabling to the Autopilot Computer Unit.

The Autopilot Computer processes the sensor data and then sends signals to the rudder driving system (linear ram, rotary drive or hydraulic pump) to steer the vessel on the desired course. The complex learning algorithms (a form of artificial intelligence) used in the Autopilot Computer, ensure that the steering performance is optimised regardless of the weather conditions, and quickly responds to any changes that may occur.

Control of the Autopilot is via the keys on any one of the dedicated Autopilot displays. Each display acts as a master allowing control of the Autopilot from any station.

The h2000 Autopilots are available with a wide range of powerful and reliable 12V or 24V dc rudder drive units suitable for boats of over 7m (23ft). The control electronics (the Autopilot Computer) are supplied as ACP1 or ACP2 (Advanced Control Programming) depending on the size of vessel, power requirements and options that have been selected and fitted.

The h2000 Autopilot can be used for both sail and powerboats that have a Hydra 2000, Hercules 2000 or HS2000 System installed.

If the relevant sensor data is available, the Autopilot offers the following Steering Options:

- (a) **Steer to Compass** - Uses data from the Autopilot Gyro or Instrument Compass to maintain the selected compass heading.
- (b) **Steer to Wind** - Uses data from the Instrument Masthead Unit (not powerboats) to steer to the Apparent Wind Angle.
- (c) **Steer to Waypoint** - Uses NMEA data from a compatible Position Fixer, Chart Plotter or PC charting package.

- (d) **Power Steering** - Allows the Autopilot direct control of the steering.
- (e) **Steering to Optimum Wind Angle** - This option is only available when a Hercules Performance Processor is installed.

Other options for the h2000 Autopilot include the following:

- (a) Hand-held Controller.
- (b) Joystick Steering.
- (c) Man Overboard (MOB) alarm and recovery assistance.

1.2 AUTOPILOT OPERATION

Part 2 - Operating Information describes how to operate the h2000 Autopilot after it has been installed, commissioned and sea trials have been successfully completed. Information relating to calibration, commissioning, and installation are given in Parts 3 and 4 of this Manual, respectively.

WARNING - NAVIGATION HAZARD: The Autopilot must be fully commissioned and a satisfactory sea-trial completed before the Autopilot is used to steer the vessel. Failure to do so could endanger life and/or other vessels.

1.3 CONTROLLING THE AUTOPILOT

The Autopilot Display is the primary method of controlling the Autopilot. Several displays positioned around the vessel allow Autopilot control from any station. Each display acts as a Master providing readouts of autopilot course, actual heading and autopilot function. Operational control is via a keypad.

1.4 AUTOPILOT DISPLAY

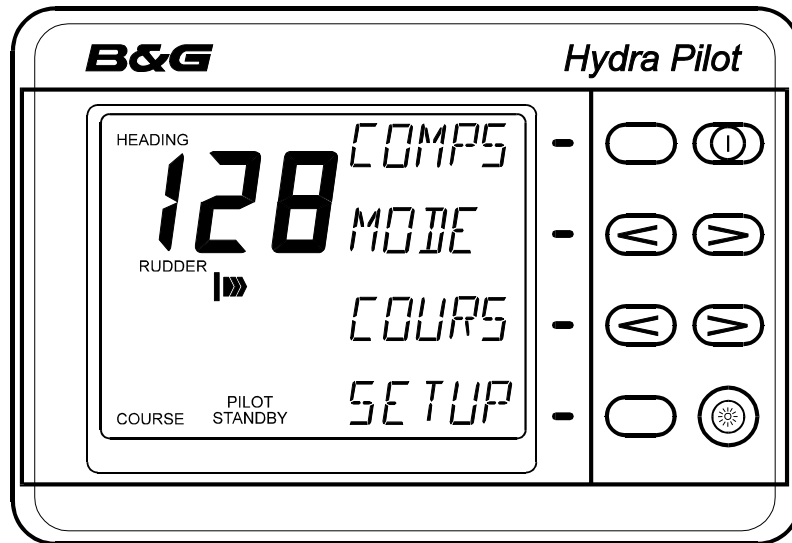

Fig 1.1 - Autopilot Display

The backlit Liquid Crystal Display (LCD) shows the following information:

- (a) **Large Digits** (top centre) - The current heading as provided by the Autopilot Compass or Instrumentation System.
- (b) **Rudder Legend** (centre) - The mode selected for the analogue bar immediately below. This can be set to RUDDER or OFF COURSE.
- (c) **Rudder Bar Display** (centre) - Analogue indication of Rudder Angle in increments of 5° up to 35° . This can be set to show either OFF COURSE or RUDDER ANGLE.
- (d) **Autopilot Legend** - (bottom centre) - Indicates the Autopilot Operational Status. This can be set to either STANDBY or ON.
- (e) **Key Legends and Keypad** (right top to bottom) - The legends change according to the operating mode selected, assigning different functions to each key as required. Pressing the key(s) adjacent to each legend will cause an action, e.g. Change of Course, or provide a list of options and selections. These lists are referred to as Menus and are fully described in Part 2 - Operating Information.

(f) **Red Off Key** (top right of keypad) - This key disengages the Autopilot and returns the boat to Manual Steering. It has no other function.

(g) **Lights Key** (bottom right of keypad) - This key turns the LCD back lighting ON and OFF, and allows three levels of illumination to be selected for all displays (including Instrument System FFDs) under system control. It has no other function.

Note

The Autopilot can be disengaged at any time from any mode or menu by pressing the **Red Off Key**.

1.5 HAND-HELD CONTROLLER

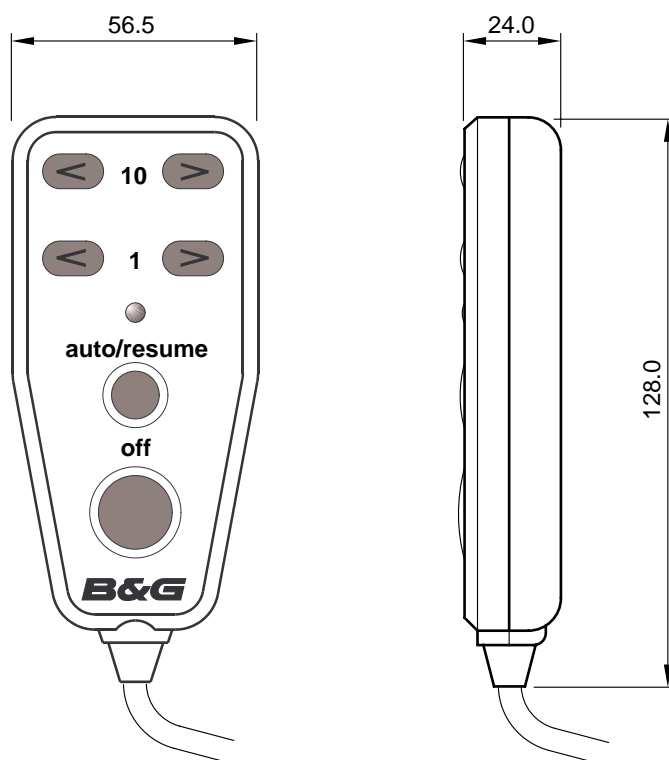

Fig 1.2 - Hand-held Controller

The Hand-held Controller provides remote control of the h2000 Autopilot. The six keys used for dedicated functions are as follows:

- (a) 10 degree course change (Port/Starboard).
- (b) 1 degree course change (Port/Starboard).

- (c) Auto/Resume - Autopilot engage and return to course.
- (d) Off - Autopilot disengage.

1.6 JOYSTICK

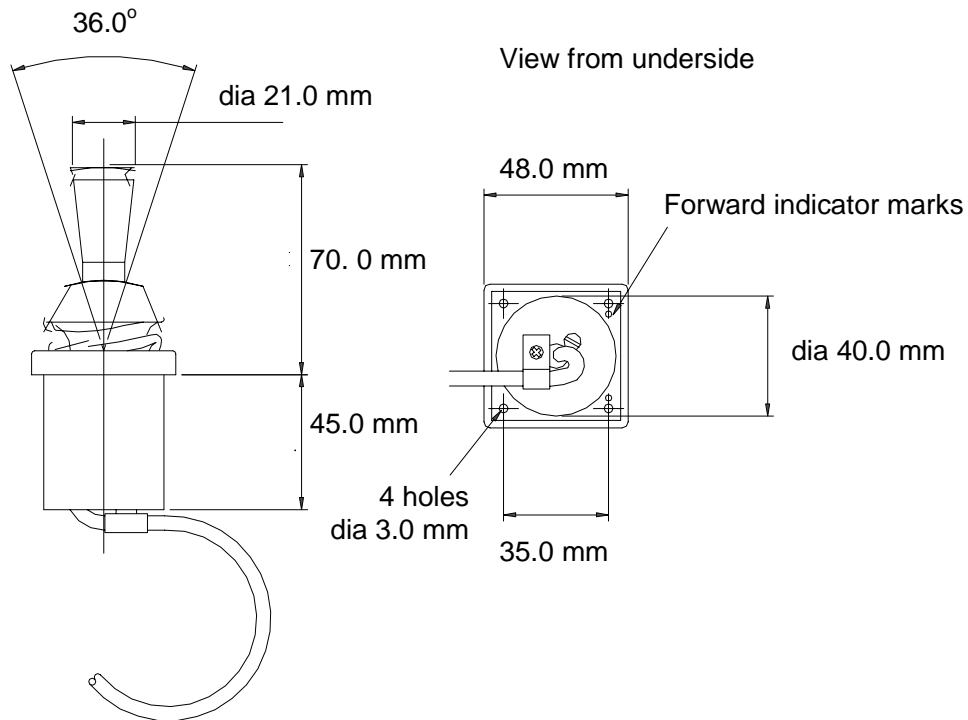

Fig 1.3 - Joystick

The Joystick allows direct control of the rudder via the autopilot control electronics. The unit is deck-mountable, allowing it to be used inside or outside the steering positions. A 10m/30ft 6-core screened cable connects the unit directly into the ACP unit's terminals. Joystick steering is engaged and disengaged with the separate red button. The lever can only be moved to port and starboard.

There are two modes of joystick operation available to the Helmsman, these are as follows:

- (a) **Normal Steering (Norm)** - The rudder moves in the direction of the Joystick. When the Joystick is returned to the central position the rudder movement stops. The greater the movement of the Joystick the faster the response of the rudder.

(b) **Proportional Steering (Prop)** - The position of the rudder follows the position of the Joystick. When the Joystick returns to the central position the rudder returns to its initial position.

1.7 MAN OVERBOARD BUTTON

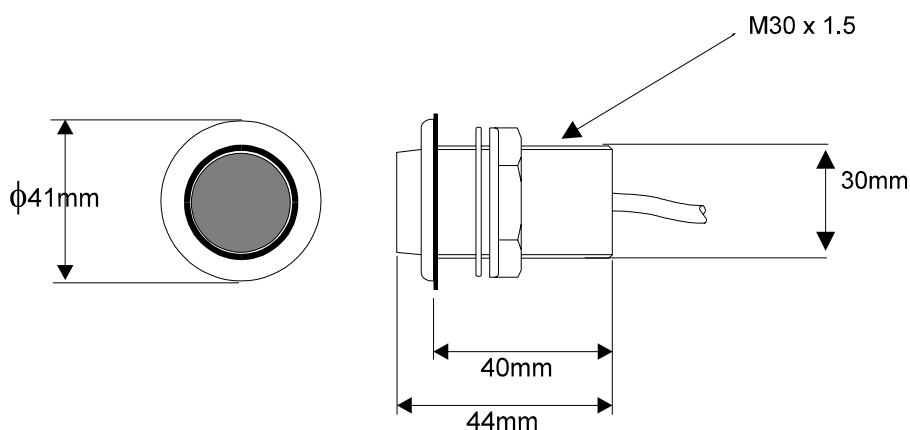

Fig 1.4 - Man Overboard Button

The Man Overboard Button (MOB) is an optional extra that activates the Autopilot Man Overboard Alarm Procedure to assist in the recovery of the person, or persons, that may have been lost overboard. It may be used when the Autopilot is engaged or disengaged.

For this facility to operate, a speed sensor input must be available. It will not work with a user entered fixed speed or Speed Over Ground from a Position Fixer.

Sailboats, because of the need to tack or gybe, must use Manual recovery. The bearing and distance displays must be followed and the boat steered back, either manually or under Autopilot Control, to the person(s) in the water.

Powerboats can use the Autopilot for Automatic Recovery. When the MOB is operated the Autopilot will control the steering to execute a 'Williamson Turn' and return the boat on a reciprocal course.

PART 2 - OPERATING INFORMATION

CONTENTS

Para		Page
2.1	SWITCHING ON	2-3
2.2	MODE SELECTION	2-4
2.2.1	Introduction	2-4
2.2.2	Mode Selection	2-4
2.3	STEER TO COMPASS	2-4
2.3.1	Introduction	2-4
2.3.2	Selecting Compass Mode	2-5
2.3.3	Engaging the Autopilot	2-5
2.3.4	Dis-engaging the Autopilot	2-5
2.3.5	Changing the Autopilot Course	2-6
2.3.6	Pre-setting the Autopilot Course	2-7
2.3.7	Pre-setting the Next Leg	2-7
2.4	STEER TO WIND INTRODUCTION	2-8
2.4.1	Hydra 2000 and Hydra Autopilot	2-8
2.4.2	Hercules and Hercules Autopilot	2-8
2.4.3	Selecting Wind Mode	2-9
2.4.4	Engaging the Autopilot	2-9
2.4.5	Dis-engaging the Autopilot	2-10
2.4.6	Steer to Wind Adjustments	2-10
2.4.7	Pre-setting the Target AWA	2-11
2.4.8	Auto Tack	2-12
2.4.9	Auto Gybe	2-13
2.4.10	Gybe Zone	2-13
2.4.11	Using the Gybe Key	2-14
2.5	STEER TO WAYPOINT	2-13
2.5.1	Steer to Waypoint Introduction	2-14
2.5.2	Selecting the Waypoint Mode	2-15
2.5.3	Engaging the Autopilot	2-15
2.5.4	Dis-engaging the Autopilot	2-16
2.5.5	Changing the Autopilot Course	2-16
2.5.6	Returning to Original Course	2-17
2.5.7	Waypoint Arrival Next Leg	2-17

CONTENTS (Contd.)

Para		Page
2.6	POWER STEER	2-18
2.6.1	Introduction	2-18
2.6.2	Selecting Power Steer Mode	2-18
2.6.3	Engaging the Autopilot	2-19
2.6.4	Dis-engaging the Autopilot	2-19
2.6.5	Fine Rudder Adjustments	2-19
2.6.6	Coarse Rudder Changes	2-20
2.6.7	Mid Key	2-20
2.7	JOYSTICK STEERING	2-20
2.7.1	Introduction to Joystick Steering	2-20
2.7.2	Engaging the Autopilot	2-21
2.7.3	Dis-engaging the Autopilot	2-22
2.7.4	Normal Steering	2-22
2.7.5	Proportional Steering	2-22
2.8	SET-UP OPTIONS	2-23
2.8.1	Manual Response Set-Up (RESP)	2-24
2.8.2	Mode Set-Up (MODE)	2-25
2.8.3	Automatic Response Set-Up (ARESP)	2-26
2.8.4	Recovery Mode Sensitivity (RECOV)	2-28
2.8.5	Speed Set-Up (SPEED)	2-29
2.8.6	Off Course Set-Up (Off-C)	2-30
2.8.7	Compass Damping Set-Up (C DMP)	2-31
2.8.8	NMEA Source Set-Up (N SRC)	2-32
2.8.9	Course Alarm Set-Up (CRS A)	2-34
2.8.10	Watch Alarm Set-Up (WATCH)	2-35
2.8.11	Back Lighting Set-Up (LIGHT)	2-36
2.8.12	Joystick Set-Up (JYSTK)	2-37
2.9	AUTOPILOT INFORMATION ON FFD	2-38
2.9.1	Autopilot Course (PLT CRSE °M)	2-38
2.9.2	Rudder Angle (RUDDER °)	2-38
2.9.3	Off Course Error (OFF CRSE °)	2-38
2.9.4	Man Overboard Facility (MAN OVER)	2-38
2.9.5	Autopilot Faults and Errors (PLT ERR)	2-38
2.10	MAN OVERBOARD FACILITY	2-39
2.10.1	Man Overboard Procedure	2-39
2.10.2	Manual Recovery (All Boats)	2-40
2.10.3	Automatic Recovery (Power Only)	2-40

PART 2 - OPERATING INFORMATION

2.1 SWITCHING ON

The h2000 Autopilot has two power supplies (instrument and heavy duty) connected via circuit breakers and/or fuses. The Autopilot Computer and Autopilot Displays are powered via the Fastnet data cable and share the same source of supply as the Hydra, Hercules or HS2000 Instrument System.

The hydraulic ram, rotary drive or hydraulic pump supplies are routed via the Autopilot Computer. The heavy-duty supply is dedicated to the rudder drive unit and is connected via a separate heavy-duty fuse or circuit breaker.

To switch the Autopilot ON, proceed as follows:

- (1) Switch ON the heavy-duty power supply for the rudder drive unit.
- (2) Switch ON the instrument supplies.

The Autopilot will only operate if both the heavy duty and instrument supplies are switched ON.

Notes

1. If the Autopilot Display indicates **Fault 103** when engaged for the first time, check that the heavy-duty drive supply is switched ON.
2. If the Autopilot Display indicates the Fault Message above, switch ON the heavy-duty supply and clear the fault message.
3. If the Autopilot Display shows **Fault 104** when engaged, this indicates that there is no boat speed input from the sensor. For example, this would occur if the Autopilot were switched on at the dockside.
4. To clear the Fault Message, press the key next to the **FAULT** legend on any Autopilot Display twice. Alternatively, press the **Enter** Key on any FFD twice.

2.2 MODE SELECTION

2.2.1 Introduction

The Autopilot software automatically determines which modes of operation are available depending on whether the vessel is a powerboat or a sailboat. The Autopilot also receives Waypoint or Wind data via the Fastnet databus from either a compatible position fixer or the Masthead Unit.

At initial switch ON the Autopilot will be in Standby and Steer to Compass (**COMPS**) mode.

2.2.2 Mode Selection

The mode is changed by pressing the key next to the **MODE** legend on the FFD.

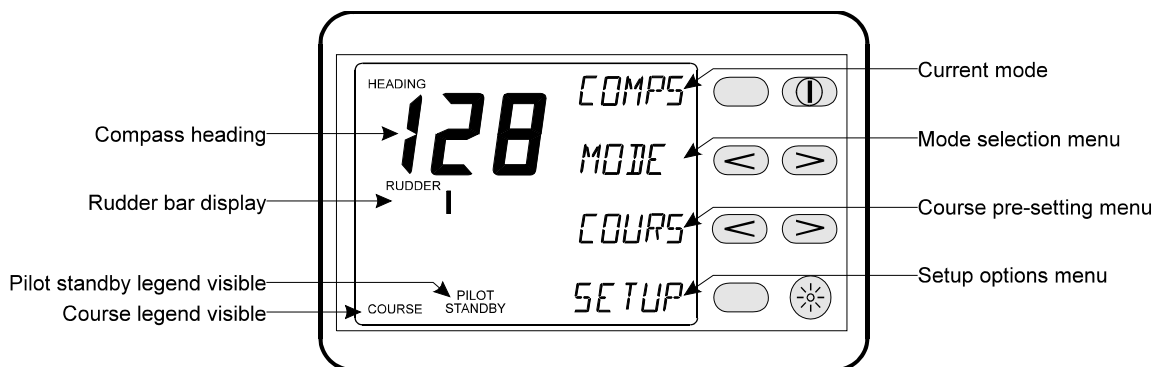

Each mode of steering is described in the following sections.

2.3 STEER TO COMPASS

2.3.1 Introduction

Steer to Compass is available with all Autopilot configurations for sailboats and powerboats and is the basic method of Autopilot steering. The boat is steered on the desired compass heading and the Autopilot is engaged with a single key press. The Autopilot will steer using heading data either from a Halcyon 2000 Compass connected to the Fastnet databus, a Gyro sensor connected directly to the Autopilot processor, or from the B&G Halcyon Gyro Processor.

2.3.2 Selecting Compass Mode

Press the < Key next to the **MODE** legend until **COMPS** appears on the top line.

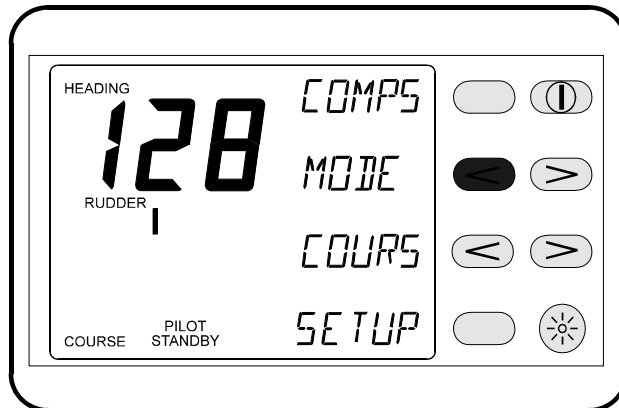

2.3.3 Engaging the Autopilot

(1) From the Autopilot Display and with the boat steered on the desired course, press the Key next to the **COMPS** legend.

(2) From the Hand-held Controller steer the boat onto the desired course, press the **Auto/Resume** Key to engage the Autopilot.

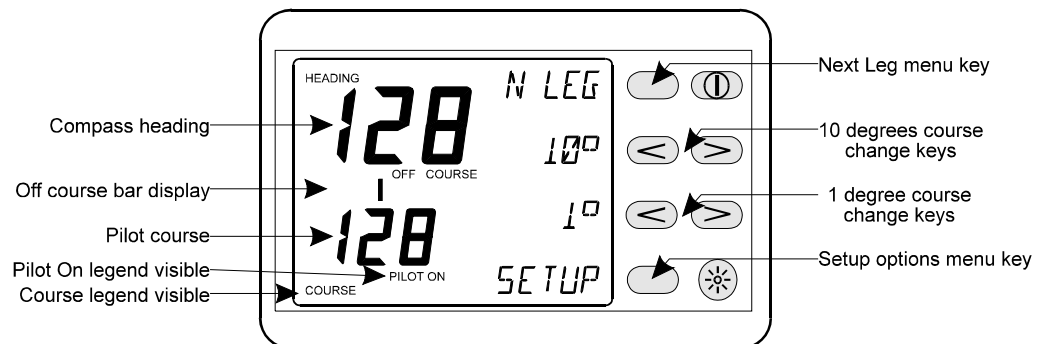

2.3.4 Dis-engaging the Autopilot

Note

When the Autopilot is engaged, the Instrument System FFDs Power-Off Key is disabled, preventing accidental switching OFF of the Autopilot and Instrument System.

(1) At any Autopilot Display press the **Red Off** Key. The Autopilot immediately disengages and returns the boat to manual steering.

(2) From the Hand-held Controller press the **Red Off** Key. The Autopilot immediately disengages and returns the boat to manual steering.

2.3.5 Changing the Autopilot Course

Note

The Autopilot can be immediately disengaged and the steering returned to manual control by pressing the **Red Off** Key on any Autopilot Display or Hand-held Controller.

- (1) **Fine Adjustments** - Multiple key operations are added together to give the required course change, e.g. for a 5° course change press the 1° button 5 times.

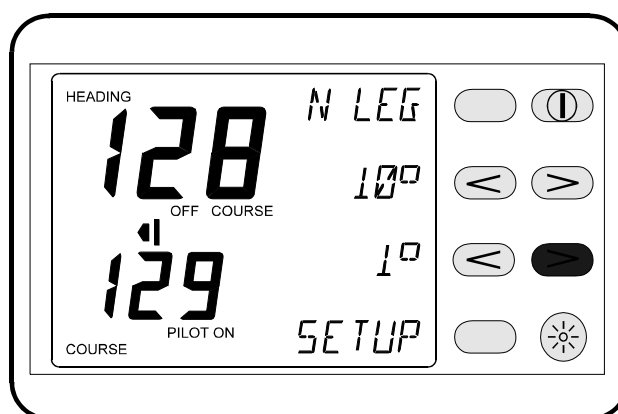

- (2) **Coarse Adjustments** - Multiple key operations are added together to give the required course change, e.g. for an 11° course change press the 10° + 1° button.

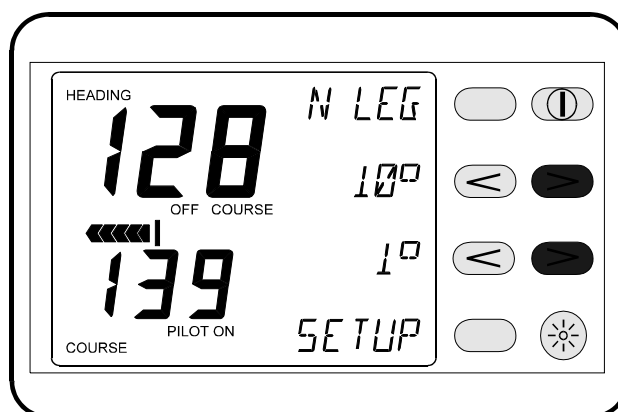

(3) **Temporary Changes (Dodging)** - At any Autopilot display press the **>** Key next to the **10°** legend to change the Autopilot course to starboard by 10°. When the key is pressed, the last course is stored in the Autopilot Computer course memory. The Autopilot course digits alternate between current and last course: Press the **<** Key next to the **10°** legend to change the Autopilot course to port by **10°**. The last course memory works as described above.

At the Hand-held Controller press the **Auto/Resume** Key to return to the original course.

USER TIP

The **10°** and **Last** Keys can be used to "dodge" around obstacles in the Autopilot's course. Multiple key operations are added together to give the required course change, e.g. for a 20° course change press the **10°** Key twice.

Note

If the **1°** Key is pressed immediately after pressing the **10°** Key, the course memory is cleared and the last course cannot be recalled. To return to the original course use the **Reciprocal** Key.

2.3.6 Pre-Setting the Autopilot Course

(1) At any Autopilot Display, with the Autopilot System in Standby, press the key next to the **COURS** legend to display the Course Pre-setting Menu.

(2) Press the **<** Key (Decrease) and **>** Key (Increase) next to the **< < > >** legend to alter the Autopilot course. This is displayed on the LCD lower digits.

(3) Press the key next to the **COMPS** legend to engage the Autopilot on the new pre-set course.

2.3.7 Pre-Setting the Next Leg

(1) At any Autopilot Display and with the Autopilot engaged, press the key next to the **N LEG** legend to display the Next Leg Pre-Setting Menu.

(2) Press the < Key (Decrease) and > Key (Increase) next to the < < > > legend to alter the Autopilot legend to pre-set the Autopilot course, displayed on the lower digits.

The keys next to the **10°** legend allow course dodges if required.

(3) When the course change is required, press the key next to the **ENTER** legend.

The Autopilot will then steer the boat on to the pre-set next course.

The course change can be abandoned at any time by pressing the key next to the **QUIT** legend.

USER TIP

The Next Leg facility can be used to pre-set the next course change before arriving at a Waypoint, point of interest or navigational mark. It allows you to plan ahead.

2.4 STEER TO WIND INTRODUCTION

This mode of steering is only available to sailing boats that have a Hydra or Hercules System fitted with a Masthead Unit.

2.4.1 Hydra Autopilot

When **WIND** is selected with a Hydra Autopilot System, the Autopilot will steer a course that maintains a pre-defined Wind Angle. If the Apparent Wind Angle (AWA) shifts, the Autopilot will alter course so that the actual wind angle remains the same.

2.4.2 Hercules Autopilot

The Hercules Autopilot System has the additional feature of Steer to Optimum Wind Angle. Data from the Hercules System's polar tables, stored in the Performance Processor, allow the boat to sail at the Optimum Wind Angle and is particularly useful for achieving maximum VMG (Velocity Made Good) to windward.

2.4.3 Selecting Wind Mode

(1) At the Autopilot Display press the key next to the **MODE** legend until **WIND** appears on the top line.

The Apparent Wind Angle (AWA) displayed on the bottom digits is the same as the displayed **APP W/A** on the Instrument System. The position of the bar indicates the direction of AWA:

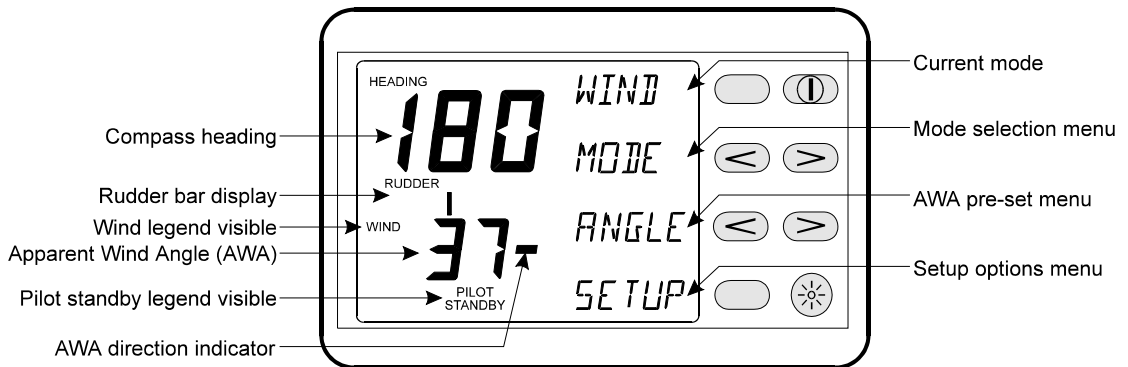

Bar to the right of the digits, wind angle to starboard.

Bar to the left of the digits, wind angle to port.

2.4.4 Engaging the Autopilot

(1) At any Autopilot Display steer the boat until the desired wind angle is displayed. Press the key next to the **WIND** legend to engage the Autopilot.

(2) From any Hand-held Controller steer the boat until the desired wind angle is displayed. Press the **Auto/Resume** Key to engage the Autopilot with the Hand-held Controller.

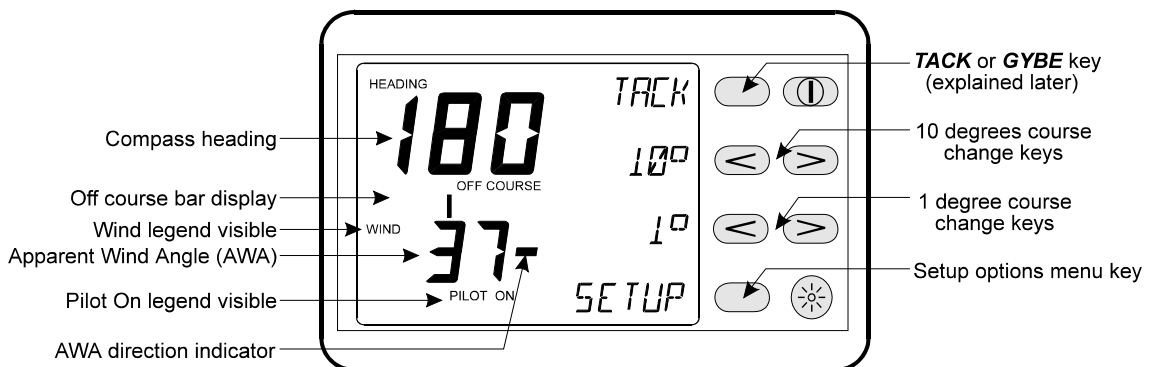

2.4.5 Dis-engaging the Autopilot

- (1) At any Autopilot Display press the **Red Off Key**. The Autopilot disengages and returns to manual steering.
- (2) At the Hand-held Controller press the **Red Off Key**. The Autopilot disengages and returns to manual steering.

Notes

1. When the Autopilot System is steering to wind, course changes are effected by changing the 'target' wind angle using the **10°** and **1°** Keys. The Autopilot calculates the course required to maintain the new 'target' wind angle.
2. The Autopilot Wind mode does not have a course memory so temporary course changes (dodges) are not possible. To return to a previous course the reciprocal course changes must be entered.

2.4.6 Steer to Wind Adjustments

- (a) **Fine Adjustments** - At any Autopilot Display press the **<** Key next to the **1°** legend to change the Autopilot 'target' wind angle by **1°** to port, and the **>** Key to change **1°** to starboard.

At the Hand-held Controller, press the **1°** Keys left and right to change the Autopilot 'target' wind angle to port or starboard by **1°**.

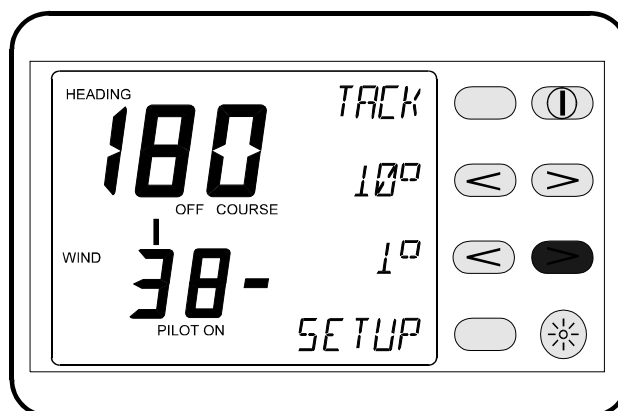

USER TIPS

Multiple key operations are added together to give the required course change, e.g. for a **1°** course change press the **1°** button.

Multiple key operations are added together to give the required wind angle change, e.g. for a 5° 'target' wind angle change press the 1° button 5 times.

(b) **Coarse Adjustments** - At any Autopilot Display press the < Key next to the 10° and 1° legends to change the Autopilot 'target' wind angle by 11° to port and the > Key to change 11° to starboard. At the Hand-held Controller press the 10° and 1° Keys to change the Autopilot 'target' wind angle to port or starboard by 11°.

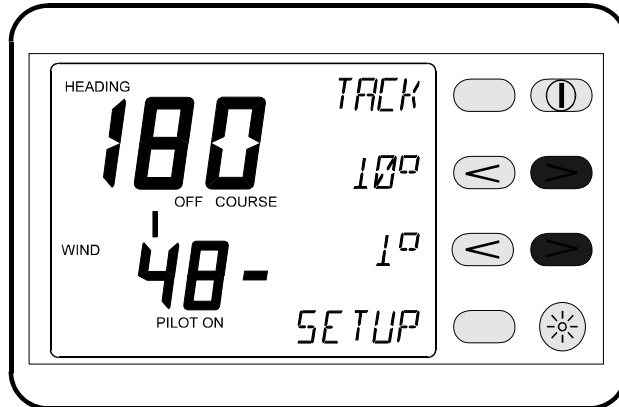

USER TIP

Multiple key operations are added together to give the required course change, e.g. for an 11° course change press the 10° + 1° button.

2.4.7 Pre-Setting the Wind Angle

When the boat is steered to a course and the Autopilot is then engaged, the Wind Angle is approximate. When a specific Wind Angle is required, this angle can be set up before engaging the Autopilot.

(1) At the Autopilot Display and with Autopilot in Standby press the key next to the **ANGLE** legend to display the Wind Angle Pre-setting Menu.

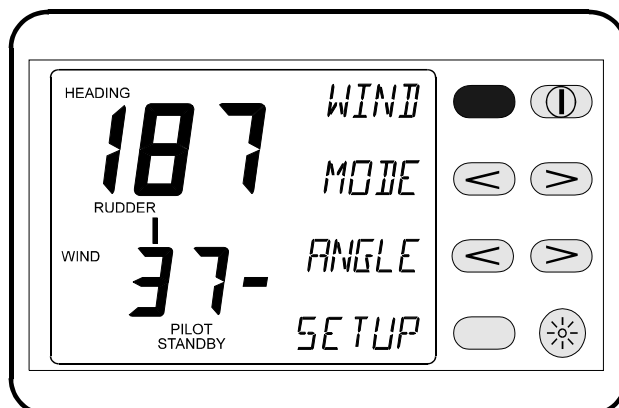

(2) Press the < > Keys next to the <<>> legend to alter the wind angle displayed on the lower digits.

(3) Press the key next to the **WIND** legend to engage the Autopilot on the User Defined Wind Angle. The boat will now steer to the User pre-set wind angle.

2.4.8 Auto Tack

When engaged in the Wind mode the Autopilot Computer calculates the True Wind Angle (TWA), thus enabling the Autopilot to indicate when it is possible to execute a Autopilot controlled tack. When the **Tack** Key is pressed the boat will be steered on the same User Defined Wind Angle but on the opposite tack.

The Autopilot software steers the boat through the wind, calculates a new 'target' wind angle and adds 5° to force the boat to bear away to ensure a fast pick up of speed. When the boat approaches the modified wind angle, the Autopilot alters course to sail to the original wind angle.

When the TWA is in the range of **-90° to +90°**, the boat is sailing in the tack zone. When **TACK** is indicated on any Autopilot Display:

(1) Press the key next to the **TACK** legend to execute an auto tack.

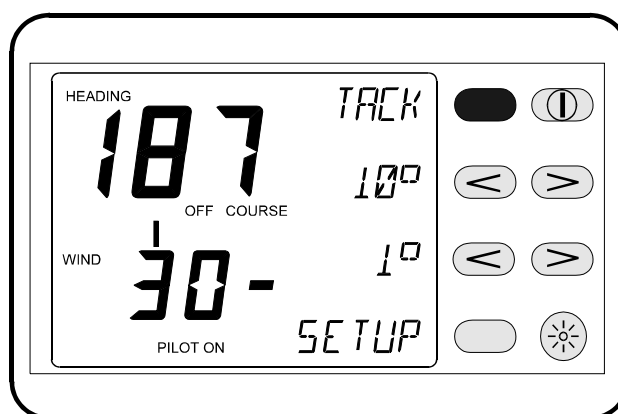

(2) At the Hand-held Controller press both the **10°** Keys simultaneously to execute an auto tack when the boat is in the tack zone.

The boat will tack as described previously on the opposite tack.

2.4.9 Auto Gybe

The Autopilot is also able to indicate when it is possible to execute a Autopilot controlled gybe. When the **Gybe** Key is pressed the boat will be steered on to exactly the same Target AWA, but on the opposite tack.

The Autopilot software controls the steering so that the wind slowly passes astern of the boat. This ensures the boom and sails are safely transferred to the opposite tack.

2.4.10 Gybe Zone

When the TWA is in the range -120° to $+120^{\circ}$ the boat is sailing in the gybe zone.

2.4.11 Using the Gybe Key

At any Autopilot Display, when in the gybe zone, the Autopilot Display will show **GYBE**. Press the key next to the **GYBE** legend to execute an auto gybe sequence.

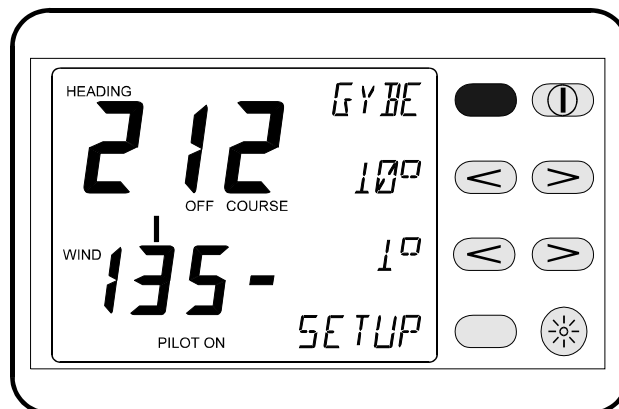

2.5 STEER TO WAYPOINT

Notes

Before using Steer to Waypoint, check the following points:

- (1) The position fixer has a compatible NMEA 0183 interface set-up in accordance with the manufacturer's instructions.

(2) The appropriate NMEA sentences are selected and set to be transmitted. The minimum data requirement is XTE (cross track error); however, XTE and Bearing to Waypoint give the best steering performance. For Autopilot operation select any of the following: RMB (best option), XTE, APA, or APB together with BWR or BWC.

(3) The position fixer is switched ON and has the correct current position.

(4) The signal and noise levels are within the manufacturer's recommended limits.

(5) The Waypoints have been entered correctly, and the Waypoint arrival alarm is switched ON.

(6) If using Waypoints in a route or sail plan (cruise plan), the Waypoints have been entered correctly and in the correct order, the direction of the route has been selected and the route is enabled.

2.5.1 Steer to Waypoint Introduction

This mode of steering is available to both sail and powerboats. It is also available for Autopilot Systems that are using either a Hydra or Hercules Instrument System, interfaced with a compatible position-fixing device using NMEA 0183 protocols.

The position fixer can be a GPS (Global Positioning System) or Loran-C receiver; which in turn could be interfaced with a chart plotter.

When engaged in **WAYPT** mode the Autopilot will steer a course using Waypoint data from the position fixer or plotter programmed with the Waypoint positions.

It is important to remember that when the Autopilot is steering to a Waypoint using NMEA data, any erratic data or positional errors generated by the position fixer will be transferred to the Autopilot via the NMEA interface and the Instrument System. Position fixer errors can be due to many causes including: poor reception, bad satellite constellation, radio beacon chain transitions, local geography (e.g. in a marina) and high power transmitters.

USER TIP

Position fixer errors can cause steering inaccuracy. Always maintain a log and position plot on an up-to-date chart. Also, remember to check that the Autopilot course (Waypoint to Waypoint) will steer the boat clear of any obstacles, taking into account the effects of tide.

2.5.2 Selecting the Waypoint Mode

At the Autopilot Display, press the key next to the **MODE** legend until **WAYPT** appears on the top line.

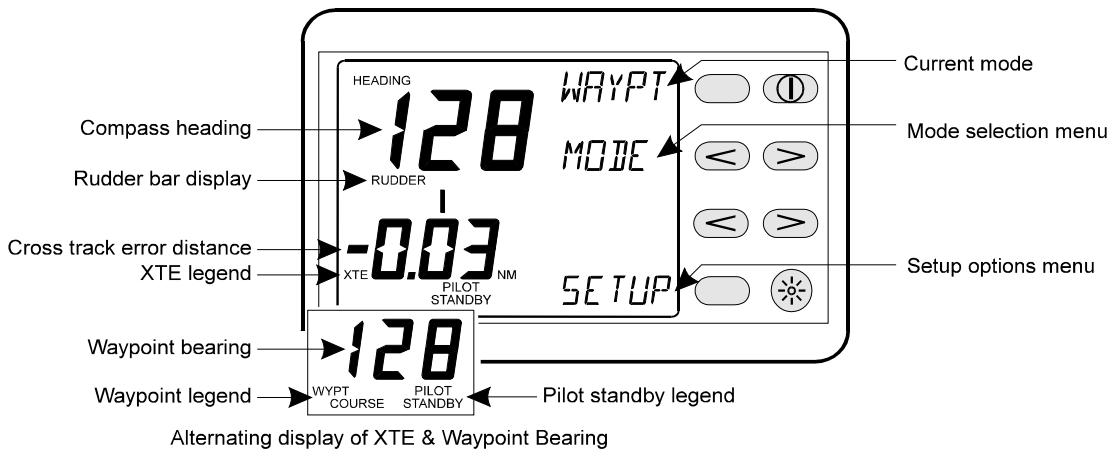

2.5.3 Engaging the Autopilot

Note

Before pressing the **Waypoint** Key steer the boat manually until the XTE distance is less than 0.03 NM and the heading is close to the Waypoint Bearing (Waypt Course) as shown on the Autopilot Display.

(1) At any Autopilot Display, press the key next to the **WAYPT** legend to engage the Autopilot.

(2) Press the **Auto/Resume** Key to engage the Autopilot from the Hand-held Controller.

Note

If XTE is more than 0.03 NM when the Autopilot is engaged in Steer to Waypoint mode, the course will be altered by up to 30° to bring the boat back onto track.

2.5.4 Dis-engaging the Autopilot

(1) At the Autopilot Display press the **Red Off Key**. The Autopilot immediately disengages and returns to manual steering.

(2) At the Hand-held Controller press the **Red Off Key**. The Autopilot immediately disengages and returns to manual steering.

2.5.5 Changing the Autopilot Course

(1) At the Autopilot Display press the **>** Key next to the **10°** legend to change the Autopilot course to starboard by 10°. The Autopilot previous course is stored in the course memory and the **LAST** legend is displayed.

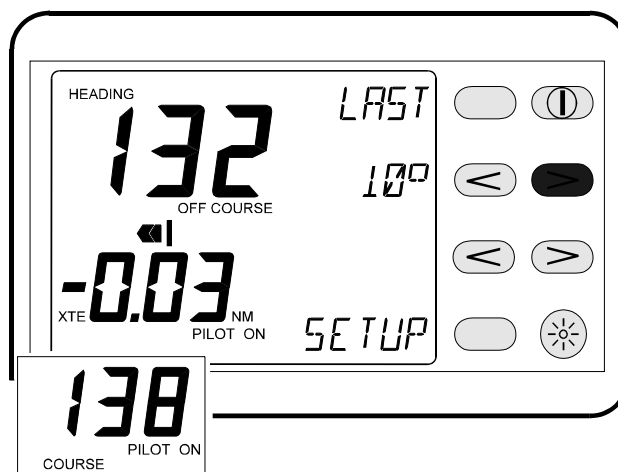

Alternating display of XTE & the 'Dodged' Pilot Course

(2) Press the **<** Key next to the **10°** legend to change the Autopilot course to port. The Autopilot previous course is stored in the course memory and the **LAST** legend is displayed.

(3) At the Hand-held Controller, press the **10°** Keys to change the Autopilot course to port or starboard 10°.

Note

The **1°** Keys do not function in the Waypoint mode.

USER TIP

Multiple key operations are added together to give the required course change, e.g. for a 20° course change press the **10°** Keys twice.

2.5.6 Returning to Original Course

(1) At the Autopilot Display, press the key next to the **LAST** legend to resume the last course.

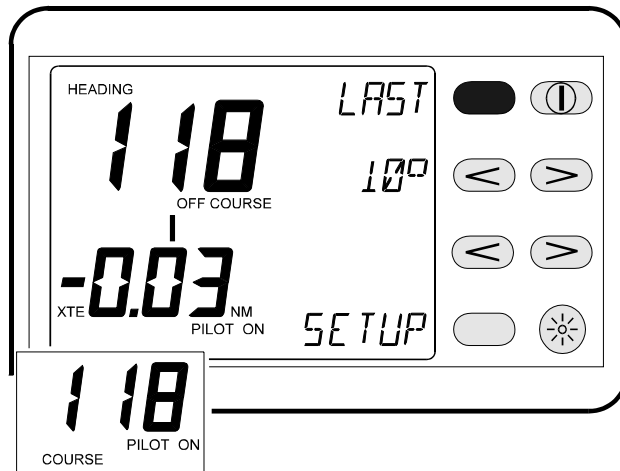

(2) At the Hand-held Controller press the **Auto/Resume** Key to return to the original course.

2.5.7 Waypoint Arrival Next Leg

Many position fixers automatically switch to the next leg of a sail plan when a programmed Waypoint is reached. The Autopilot will not steer the boat to the next leg but displays a prompt to the helmsman when the Waypoint is reached. The display shows **NEXT** legend next to the top key.

At any Autopilot display, press the key next to the **NEXT** legend to instruct the Autopilot to steer on the next leg of the sail plan.

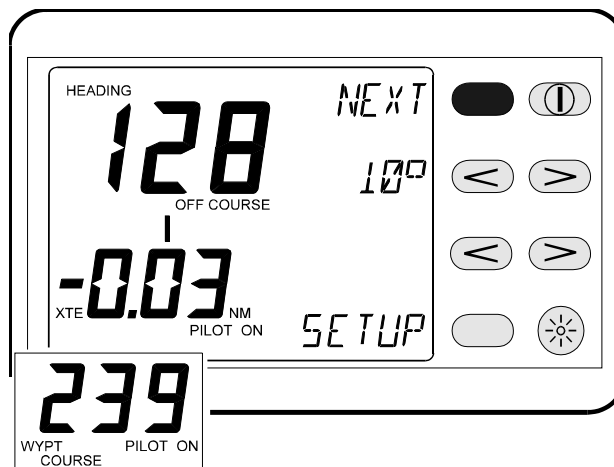

Alternating display of XTE & Next Waypoint Bearing

USER TIP

Allow a time margin for the next Waypoint bearing to stabilise before pressing the next key.

Note

The Bearing to Waypoint must be supplied via the NMEA interface for this function to operate; i.e. use one of the following NMEA sentences: APB, BWC, BWR, and RMB.

2.6 POWER STEER

2.6.1 Introduction

Power steer is available with all Autopilot configurations for sailboats and powerboats, and allows the helmsman to directly control the boat's rudder by either the Autopilot Display Unit keys or the Hand-held Controller. When in Power Steer mode, the Autopilot control software is by-passed and the key operations directly control the rudder drive unit.

USER TIP

Power steer can be used in an emergency if the normal manual steering became defective.

2.6.2 Selecting Power Steer Mode

At any Autopilot Display, press the key next to the **MODE** legend until **POWER** appears on the top line.

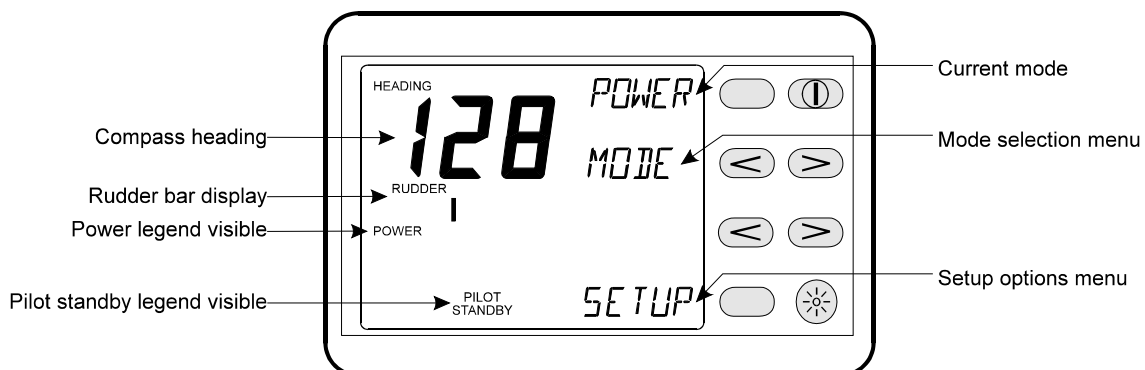

2.6.3 Engaging the Autopilot

Note

The rudder should be in the amidships position (or the position at which the boat steers a straight course) before the **Power** Key is pressed.

(1) At any Autopilot Display, press the key next to the **POWER** legend to engage the Autopilot.

(2) At the Hand-held Controller press the **Auto/Resume** Key to engage the Autopilot with the Hand-held Controller.

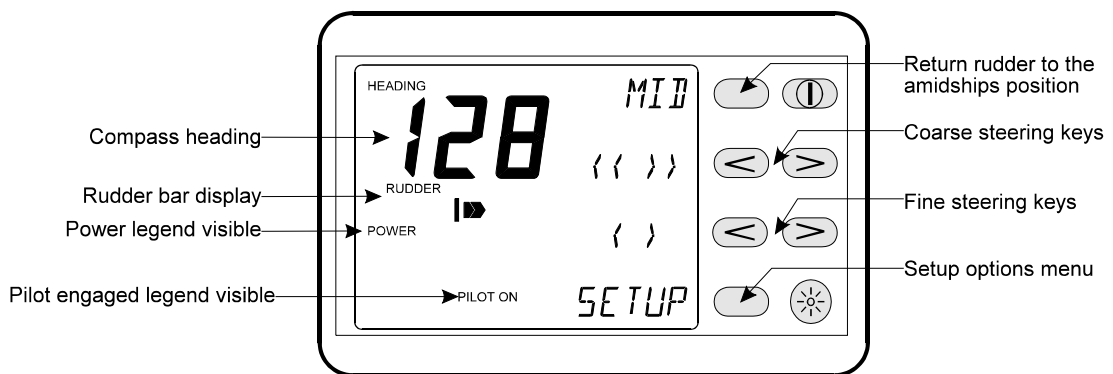

2.6.4 Dis-engaging the Autopilot

(1) At the Autopilot Display press the **Red Off** Key. The Autopilot immediately disengages and returns to manual steering.

(2) At the Hand-held Controller press the **Red Off** Key. The Autopilot immediately disengages and returns to manual steering.

2.6.5 Fine Rudder Adjustments

(1) At the Autopilot Display press the **>** Key next to the legend **< >** to move the rudder to starboard in steps of 0.6° .

(2) Press the **<** Key next to the legend **< >** to move the rudder to port in steps of 0.6° .

(3) At the Hand-held Controller press the **1°** Keys to move the rudder to port or starboard in steps of 0.6° .

USER TIP

Multiple operations of the keys are added together to give the required rudder change.

2.6.6 Coarse Rudder Changes

(1) At the Autopilot Display press the < > Keys next to the << >> legend to move the rudder to port or starboard in steps of 3°.

(2) At the Hand-held Controller press the 10° Keys to move the rudder to port or starboard by 3°.

USER TIP

Multiple operations of the keys are added together to give the required change

2.6.7 Mid Key

Note

When the **MID** Key is pressed, the rudder will return to the position set before **POWER** steer was engaged. If the rudder was set at the amidships position then the **MID** Key will return the rudder to that position.

(1) At any Autopilot Display press the key next to the **MID** legend to return the rudder to the amidships position.

(2) At the Hand-held Controller press the **Auto/Resume** Key to return the rudder to the amidships position.

2.7 JOYSTICK STEERING

2.7.1 Introduction to Joystick Steering

The joystick allows direct control of the rudder via the Autopilot Computer for quick and responsive steering. Joystick steering is engaged and disengaged with the separate Red Joystick Button. The lever can only be moved to port or starboard. Refer to Paragraph 2.8.12 to enable joystick steering.

There are two joystick steering options available to the helmsman:

(a) **Normal Steering (Norm)** - The rudder moves in the direction of the joystick. When the joystick returns to the central position the rudder movement stops. The greater the movement of the joystick, the faster the response of the rudder.

(b) **Proportional Steering (Prop)** - The position of the rudder follows the position of the joystick. When the joystick returns to the central position the rudder returns to its initial position.

2.7.2 Engaging the Autopilot

Turn the wheel until the rudder is in the amidships position, and then press the separate Red Joystick Button.

Notes

1. Joystick mode can only be engaged by using the Joystick Button.
2. When the Autopilot is engaged in Joystick mode the rudder position (at the moment of engaging) will be the central (null) position of the joystick. Ensure that the rudder is at the amidships position before engaging the Autopilot.

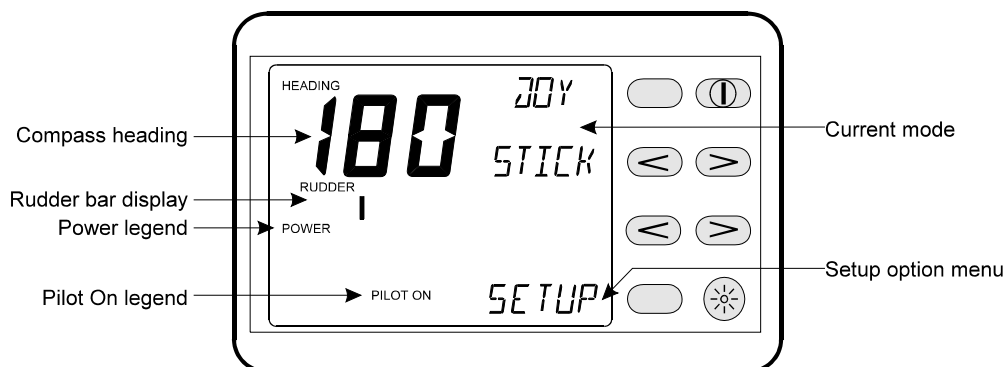

USER TIP

To counteract any external influences on the steering, e.g. wind and tide, steer the boat on to a straight and steady course before engaging the Autopilot. This is only true so long as the same course is maintained.

2.7.3 Dis-engaging the Autopilot

(1) To dis-engage the Autopilot when in Joystick mode press the Joystick Button and the boat will return to manual steering.

(2) At the Autopilot Display press the **Red Off Key**. The Autopilot disengages and returns to manual steering.

(3) At the Hand-held Controller press the **Red Off Key**. The Autopilot disengages and returns to manual steering.

Note

The Autopilot can be immediately disengaged and the steering returned to manual control by pressing the **Red Off Key** on any Autopilot Display or Hand-held Controller.

2.7.4 Normal Steering

The rudder moves in the same direction as the joystick and the display indicates the direction. When the spring-loaded joystick is released, it returns to the central position and the rudder movement stops and remains at this position. The speed of rudder response is proportional to the joystick displacement.

2.7.5 Proportional Steering

When proportional steering is used, the rudder follows the rate and direction of the joystick movement from hard to port to hard to starboard. When the joystick is in the centre position, the rudder is amidships. The Autopilot LCD rudder bar display indicates the rudder position.

2.8 SET-UP OPTIONS

The Hydra and Hercules Autopilots have eleven common set-up options, however if a Halcyon Gyro Stabilised Compass and its associated processor are installed into the Autopilot system, additional set-up options become available. All set-up options are used to change and select the operating modes, steering characteristics and alarms of the Autopilot System, whether it is fitted to a powerboat or a sailing boat.

The Set-up Menu is accessed by pressing the key next to the **SETUP** legend on any Autopilot Display Unit, and is available when the Autopilot is either engaged or disengaged in any steering mode.

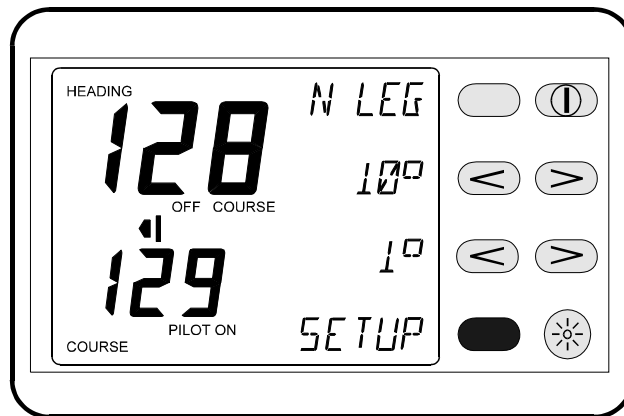

When the Set-up Menu is displayed, the set-up options can be listed, changed and entered in to the Autopilot memory. The diagram below shows a typical display when using the Set-up Menu.

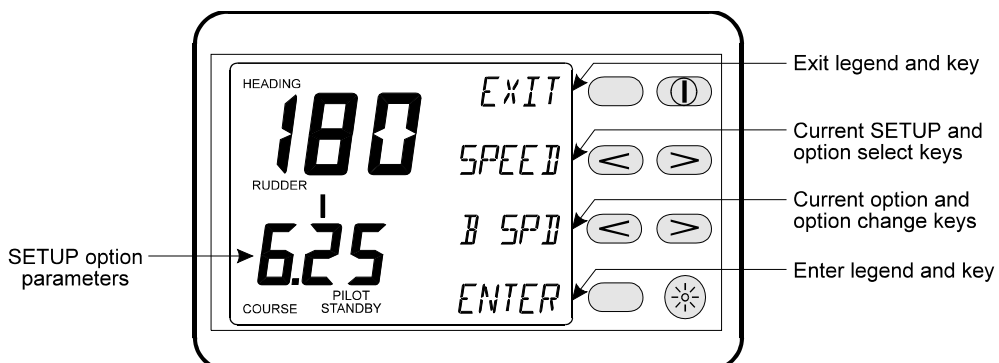

To exit the Set-up Menu following completion of the set-up procedures described in the Paragraphs 2.8.1 to 2.8.12 press the key next to the **EXIT** legend. The LCD will return to the previous display before selection of the Set-up Menu.

2.8.1 Manual Response Set-Up (RESP)

The **RESP** set-up controls the response of the steering. Different selections are available dependent on whether the heading source is from the Halcyon 2000 Compass or a B&G Halcyon Gyro compass.

Response Settings with Halcyon 2000 Compass

- (a) NORM - Normal course keeping and rudder response (default).
- (b) ECON - Economy: the rudder movement is limited, this reduces the overall power consumption of the Autopilot System, however there is a slight reduction in course keeping.
- (c) DWIND - Down-wind; the response is changed for down-wind steering by applying the rudder more quickly. This allows the Autopilot to hold a better course in adverse conditions, such as sailing down-wind or with a quartering sea. However there is an increase in the power consumption.

Response Settings with B&G Halcyon Gyro

- (a) NORM - Normal course keeping and rudder response (default).
- (b) ECON - Economy: the rudder movement is limited, this reduces the overall power consumption of the Autopilot System, however there is a slight reduction in course keeping.
- (c) PERF 1 to 4 – The PERF function allows for a manual increase or decrease of steering response by using the UP/DOWN arrow keys.

Of the four PERF settings, PERF 1 is the minimum setting and PERF 4 is the maximum.

To set-up **RESP**:

- (1) Press the key shown until **RESP** is displayed.

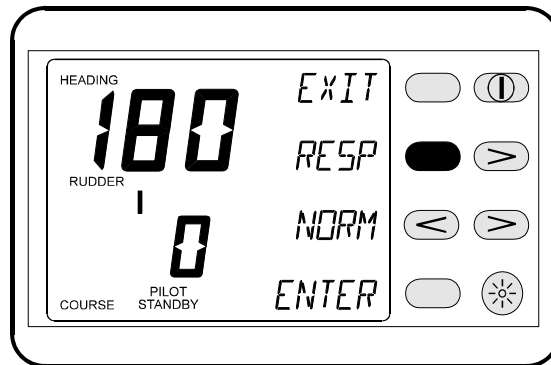

- (2) Press the key shown to scroll through the list of **RESP** options.

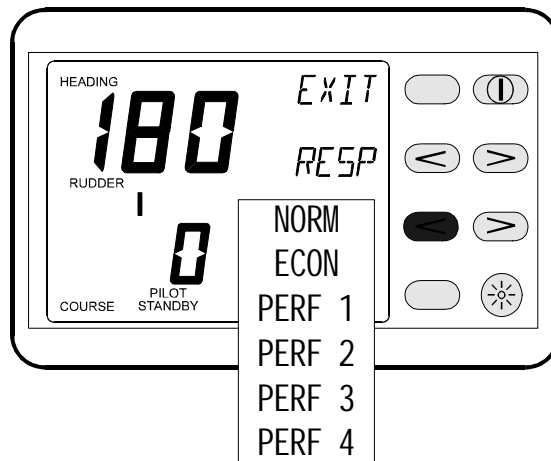

- (3) When the required response is displayed press the key next to the **ENTER** legend. Continue with set-up or press the key next to the **EXIT** legend to return to the normal Autopilot display.

2.8.2 Mode Set-Up (MODE)

The **MODE** set-up allows the steering mode to be changed while the Autopilot is engaged. Dependent upon the Autopilot and Instrument System configuration fitted, there are four options available:

- (a) COMP - Steer to Compass.
- (b) WIND - Steer to Wind.
- (c) OPT W - Steer to Optimum Wind (Hercules Autopilot).
- (d) WAYPT - Steer to Waypoint.

To set-up **MODE**:

- (1) Press the key shown until desired **MODE** is displayed.

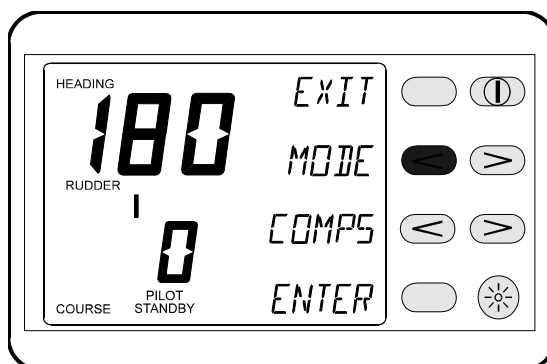

- (2) Press the key shown to scroll through the list of **MODE** options.

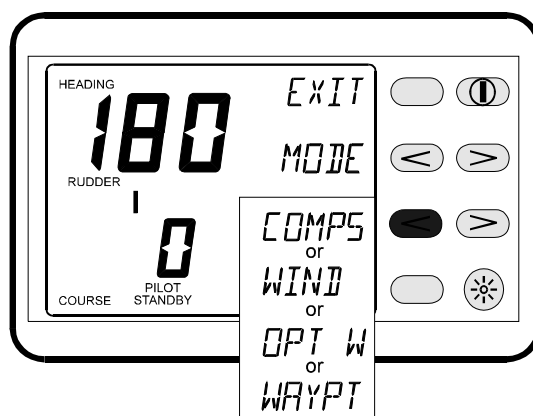

- (2) When the required mode is displayed press the key next to the **ENTER** legend. Continue with set-up or press the key next to the **EXIT** legend to return to the normal Autopilot display.

2.8.3 Automatic Response Set-Up (ARESP)

This option is only available if a Halcyon Gyro Stabilised Compass is fitted. The **ARESP** set-up enables the Autopilot to automatically alter the response of the steering to be selected. There are four options available:

- (a) OFF – In this mode the Autopilot will remain in the response mode selected in section 2.8.1.
- (b) ECON – Economy: in this mode, the Autopilot will need to sense large environmental changes before it will increase its response rate.

(c) **NORM** – Normal: in this mode, the Autopilot will respond to moderate changes in environmental state before altering its response rate.

(d) **SPORT** – in this mode, the Autopilot will be most sensitive to changing conditions and will automatically increase its response rate to counter environmental changes.

The Automatic Response setting will not drop below the manual response setting discussed in section 2.8.1. When the conditions have improved, the Autopilot will automatically return to the manual response setting.

To set-up **ARESP**:

(3) Press the key shown until **ARESP** is displayed.

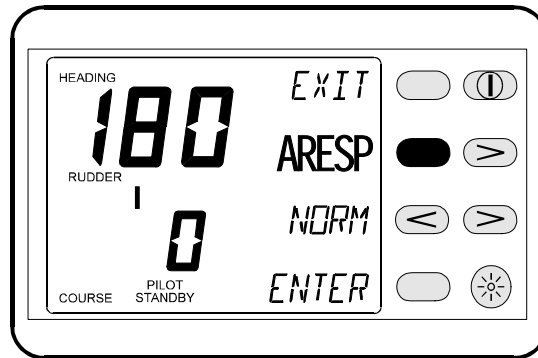

(2) Press the key shown to scroll through the list of **RESP** options.

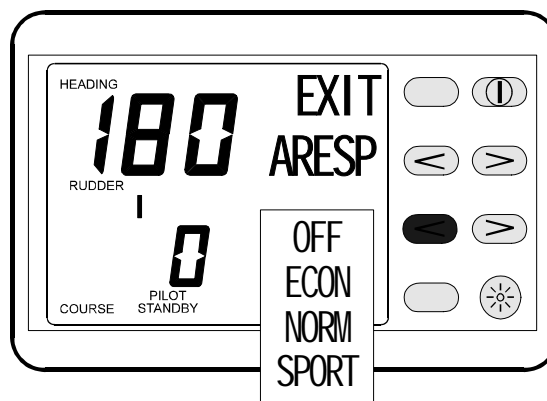

(3) When the required response is displayed press the key next to the **ENTER** legend. Continue with set-up or press the key next to the **EXIT** legend to return to the normal Autopilot display.

2.8.4 Recovery Mode Sensitivity (RECOV)

This function is only available when a Halcyon Gyro Stabilised Compass is connected to the system.

Recovery Mode allows the user to select the sensitivity that allows the Autopilot to react to unexpected events, for example sudden wave or wind shifts. This function allows the Autopilot to instantaneously increase the steering response to its maximum setting (PERF 4), and make a rapid recovery.

The Recovery Mode will automatically switch off after 15 seconds or when the heading error has been corrected. The Autopilot will then resume the previous response setting and continue normal operation.

There are four options available dependent on the severity of the prevailing conditions:

- (a) Off - the Recovery Mode function is switched off.
- (b) WIDE - in this setting, the Autopilot is least sensitive to sudden course changes.
- (c) MED - in this setting, the Autopilot is configured to the medium value when correcting sudden course changes.
- (d) NARR - in this setting, the Autopilot is most sensitive to sudden course changes.

2.8.5 Speed Set-Up (SPEED)

The **SPEED** set-up allows the source used for speed data to be selected. There are three options available:

- (a) B SPD - Boat speed from a speed sensor (default).
- (b) SOG - Speed Over Ground from NMEA device.
- (c) F SPD - Fixed speed entered by the user.

To set-up **SPEED**:

- (1) Press the key shown until **SPEED** is displayed.

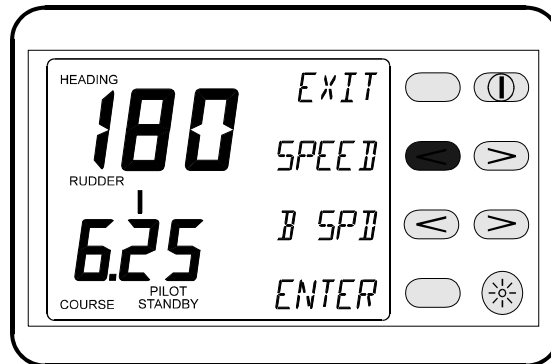

- (2) Press the key shown to scroll through the list of **SPEED** options.

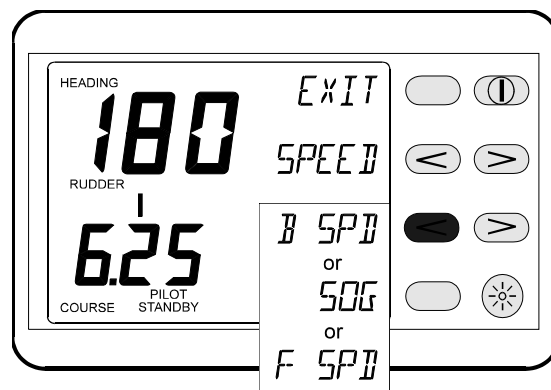

Note

SOG will only be displayed when the Autopilot is receiving valid NMEA data from a position fixer. The default set-up is **B SPD**.

(3) When B SPD or SOG are selected, press the key next to the **ENTER** legend. Continue with set-up or press the key next to the **EXIT** legend to return to the normal Autopilot display.

(4) When F SPD is selected press the key next to the **ENTER** legend and proceed with steps (5) and (6) to set the fixed speed value.

(5) Use the keys shown to adjust the value in increments of 0.5 to the desired fixed speed within the range 0.5 to 60.0.

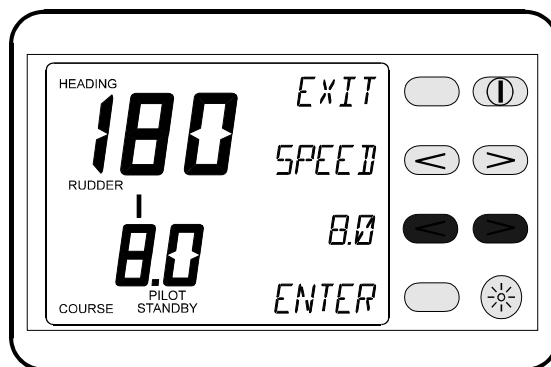

Note

The default value for a sailboat is 8.0 knots and 25.0 knots for a powerboat.

(6) Press the key next to the **ENTER** legend to set the fixed speed value. Continue with set-up or press the key next to the **EXIT** legend to return to the normal Autopilot display.

2.8.6 Off Course Set-Up (OFF C)

The **OFF C** set-up selects the Autopilot Display to show either off course or rudder angle when the Autopilot is engaged in **COMP**, **WIND**, **OPT W** or **WAYPT** modes of steering. There are two options available:

- (a) ON - The bar display shows OFF COURSE (default).
- (b) OFF - The bar display shows RUDDER.

To set-up **OFF C**:

(1) Press the key shown until **OFF C** is displayed.

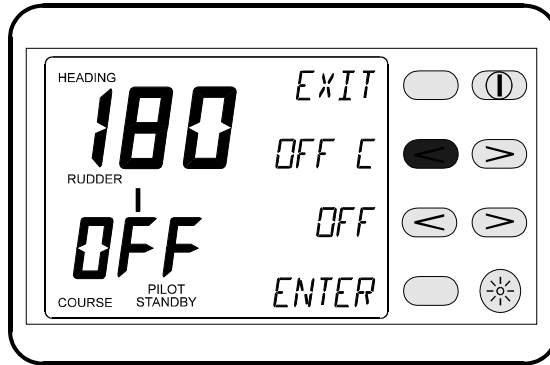

(2) Press the key shown to select the display function of the bar display when the Autopilot is engaged.

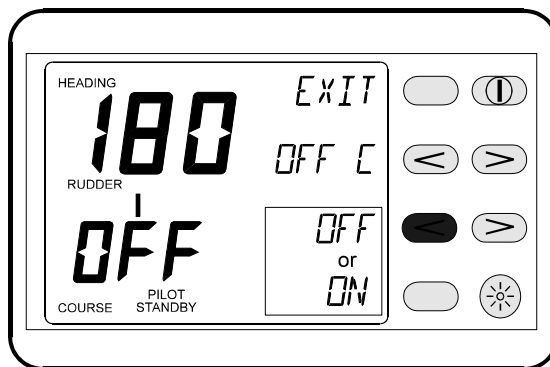

(3) When the required display function is displayed press the key next to the **ENTER** legend. Continue with set-up or press the key next to the **EXIT** legend to return to the normal Autopilot display.

2.8.7 Compass Damping Set-Up (C DMP)

The **C DMP** set-up is the amount of damping (response to change) applied to the displayed value of compass heading (top digits of Autopilot Display Unit LCD) and can be set in the range 0 to 99 seconds. The default setting is four.

Note

This does not affect the response of the Autopilot.

To set-up **C DMP**:

(1) Press the key shown until **C DMP** is displayed.

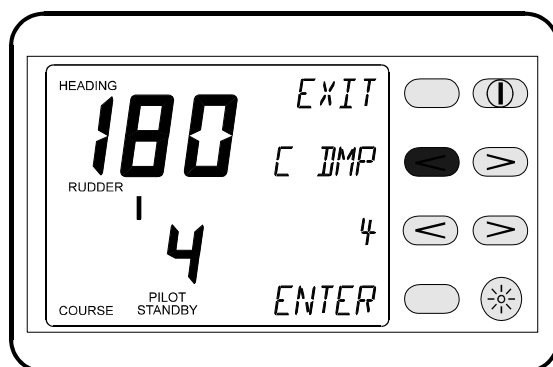

(2) Use the keys shown to adjust the value within the range 0 to 99 seconds.

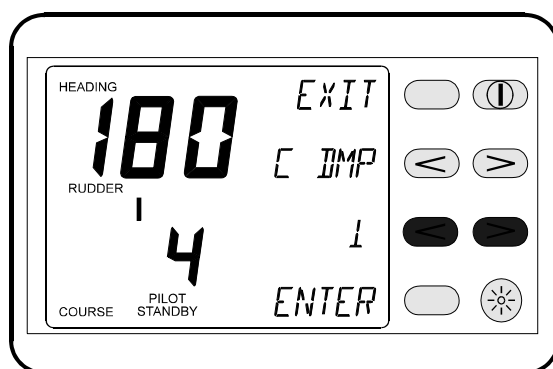

(3) When the required value is displayed press the key next to the **ENTER** legend. Continue with set-up or press the key next to the **EXIT** legend to return to the normal Autopilot display.

2.8.8 NMEA Source Set-Up (N SRC)

The **N SRC** set-up selects the source of NMEA data when more than one NMEA position fixer is connected to the Hydra or Hercules Instrument System. The selections displayed depend upon the NMEA data that is being received by the instrument system. The options are listed below:

- (a) AT 0 - Automatic selection (default).
- (b) GP - GPS data.
- (c) LC - Loran-C data.
- (d) II - Integrated Instrument data.

Note

When more than one of the same type of NMEA position fixer is connected, i.e. two GPS receivers, then the number following the device identifier, e.g. **GP 96**, determines which GPS is supplying the NMEA data.

To set-up **N SRC**:

- (1) Press the key shown until **N SRC** is displayed.

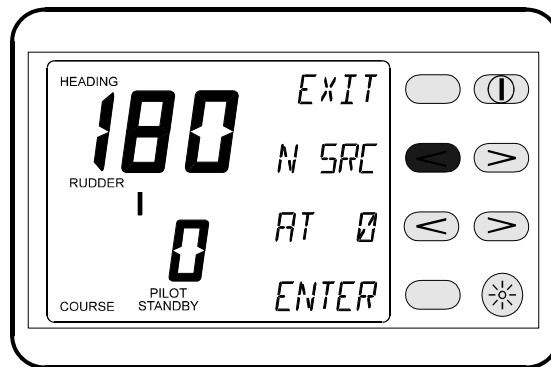

- (2) Press the key shown to scroll through the list of available **N SRC** options.

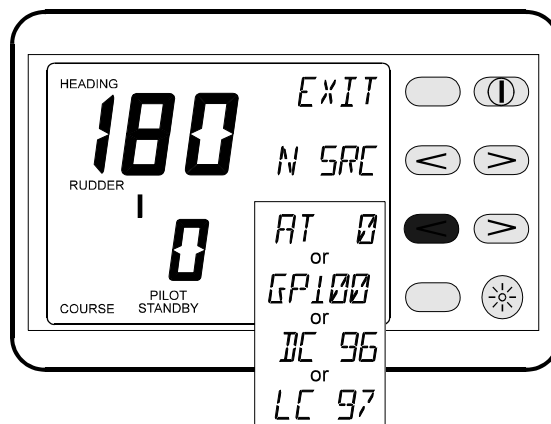

- (3) When the required setting is displayed press the key next to the **ENTER** legend. Continue with set-up or press the key next to the **EXIT** legend to return to the normal Autopilot display.

2.8.9 Course Alarm Set-Up (CRS A)

The **CRS A** set-up enables the Course Alarm facility. The Autopilot will sound an alarm (if an audible alarm is fitted to the instrument system) and all the system displays flash a warning when the Autopilot off course error is greater than the value set. The alarm is temporarily disabled while the boat is turning. There are two selections:

- (a) OFF - The alarm is disabled (default).
- (b) 1 to 180 - A number is set in degrees. The alarm is enabled when the value is entered.

To set-up **CRS A**:

- (1) Press the key shown until **CRS A** is displayed.

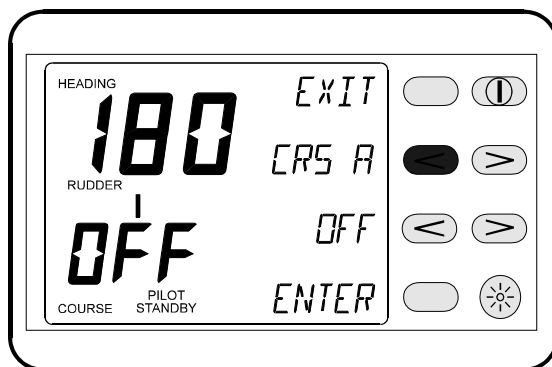

- (2) Use the keys shown to adjust the value within the range OFF to 180°.

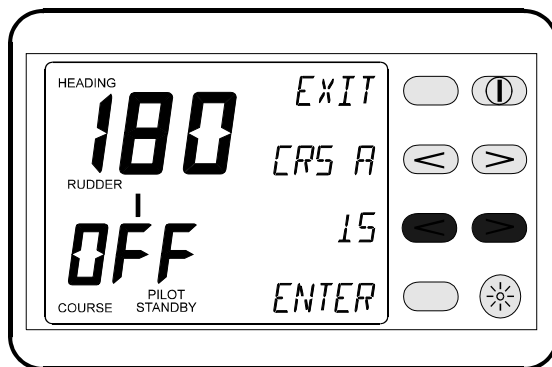

- (3) When the required value is displayed press the key next to the **ENTER** legend. Continue with set-up or press the key next to the **EXIT** legend to return to the normal Autopilot display.

2.8.10 Watch Alarm Set-Up (WATCH)

The **WATCH** set-up enables the watch alarm facility. The Autopilot will sound an alarm (if an audible alarm is fitted to the Instrument System) and cause all the system displays to flash a warning at a pre-set time interval to keep the helmsman and crew alert. There are two selections:

- (a) OFF - The alarm is disabled (default).
- (b) 1 to 360 - A number is set in minutes. The alarm is enabled when the value is entered.

To set-up **WATCH**:

- (1) Press the key shown until **WATCH** is displayed.

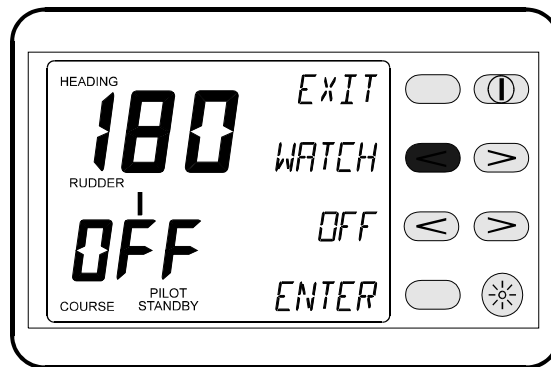

- (2) Use the keys shown to adjust the value within the range OFF to 360 minutes.

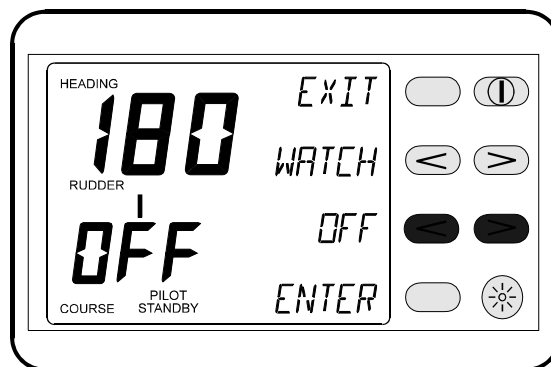

- (3) When the required value is displayed press the key next to the **ENTER** legend. Continue with set-up or press the key next to the **EXIT** legend to return to the normal Autopilot display.

2.8.11 Back Lighting Set-Up (LIGHT)

The **LIGHT** set-up alters the LCD backlighting colour for all Autopilot Displays and FFDs connected to the system. There are two selections:

- (a) RED (default).
- (b) GREEN.

To set-up **LIGHT**:

- (1) Press the key shown until **LIGHT** is displayed.

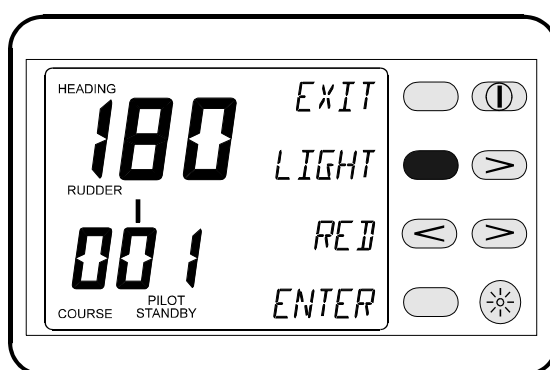

- (2) Press the key shown to select either **RED** or **GREEN**.

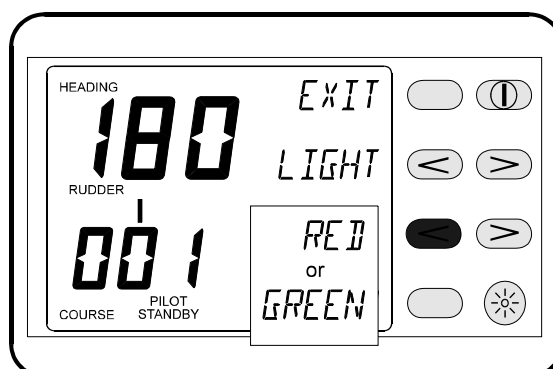

- (3) When the required setting is displayed press the key next to the **ENTER** legend. Continue with set-up or press the key next to the **EXIT** legend to return to the normal Autopilot display.

2.8.12 Joystick Set-Up (JYSTK)

The **JYSTK** set-up selects the joystick steering, see the joystick section of this manual for details about the different steering modes. There are two selections:

- (a) NORM - Normal steering mode (default).
- (b) PROP - Proportional steering mode.

To set-up **JYSTK**:

- (1) Press the key shown until **JYSTK** is displayed.

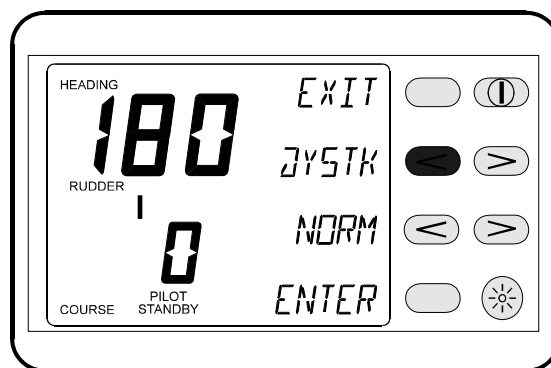

- (2) Press the key shown to select either **NORM** or **PROP**.

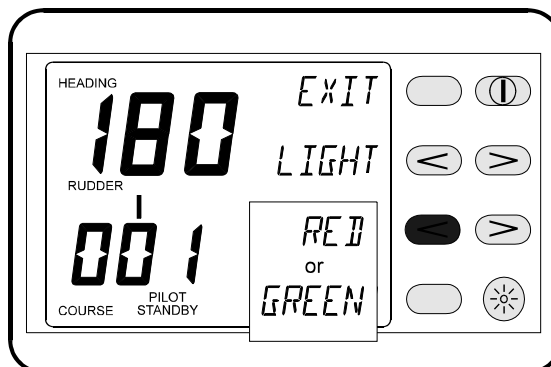

- (3) When the required setting is displayed press the key next to the **ENTER** legend. Continue with set-up or press the key next to the **EXIT** legend to return to the normal Autopilot display.

2.9 AUTOPILOT INFORMATION ON FFD

The Hydra or Hercules Instrument System FFD (full function display) can be configured to display a limited range of Autopilot information. This information is accessed via the Autopilot Menu that only appears when a Autopilot is connected. The following information is available on any system FFD.

2.9.1 Autopilot Course (PLT CRSE °M)

The FFD can display the Autopilot course in degrees magnetic. The displayed digits are the same as the lower digits of the Autopilot Display Unit. When the Autopilot is engaged the **AUTOPILOT ON** legend appears on the FFD. When the Autopilot is disengaged, the FFD will show **OFF** where Autopilot information is normally displayed.

2.9.2 Rudder Angle (RUDDER °)

The rudder angle can be displayed when the Autopilot is engaged or disengaged; this is particularly useful for manoeuvring. The angle is shown in degrees port or starboard of the amidships position, indicated by two bars to the left or right of the digits.

2.9.3 Off Course Error (OFF CRSE °)

The digits display the difference between the compass heading and the Autopilot course in degrees. A "dog-leg" symbol indicates the direction to steer to correct the course error. When the Autopilot is disengaged, the display will show **OFF**.

2.9.4 Man Overboard Facility (MAN OVER)

The Man Overboard Button (MOB) is an optional extra that when fitted can be used to activate the MOB procedure. This can be used as an aid in recovering personnel or equipment lost overboard.

Under normal operating conditions, the display will show a **NO** legend. When activated the FFD shows an alternating display of Bearing and Distance to the MOB.

2.9.5 Autopilot Faults and Errors (PLT ERR)

The Autopilot is constantly self-checking for correct operation. If an error occurs or a parameter is outside the normal operating specification, then the FFD can display a number that relates to a fault. See Part 6 - Diagnostic Data.

2.10 MAN OVERBOARD FACILITY

The Man Overboard Button (MOB) is an optional extra that activates the Autopilot's Man Overboard alarm procedure. The MOB can be used whether the Autopilot is engaged or disengaged.

The purpose of this feature is to aid in the recovery of crew or passengers lost overboard. By sending the bearing and distance to the Autopilot, the execution of a "Williamson Turn" can be achieved automatically. The boat is returned to the position at which the MOB was pressed.

2.10.1 Man Overboard Procedure

For this facility to operate there is a requirement to have a speed sensor input. User entered fixed speed or Speed Over Ground from a position fixer will not activate the MOB procedure.

Sailboats, because of the need to tack or gybe, must use Manual Recovery. The boat is steered back to the MOB position, following the bearing and distance displays, either manually or under Autopilot control.

Powerboat owners, however, can use the Autopilot for Automatic Recovery. The Autopilot will control the steering of the boat to execute a "Williamson Turn" and return the boat along the reciprocal course.

When the MOB is pressed, the Instrument System audible alarm will sound (if fitted), the LCDs will show the MOB message and if the back-lighting is ON, the colour will flash from red to green. Pressing the Enter Key twice on any Full Function Display silences the alarm.

The full procedures for Manual and Automatic Man Overboard Recovery are described overleaf. These procedures should be practised and explained to all crew and passengers on board the vessel. This practice could help to save a life.

2.10.2 Manual Recovery (All Boats)

(1) Press the MOB as soon as the person is lost overboard. The alarm will sound (if fitted) and the display will show the Man Overboard message. The Autopilot display and the FFDs will now show the bearing and distance to the person overboard. The bearing will be flashed three times and then the distance (in Nautical Miles) once only.

(2) Press the key next to the **MOB B** legend twice on any Autopilot display or the **Enter** Key on any FFD to acknowledge the man overboard. The displays will stop flashing and the audible alarm will be silenced.

(3) Maintain a lookout and keep visual contact with the person in the water. Steer the boat back to the person overboard following the bearing and distance displays. The boat can be steered using the course change buttons when the Autopilot is engaged, or press the **Red Off** Key to disengage the Autopilot and steer the boat manually. Recover the person overboard.

(4) To end the MOB sequence at any time press the key next to the **CANCL** on any Autopilot Display twice or press and hold the MOB for 5 seconds. The displays of bearing and distance are cancelled and the Autopilot will return to the normal (previous) setting.

2.10.3 Automatic Recovery (Power Only)

(1) Press the MOB as soon as the person is lost overboard. The alarm will sound and the display will show the Man Overboard message. The Autopilot display and the FFDs will now show the bearing and distance to the person overboard. The bearing will be flashed three times, then the distance (in NM) once.

(2) Press the key next to the **MOB B** legend twice on any Autopilot Display or the **Enter** Key on any FFD to acknowledge the man overboard. The displays will stop flashing and the audible alarm will be silenced.

(3) Maintain a lookout and keep visual contact with the person in the water. Reduce the boat speed to **LESS THAN** 8 knots. Ensure that the area is clear of other boats and obstacles.

(4) Press the MOB three times in quick succession to initiate an automatic recovery. The Autopilot will control the steering and execute a "Williamson Turn". Alternatively, press the **Red Off** Key to disengage the Autopilot and steer the boat manually. Recover the person overboard.

(5) To end the MOB sequence press the key next to the **CANCL** on any Autopilot Display twice or press and hold the MOB for 5 seconds. The displays of bearing and distance are cancelled and the Autopilot will return to the normal (previous) setting.

Intentionally Left Blank

PART 3 - COMMISSIONING AND CALIBRATION

CONTENTS

Para		Page
3.1	INTRODUCTION TO PILOT COMMISSIONING	3-3
3.1.1	h2000 Autopilot Commissioning	3-3
3.1.2	Autopilot Installation Check List	3-3
3.1.3	Parameters to be Set	3-6
3.2	COMMISSIONING MODE SELECTION	3-7
3.2.1	Entering Commissioning Mode	3-7
3.3	COMMISSIONING/CALIBRATION ALONGSIDE	3-8
3.3.1	Boat Type Selection (B TYPE)	3-8
3.3.2	Setting the Boat Type	3-8
3.3.3	Heading Source (Compass) H SRC	3-9
3.3.4	Setting the Heading Source Value	3-9
3.3.5	Heading Offset (Compass Alignment) H OFF	3-10
3.3.6	Adjusting the Heading Offset	3-10
3.3.7	Magnetic DIP Angle DIP	3-10
3.3.8	Setting the Magnetic DIP Value	3-10
3.3.9	Rudder Drive Type (Drive)	3-11
3.3.10	Setting the Drive Type	3-11
3.3.11	Setting the Rudder End Stops	3-12
3.3.12	Setting the Boat Length (B LEN)	3-15
3.4	SEA TRIAL COMMISSIONING/CALIBRATION	3-15
3.4.1	Introduction	3-15
3.4.2	Verify Rudder Power Drive	3-16
3.4.3	Selecting Power Steer Mode	3-17
3.4.4	Power Steer Check	3-17
3.4.5	Compass Swing Calibration	3-18
3.4.6	Calibrating the Autopilot Compass	3-18
3.4.7	Setting the Heading Offset Value (H Off)	3-19
3.4.8	Calibration of Speed Input (S CAL)	3-19
3.4.9	Setting the Speed Calibration Value	3-20
3.4.10	Rudder Gain (R GAN)	3-20
3.4.11	Checking Rudder Gain Learning	3-21
3.4.12	Setting the Rudder Gain Manually	3-21
3.4.13	Setting the Rudder Gain Value	3-22
3.4.14	Boat Lag Value	3-23
3.4.15	Checking the Boat Lag	3-23

CONTENTS (Contd.)

Para		Page
3.4.16	Setting the Boat Lag Value	3-24

ILLUSTRATIONS

Fig No		Page
3-1	Magnetic DIP Angle Corrections	3-11
3-2	Boat Lag Response	3-23

TABLES

Table No		Page
3.1	Compass Data	3-9
3.2	Rudder Gain Value	3-22
3.3	Boat Lag Value Table	3-24

PART 3 - COMMISSIONING AND CALIBRATION

3.1 INTRODUCTION TO AUTOPILOT COMMISSIONING

3.1.1 h2000 Autopilot Commissioning

Before the h2000 Autopilot can be used, it is necessary to carry out commissioning tests. This encompasses the setting and calibration of various parameters, installation and functional checks of the autopilot System equipment. These items are listed below in Paragraph 3.1.2.

The procedure for commissioning can be divided into two stages. The first stage is carried out alongside at the dock and the second stage is performed during the course of a sea trial. The order in which the commissioning procedures are carried out is not the order in which they appear when the keys are pressed. Press the function key until the required parameter is displayed.

This manual covers both the ACP 1 (25A) and ACP 2 (40A) Autopilot Systems.

3.1.2 Autopilot Installation Check List

The checklist below should be used before the commissioning of the autopilot to ensure that the entire system is functional before applying power.

Drive Unit and Steering System

- (1) Drive unit securely fixed to a rigid part of the boat structure.
- (2) Correct gauge of power cable has been selected.

Hydraulic Rams

- (1) Boat end stops must limit the rudder movement, not the stroke of the hydraulic ram.
- (2) Split pins and spacers that secure the ram to its mounting foot are secure.
- (3) Absence of oil leaks.
- (4) Correct diameter bolt in universal ball joint, correct size hole in tiller.

- (5) Ram free to move side to side and up and down.
- (6) Reservoir at highest point if ram split.

For Size Three Rams only:

- (7) The reservoir has been fixed to a bulkhead above the ram and pump.
- (8) The sealed reservoir transit cap has been replaced with the breather cap supplied.
- (9) The reservoir has been filled with the oil supplied.
- (10) The reservoir tap has been switched to the 'ON' position allowing the oil to flow between the reservoir and the pipe.

Note

The tap 'ON' position is in alignment with the pipe.

Hydraulic Pumps

- (1) A position should be chosen convenient for the steering system hydraulic delivery lines.
- (2) The site should be rigid and flat to prevent excess vibration.
- (3) Shielded from the direct effects of the elements.
- (4) Minimise the lengths of the hydraulic lines from the pump to the cylinder and where possible the pump motor supply cables.
- (5) Absence of oil leaks.
- (6) Absence of air in the hydraulic system.

Rotary Drives

- (1) No backlash or excessive slackness in chain.

Rudder Reference Installation

- (1) Base securely fixed to boat structure.
- (2) Arm securely fixed to boss.
- (3) Ball joint securely fixed to arm.

- (4) Linkage has not been over extended.
- (5) No slack or backlash in the linkage.
- (6) Linkage does not foul when rudder moved hard over to hard over.
- (7) Arm moves through at least 90° when rudder moved hard over to hard over (there must be at least a 1.0V difference between the end stops).
- (8) Ball joint securely fixed to quadrant/tiller.

Compass Installation

- (1) Mount the unit upright on a flat, vertical bulkhead.
- (2) A safe distance from external magnetic interference: 1m/3ft from VHF, loudspeakers, depth sounders, engines, power cables carrying heavy current, etc., 3m/10ft from radar and SSB equipment. Check the other side of bulkheads.
- (3) Reasonably well protected from direct physical damage.
- (4) With the connector facing downwards.
- (5) Fitted as near to centre of motion of boat as other factors allow, aft of centre preferred as there is usually less motion than forward of centre.

Electronics Installation

- (1) Secure the unit in the selected site using the non-magnetic self-tapping screws provided.
- (2) Cables secure.
- (3) Cables undamaged.
- (4) No loose bits of wire.
- (5) Screens connected in accordance with wiring instructions and sleeved where appropriate.

3.1.3 Parameters to be Set

The following is a list of the parameters that have to be set during commissioning. They are selected by pressing the keys indicated on the diagrams while in commissioning mode. Each parameter is explained in the following sections:

B TYPE	Select boat type: Sail, Power P, Power D
SWING	Compass Deviation Correction
H SRC	Heading Source, compass data selection
H OFF	Heading Offset, compass alignment correction
DIP	Magnetic DIP Angle compensation
DRIVE	Rudder drive type selection
RUD P	Rudder end stop Port
RUD S	Rudder end stop Starboard
RUD M	Rudder mid position
RUD T	Rudder Hard-over time
S CAL	Speed sensor calibration
B LEN	Boat waterline length in metres
B LAG	Boat Lag value
R GAN	Rudder Gain value
LOCK	Watch alarm lock facility, disables alarm on/off control

3.2 COMMISSIONING MODE SELECTION

3.2.1 Entering Commissioning Mode

Notes

1. The autopilot must be in **STANDBY** to carry out this operation.
2. If it is the first time the autopilot has been commissioned, **SELECT** will be displayed instead of **SAIL**, **PWR P** or **PWR D**.

(1) To enter the commissioning mode simultaneously press the < > Keys next to the **COURS** legend.

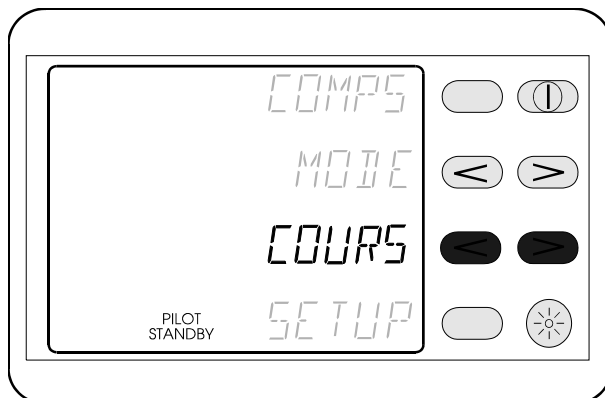

(2) To scroll backwards and forwards through the list of commissioning parameters, press either of the < > keys next to the **B TYPE** legend.

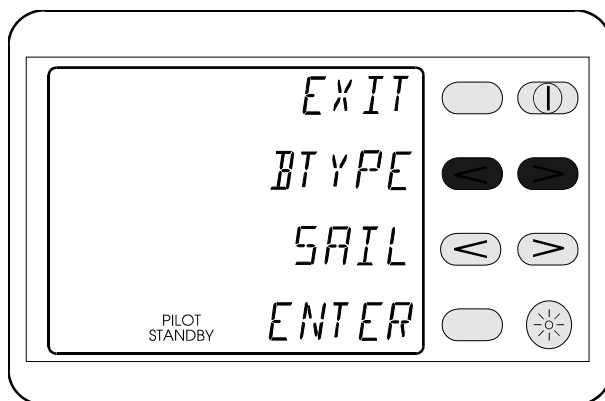

(3) To exit commissioning mode press the key next to the **EXIT** legend.

3.3 COMMISSIONING/CALIBRATION ALONGSIDE

The following parameters should be set before a sea trial:

- B TYPE** Select boat type: Sail, Power P, Power D
- H SRC** Heading Source, compass data selection
- H OFF** Heading Offset, compass alignment correction
- DIP** Magnetic DIP Angle compensation
- DRIVE** Rudder drive type selection
- RUD P** Rudder end stop Port
- RUD S** Rudder end stop Starboard
- RUD M** Rudder mid position
- RUD T** Rudder hard-over Time
- B LEN** Boat waterline length in metres

3.3.1 Boat Type Selection (B TYPE)

Three selections are available:

- SAIL** For all sailboats
- PWR D** For powerboats with displacement hulls
- PWR P** For powerboats with planing hulls

3.3.2 Setting the Boat Type

- (1) Select **B TYPE** from the menu.
- (2) Press the < > keys and select **SAIL** or **PWR P** or **PWR D**.
- (3) Press **Enter** to store the parameter.

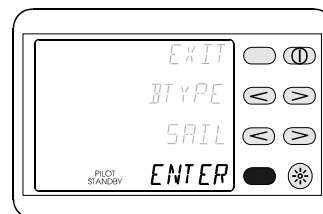
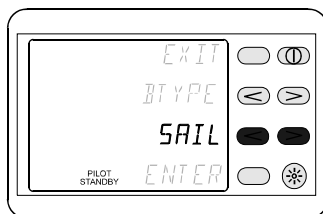
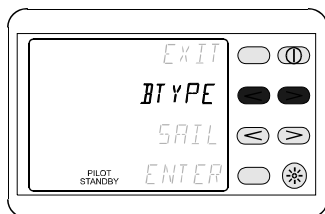

3.3.3 Heading Source (Compass) H SRC

The Heading Source setting defines the source for compass data. This setting is determined by the type of heading sensor connected to the system.

Most systems will use the Halcyon 2000 compass unit. The compass sensor supplies heading data via the Fastnet cable to the autopilot and instruments. However, some systems may have a Halcyon Gyro Sensor fitted. This could be in addition or in lieu of the Halcyon 2000 compass. Settings are available to select any of the compass sensors, select the correct one for the system from the table below:

H SRC	COMPASS DATA
5	Super Halcyon 3, connected via the h2000 instrument system
9	NMEA Data input into Hercules Performance Processor
15	Halcyon Gyro Stabilised Compass System
15	NMEA Data input into Halcyon Gyro Processor
16	Halcyon 2000 Compass
18	Gyro Sensor Connected to Autopilot ACP Processor
96*	NMEA Data input into NMEA FFD * NMEA FFDs are sequentially numbered dependent on the number of displays connected to the system; i.e. 96, 97, 98 . . .

Table 3.1 Compass Data

3.3.4 Setting the Heading Source Value

- (1) Select **H SRC** from the menu.
- (2) Select the value from the table.
- (3) Press **Enter** to store the value.

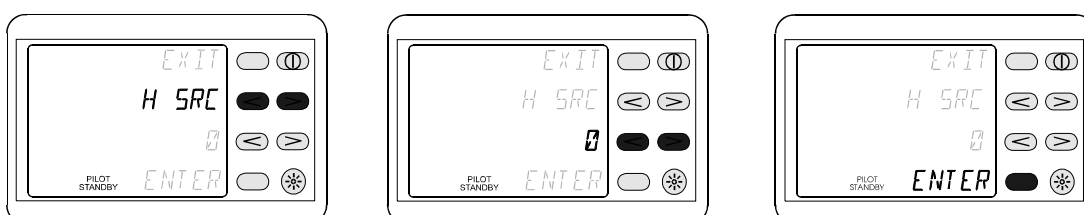

3.3.5 Heading Offset (Compass Alignment) H OFF

The Compass Alignment electronically compensates for the misalignment between the autopilot's fluxgate compass and the Earth's magnetic field.

The boat's actual heading must be known; use a calibrated bowl compass or hand-held compass for reference.

Enter the heading offset (in degrees) to correct the misalignment, in the range -180 to +180. For example: the boats actual heading is Due North, 000. The autopilot display is indicating West, 270.

Enter the heading offset value of +90. The heading offset should be checked during a sea trial to ensure that it has been entered accurately.

3.3.6 Adjusting the Heading Offset

- (1) Select **H OFF** from the menu.
- (2) Calculate the correct value for the offset.
- (3) Press **Enter** to store the value.

3.3.7 Magnetic DIP Angle (DIP)

All magnetic compasses are affected by "Northerly turning errors" in the Northern Hemisphere or "Southerly turning errors" in the Southern Hemisphere, which increase with Boat Speed and Magnetic DIP Angle in higher latitudes. These can cause heading instability at boat speeds greater than 20 knots when steering with an autopilot. By entering the dip value indicated on the compensation chart, the autopilot will be able to correct for these errors and improve the heading stability. Use the minimum value necessary to stabilise the heading.

Note

This applies to boats faster than 20 Knots only.

3.3.8 Setting the Magnetic DIP Value

- (1) Select **DIP** from the menu.
- (2) Select the correct value from the chart below.

(3) Press **Enter** to store the value.

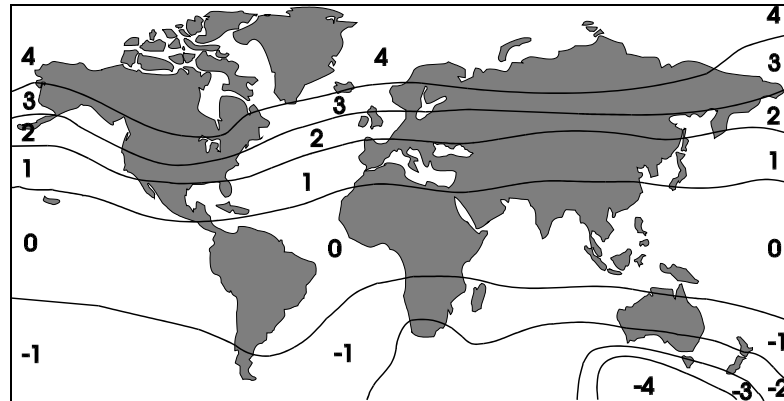
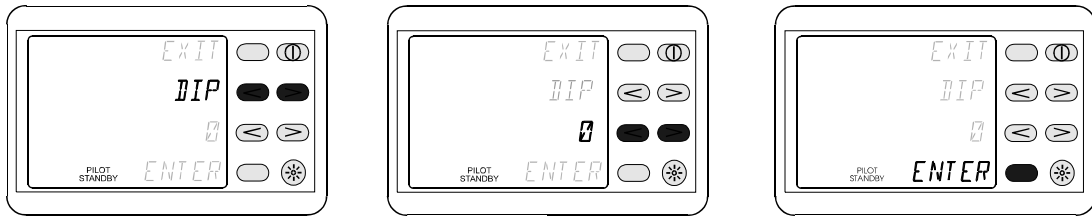

Fig 3.1 Magnetic DIP Angle Corrections

3.3.9 Rudder Drive Type (Drive)

Note

Depending upon the type of rudder drive unit fitted, the autopilot controls the rudder drive motor in different ways; this optimises the autopilot steering response.

There are three selections for **DRIVE**:

- TYP-A** All Linear Rams, Hydraulic pumps and Rotary drives.
- TYP-B** Pedestal drive motors fitted by some steering gear manufacturers.
- TYP-C** Outdrive drive units and Continuous drive units.

3.3.10 Setting the Drive Type

- (1) Select **DRIVE** from the menu.
- (2) Select the correct value from the list above.
- (3) Press **Enter** to store the drive type.

3.3.11 Setting the Rudder End Stops

Before the autopilot can be used, the position of the rudder end stops must be entered.

Notes

1. If the boat is equipped with hydraulically power assisted steering, the engines must be running whilst setting the end stops.
2. The rudder hard-over to hard-over time can only be calculated if the boat is stationary and there is no fixed speed entered.

RUD P - Setting the Port End Stop

- (1) Select **RUD P** from the menu.
- (2) Turn the wheel until the rudder is hard-over to Port.
- (3) Change the **OFF** legend to **ON** using the next keys.
- (4) Press **Enter** to set the Port end stop position. The display reverts to **OFF**.

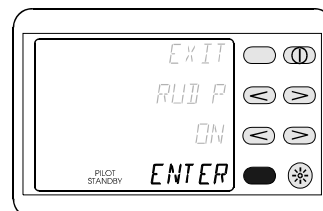
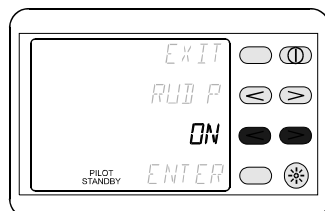
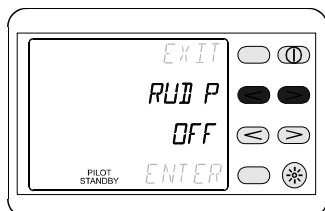

RUD S - Setting the Starboard End Stop

- (1) Select **RUD S** from the menu.
- (2) Turn the wheel until the rudder is hard over to Starboard.
- (3) Change the **OFF** legend to **ON** using the adjacent keys.
- (4) Press **Enter** to set the Starboard end stop position. The display reverts to **OFF**.

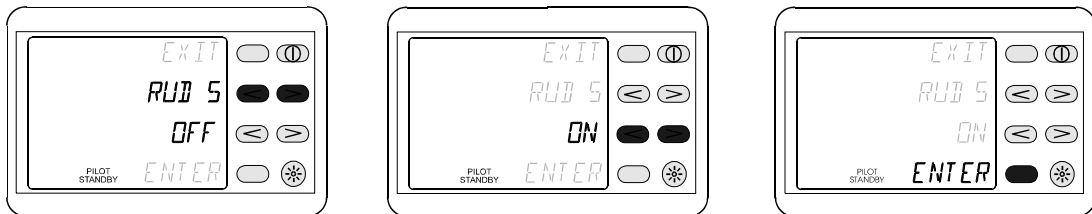

RUD M - Setting the Midships Position

- (1) Select **RUD M** from the menu.
- (2) Turn the wheel until the rudder is amidships.
- (3) Change the **OFF** legend to **ON** using the adjacent keys.
- (4) Press **Enter** to set the midships position. The display reverts to **OFF**.

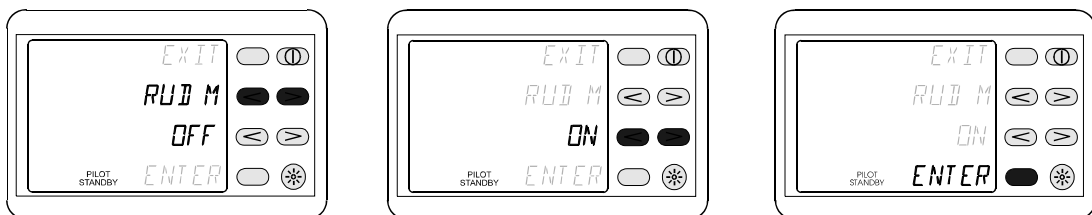

Notes

1. Due to hull design and steering characteristics the best rudder amidships position can only be set when underway, at normal cruising speed. It is therefore necessary to re-adjust the midships position during a sea trial.
2. When entering end stops, ensure that the helm is moved all the way to the end stop position. The autopilot automatically limits the amount of travel when operating to prevent damage to the system.

RUD T - Rudder Hard-Over Time

To finish the rudder end stop commissioning procedure the autopilot must calculate the rudder hardover Port to hardover Starboard time. The following points must be observed before carrying out the procedure:

- (a) If the boat is equipped with hydraulic power assisted steering, the engines must be running during the rudder hard-over time test.
- (b) The rudder hard-over to hard-over time can only be calculated with the boat stationary.
 - (1) Select **RUD T** from the menu.
 - (2) Change the **OFF** legend to **ON** using the adjacent keys.
 - (3) Press **Enter** to start the timing. The autopilot will drive the rudder to measure the hard over to hard over time.

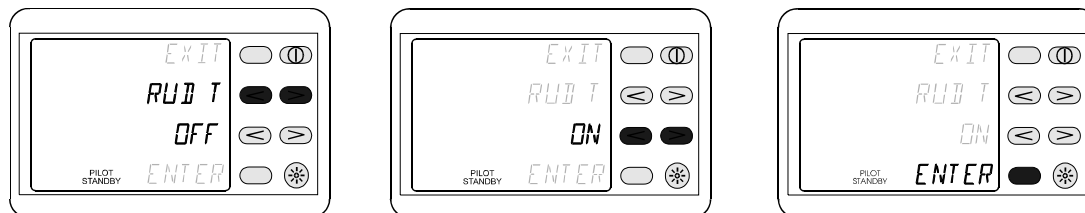

WARNING

ENSURE THAT HANDS ETC. ARE KEPT CLEAR FROM THE STEERING MECHANISM BEFORE PERFORMING THE RUDDER HARD-OVER TIME.

Note

If **RUD T** fails to work then check the boat speed; this must be less than 2 knots. Turn the wheel and check that the rudder bar display on the autopilot display is indicating. If it fails to indicate carry out the end stop procedures again. The rudder reference unit must move through a minimum of 90° when the wheel is turning from lock to lock. Check to ensure that there is a minimum of a 1V dc change from Port to Starboard measured between the Green and Blue wires from the rudder position sensor.

3.3.12 Setting the Boat Length (B LEN)

The boat's waterline length in Metres must be entered into the autopilot for it to steer accurately.

- (1) Select **B LEN** from the menu.
- (2) Enter the correct waterline length in metres.
- (3) Press **Enter** to set the value.

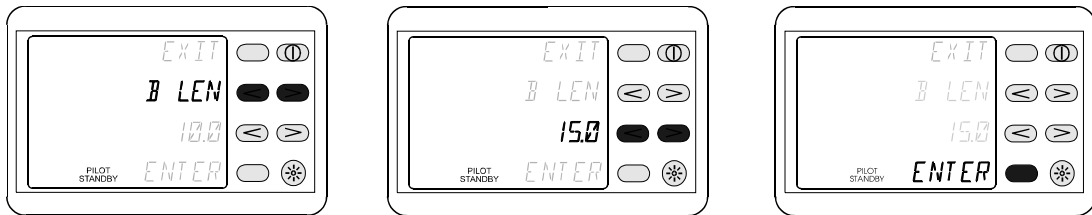

Caution

Until all parameters have been set or checked, the autopilot should not be used to steer the boat.

3.4 SEA TRIAL COMMISSIONING/CALIBRATION

3.4.1 Introduction

To complete the setting of parameters and commissioning procedure a sea trial is necessary.

The following parameters should be set and checked during the initial sea trial:

- SWING** Compass Deviation Correction
- H OFF** Heading Offset, compass alignment correction
- RUD M** Rudder mid position
- S CAL** Speed sensor calibration
- B LAG** Boat lag value
- R GAN** Rudder gain value
- LOCK** Watch alarm lock facility, disables alarm on/off control

The commissioning sea trial should be carried out under power in open water on a calm day. The procedures for the remainder of the commissioning involve continual course and speed changes, it is therefore important that a constant look out is maintained.

The autopilot will initially operate from the factory default values for Boat Lag (**B LAG**) and Rudder Gain (**R GAN**). These are different for sail or powerboats. During the sea trial the autopilot learning algorithm will automatically set and adjust the value for rudder gain. The values for boat lag and rudder gain will be checked and adjusted to finely tune the autopilot steering performance when necessary. The default values for steering are automatically set dependent upon the type of vessel as set by boat type (**B TYPE**).

Notes

1. On the initial sea trial **DO NOT EXCEED 15 KNOTS**. Sailboats should be commissioned at the normal cruising speed.
2. Always maintain a proper lookout.
3. If in doubt, disengage the autopilot with the **Red Off** Key on any Autopilot Display or Hand-held Controller, and return to manual steering.

To Engage the Autopilot

- (1) Steer the boat onto a suitable heading, allow time for the boat to settle on this course.
- (2) Engage autopilot in **COMPS** (compass) mode.
- (3) The autopilot will now be steering the boat on the selected heading. Alter course in multiple increments using the 10° and 1° course change buttons on any Autopilot Display or Hand-held Controller.

To Disengage the Autopilot

- (1) Press the **Red Off** Key to disengage the autopilot and return to manual steering.

3.4.2 Verify Rudder Power Drive

Power Steer mode can be used to verify that the rudder drive is operating correctly. This mode allows the user to directly control the boat's rudder by using any Autopilot Display or Hand-held Controller course change keys.

This facility could be used in an emergency if the normal manual steering system became defective, e.g. a broken steering quadrant cable or control rod. It can also assist with diagnosis of faults in the ram drive unit, drive pump or the rudder reference unit and its linkage to the steering system since the autopilot normal course control software is by-passed.

3.4.3 Selecting Power Steer Mode

Note

The autopilot must be in STANDBY.

- (1) Turn the wheel so the rudder is in the amidships position (if possible).
- (2) Press the key next to the **POWER** legend.
- (3) To exit power steer mode press the **Red Off Key**.

Note

When the **MID** Key is pressed, the rudder will return to the position it was in when **POWER** steer was engaged. If the rudder was set at the amidships position then **MID** Key will return it to that position.

- (4) Press the keys next to the **MODE** legend until **POWER** is displayed on the top line. With the rudder amidships, press the key next to the **POWER** legend to engage the autopilot in power steer mode.
- (5) Use the < < or > > Keys to adjust the rudder position by 3°. Use the < or > Keys to adjust the rudder position by 1°. Press **MID** to return the rudder to the amidships position.

3.4.4 Power Steer Check

- (1) Engage the autopilot, check clutch/bypass valve operation.
- (2) With the autopilot engaged, try to move rudder with the wheel. The backlash should be less than 1° of rudder movement. Investigate and rectify any backlash steering problems immediately.

(3) Use the << >> Keys to move the rudder, check that the autopilot can move the rudder by large amounts, verify by watching the rudder angle on the display, each press should give approximately 3° rudder movement.

(4) Use the < > Keys to move the rudder, check that the autopilot can move the rudder by small amounts, verify by watching the rudder angle on the display, each press should give about 1° rudder movement.

3.4.5 Autopilot Gyro Compass Calibration

This procedure will automatically correct the Autopilot's Gyro Compass Sensor connected directly to the ACP unit for any deviation errors. It should be carried out in open water, preferably on a calm day, with minimal wind, waves and minimum traffic.

Note

If the autopilot is using the Halcyon 2000 Compass or Halcyon Gyro Stabilised Compass System, the calibration procedure described in section 3.4.6 is the same.

3.4.6 Calibrating the Autopilot Gyro Compass

(1) Scroll through the commissioning parameters until **SWING** is displayed.

(2) Change the **OFF** legend to **ON** using the adjacent keys.

(3) Press **Enter** to start the swing.

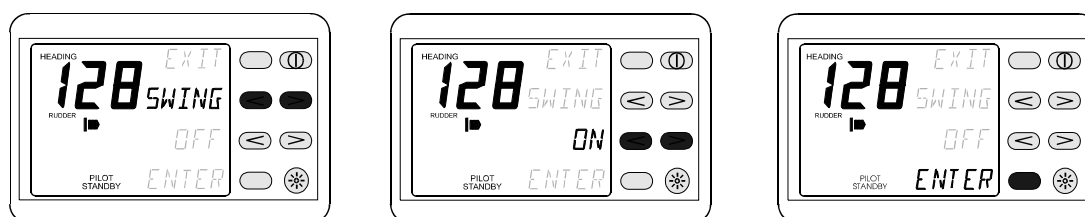

Note

The **COMPASS SWING** can be stopped at any time by pressing the **Exit** Key.

(4) With the speed below 5 knots, turn the boat through 360° up to a maximum of 720° at a rate of turn not greater than 2° per second. The display will show the amount of turn completed so far in degrees.

(5) Keep turning until **PAS** (PASS) or **FAIL** is displayed.

PAS will alternately be displayed with a number that indicates the correction coefficient applied. The number is for reference only.

If **FAIL** shows the swing was unsuccessful, the display will return to **000°** and the procedure will have to be repeated.

3.4.7 Setting the Heading Offset Value (H OFF)

The heading offset was originally set while the boat was alongside. It is advisable that the offset value is checked after the Compass Swing has been completed. Refer to Setting the Heading Offset to review the procedure in full.

- (1) Select **H OFF** from the menu.
- (2) Calculate the correct value for the offset.
- (3) Press **Enter** to store the value.

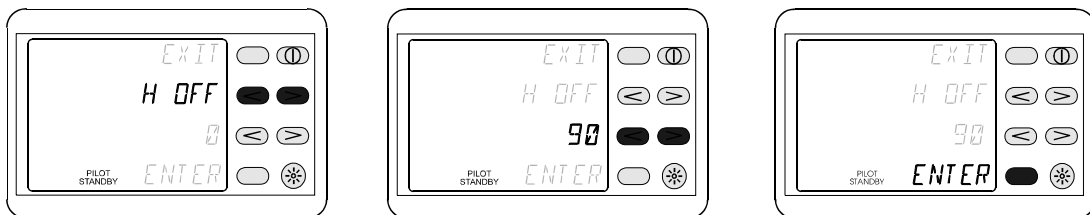

3.4.8 Calibration of Speed Input (S CAL)

The ACP Computer Unit can take a direct speed input from a Paddle Wheel with a hall-effect output. Normally the autopilot uses boat speed supplied via the Fastnet cable from the Instrument System, this facility is only used when the installation does not include an H-range Instrument System.

All B&G paddle wheel type speed sensors are compatible. The Hertz/Knot value is entered into the system to ensure the autopilot steering response is controlled with reference to boat speed. The default Hertz/Knot value is 3.80; this is the default setting for B&G speed sensors.

To determine if the value is correct compare the boat speed value displayed by the autopilot display (when the **Speed** Key is pressed) with the displayed value of speed on the log/speedometer fitted.

3.4.9 Setting the Speed Calibration Value

- (1) Select **S CAL** from the menu.
- (2) Adjust the value with the **< >** Keys.
- (3) Press **Enter** to set the value.

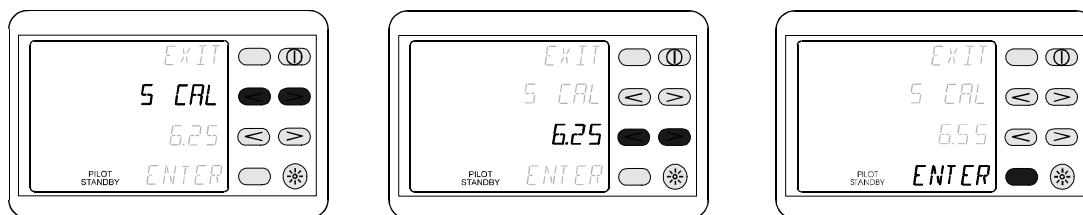

Note

The speed cal reading is inversely proportional; i.e. to increase the boat speed, decrease the Hertz/Knot value.

3.4.10 Rudder Gain (R GAN)

When the autopilot is part of an integrated system, boat speed data is supplied via the Fastnet cable from the h2000 Instruments. By monitoring boat speed and rate of turn the autopilot will automatically 'learn' the correct value for Rudder Gain giving a rate of turn of approximately 6° per second for a sail boat or 8° for a power boat.

If there is no direct speed input or the speed is being set by the Autopilot Display Manual Speed Band selections, then the Rudder Gain value must be entered manually; for these types of installations omit this section and proceed to Manual Rudder Gain.

3.4.11 Checking Rudder Gain Learning

- (1) Steer the boat onto a suitable heading, allow time for the boat to settle on this course.
- (2) Engage the autopilot in **COMPS** (compass) mode.
- (3) **AT A SPEED NOT EXCEEDING 15 KNOTS**, make at least 6 large course changes of at least **100°** (ideally 170°) by multiple presses of the **10°** course change buttons on any Autopilot Display or Hand-held Controller. This enables the autopilot to learn the rudder gain value.
- (4) When the autopilot has learnt the rudder gain value the rate of turn will be approximately **6°** (sail) or **8°** (power) per second. To estimate the rate of turn the display is updated twice per second, therefore the heading display should jump in **3°-4°** steps.
- (5) Press the **Red Off** Key to disengage the autopilot and return to manual steering.

3.4.12 Setting the Rudder Gain Manually

- (1) Steer the boat onto a suitable heading; allow time for the boat to settle on this course.
- (2) Engage the autopilot in **COMPS** (compass) mode.
- (3) **AT A SPEED NOT EXCEEDING 15 KNOTS**, make at least six large course changes of at least **100°** by multiple presses of the **10°** course change buttons on any Autopilot Display or Hand-held Controller.
- (4) Observe and estimate the rate of turn. It should be approximately **6°** to **8°** per second. To estimate the rate of turn the display is updated twice per second, therefore the heading display should jump in **3°** to **4°** steps.

(5) Observe the performance of the autopilot when changing course. The rudder gain value is inversely proportional, therefore, if the rate of turn is too **SLOW**, **REDUCE** the value of rudder gain and the autopilot will use more rudder. If the rate of turn is too **FAST**, **INCREASE** the value of rudder gain and the autopilot will use less rudder.

(6) Adjust the Rudder Gain to give an average rate of turn of approximately **6° to 8°** per second.

Boat Type	Factory Set Value	Typical Values
Sail Boats	2.0	1.0 to 3.0
Power Boats	0.8	0.3 to 1.0

Table 3.2 Rudder Gain Value

Note

The factory set value is selected by setting Boat Type and Rudder Drive Type during commissioning.

3.4.13 SETTING THE RUDDER GAIN VALUE

Note

The autopilot must be disengaged and in commissioning mode to adjust the Rudder Gain value.

- (1) Select **R GAN** from the menu.
- (2) Adjust the value with the **< >** Keys shown.
- (3) Press **Enter** to set the value.

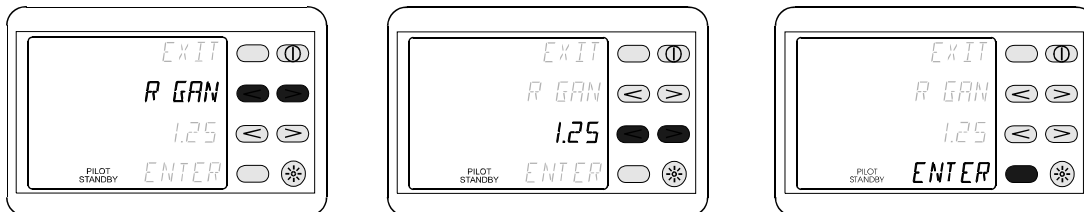

3.4.14 Boat Lag Value

Boat Lag is the time taken for the boat to respond to changes in helm. For example, heavy displacement hulls require a larger value for boat lag.

3.4.15 Checking the Boat Lag

- (1) Engage the autopilot as previously explained in Initial Autopilot Sea Trial.
- (2) At a speed not exceeding 15 knots, change course by **90°** in each direction.
- (3) Observe the autopilot steering performance. The boat should turn onto the new heading with minimal overshoot (a slight overshoot is acceptable).
- (4) If the overshoot is consistently more than **5°** for course changes in both directions increase the Boat Lag value in steps of 0.1 until the overshoot is corrected.
- (5) It is easier to spot overshoot than undershoot, hence if no overshoot is observed decrease the boat lag in steps of 0.1 until a small overshoot is seen. Use the smallest value of Boat Lag to stop overshoot.

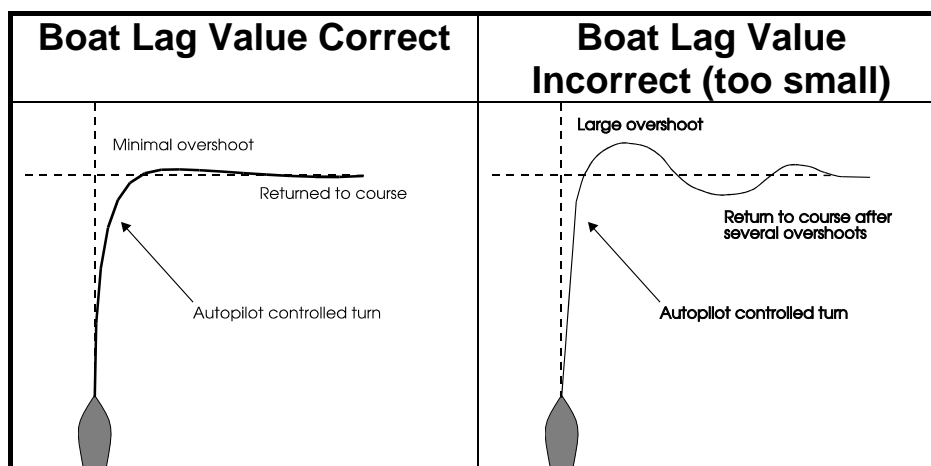

Fig 3.2 Boat Lag Response

Boat Type	Factory Set Value	Typical Values
Sail Boats	0.3	0.3 to 1.0
Power Boats	0.5	0.3 to 1.0

Table 3.3 Boat Lag Value Table

Note

The factory set value is selected by setting Boat Type and Rudder Drive Type during commissioning.

3.4.16 Setting the Boat Lag Value

Note

The autopilot must be disengaged and commissioning mode selected to adjust the Boat Lag value.

- (1) Select **B LAG** from the menu.
- (2) Adjust the value with the **< >** Keys.
- (3) Press **Enter** to set the value.

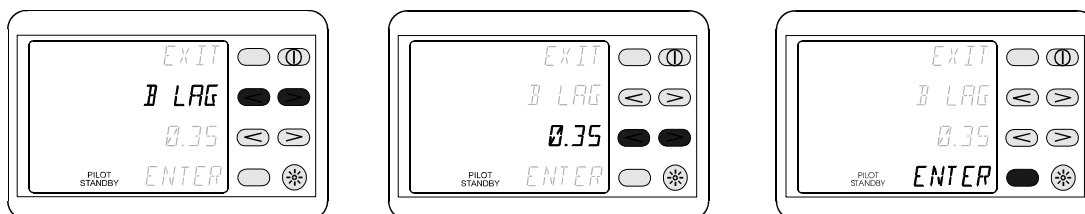

PART 4 - INSTALLATION INFORMATION

CONTENTS

Para		Page
4.1	CABLE AND CONNECTION INFORMATION	4-3
4.1.1	EMC Compliance	4-3
4.1.2	General Wiring Notes	4-3
4.1.3	Autopilot Drive Unit Cables	4-4
4.1.4	ACP Unit Terminal Details	4-5
4.1.5	Clutch Voltage Selection	4-6
4.1.6	Dip Switch Location	4-7
4.2	ACP WIRING CONNECTIONS	4-8
4.2.1	Network and Alarm Connections	4-8
4.2.2	Autopilot Display Connections	4-9
4.2.3	MOB, Joystick, Hand-held Controller Connections	4-10
4.2.4	Hydraulic Ram Drive Connections	4-11
4.2.5	Continuous Drive Connections	4-12
4.2.6	Direct Speed Input Connections	4-13
4.2.7	Linear Feedback Connections	4-14
4.2.8	Gyro Stabilised Compass Connections	4-15
4.3	ROTARY RUDDER REFERENCE SENSOR (RRF)	4-16
4.3.1	Installation of RRF	4-16
4.4	LINEAR FEED BACK UNIT	4-19
4.4.1	Linear Feedback Unit	4-19
4.5	RUDDER DRIVE UNIT	4-20
4.5.1	Description	4-20
4.5.2	Sterndrive Unit Connections	4-21
4.5.3	Rotary Drive Connections	4-22
4.5.4	Proportional Solenoid Connections	4-23
4.6	USING A NON-B&G SPEED SENSOR	4-24

CONTENTS (Contd.)

ILLUSTRATIONS

Fig No		Page
4.1	ACP Unit Terminal Details	4-5
4.2	DIP Switch Location	4-7
4.3	Network and Alarm Connections	4-8
4.4	Autopilot Display Connections	4-9
4.5	MOB, Joystick, Hand-held Controller Connections	4-10
4.6	Hydraulic Ram Drive Connections	4-11
4.7	Continuous Drive Connections	4-12
4.8	Direct Speed Input Connections	4-13
4.9	Linear Feedback Connections	4-14
4.10	Gyro Stabilised Compass Connections	4-15
4.11	Plan View - Typical System with Tiller Arm and Quadrant	4-17
4.12	Steering System Orientation	4-17
4.13	RRF Position	4-18
4.14	Drag-Link and RRF Position	4-18
4.15	Linear Feedback Unit	4-19
4.16	Sterndrive Unit Connections	4-21
4.17	Rotary Drive Connections	4-22
4.18	Proportional Solenoid Connections	4-23
4.19	Non-B&G Paddle Connection	4-24

TABLES

Table No		Page
4.1	All Rudder Drives - Heavy Duty Power Cables	4-4
4.2	Rams and Rotary Drives - Clutch/Valve Cables	4-4
4.3	Wire Colour Coding/Abbreviations	4-5
4.4	DIP Switch Selection	4-6
4.5	Non-B&G Paddle Connection	4-25

PART 4 - INSTALLATION INFORMATION

4.1 CABLE AND CONNECTION INFORMATION

4.1.1 EMC Compliance

B&G equipment is designed to be operated in leisure craft. Every care has been taken in the design and testing to ensure compliance with the European EMC Directive. Provided the equipment is installed and operated in accordance with the instructions supplied and the units and cables are used unmodified no problems should be encountered. Specific attention is drawn to the requirements to maintain cable separation, where stated. To comply with these regulations:

- (a) A supply line filter is required. This may be obtained from your installer quoting B&G part number: 990-00-001.
- (b) Ensure proper connection of cable screens.

Transmissions from poorly installed or maintained Single Sideband equipment may adversely affect the functioning of this equipment. On vessels fitted with an SSB, it is essential that such equipment be installed following good installation practice and as recommended by the manufacturer.

4.1.2 General Wiring Notes

CAUTION Do not apply power to the autopilot system until all units are connected and the wiring has been checked.

Where spade connectors are supplied always use the correct crimping tool to attach them to the cable. This is extremely important where cables carry high currents, i.e. rudder drive unit supply cables (ACP 1 - 25 Amps or ACP 2 - 40 Amps).

Keep supply cables as short as possible to reduce voltage drop in the cables.

Always fit a suitable fuse or circuit breaker in supply cables. A 25 Amp (ACP 1) or 40 Amp (ACP 2) MCB is essential for the heavy-duty power cables.

Clearly identify each cable to prevent incorrect connection.

All cables should be routed at least 1m/3ft from cables or components that carry or generate high currents, e.g. alternators, starter motors and cabling, trim-tab cables, etc.

To minimise interference avoid routing Network cables alongside high power radio or Radar cables, allow 3m/10ft spacing, or within 1m/3ft of engine starter motors and cables and other cables carrying heavy current.

To prevent damage to cabling always secure in position using cable clips or tie-wraps. Where cables pass through bulkheads always protect the cable from chafing by installing grommets.

Do not allow cables to rest in the bilge where prolonged immersion in water, fuel, etc. could occur.

Always fit splash covers and lids on processors, computer units and junctions boxes, where supplied.

4.1.3 Autopilot Drive Unit Cables

Cable Length	B&G Cable Part No.	Copper Area	Cable Gauge
Up to 8m/26ft	135-0A-128	4.0mm ²	12 AWG
Up to 12m/40ft	Not available	6.0mm ²	10 AWG
Up to 20m/65ft	Not available	10.0mm ²	7 AWG

Table 4.1 All Rudder Drives - Heavy Duty Power Cables

Cable Length	B&G Cable Part No.	Copper Area	Cable Gauge
Up to 9m/30ft	135-0C-096	0.5mm ²	22 AWG
Up to 15m/50ft	135-0B-096	0.5mm ²	22 AWG

Table 4.2 Rams and Rotary Drives - Clutch/Valve Cables

4.1.4 ACP Unit Terminal Details

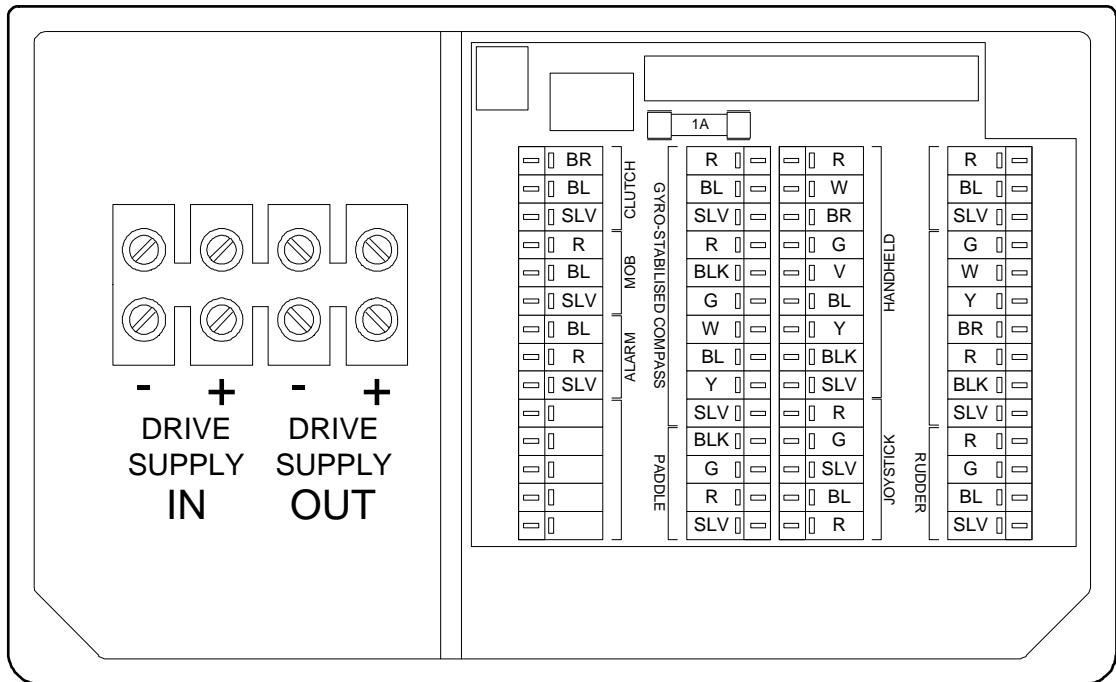

Fig 4.1 ACP Unit Terminal Details

R	Red	V	Violet
BLK	Black	Y	Yellow
BL	Blue	O	Orange
BR	Brown	W	White
G	Green	Blank	Silver N/C

Table 4.3 Wire Colour Coding/Abbreviations

4.1.5 Clutch Voltage Selection

The ACP Computer Unit can output different clutch/solenoid voltages depending upon the size of the rudder drive unit fitted. The clutch/solenoid valve is only required for rams or rotary drive units. This is achieved by setting dipswitches on the Computer Drive PCB in the lid of the Computer Unit.

Set the switches as per the table below. The default setting is 9V, switch 4 ON, suitable for Size 1, 12V Rams and Size 2, 12V Rams.

DIP Switch	Clutch Voltage	Drive Size/Type
4	24V	24V Rotary
3	18V	Size 3, 24V Ram
2	12V	12V Rotary
1	9V	Size 1 and 2 12V Rams (to save power)

Table 4.4 ACP DIP Switch Selection

Note: when using drives from another manufacturer, it is important to refer to the documentation supplied with that drive to determine the correct clutch voltage selection. Refer to the manufacturer of the drive for further information.

4.1.6 Dip Switch Location

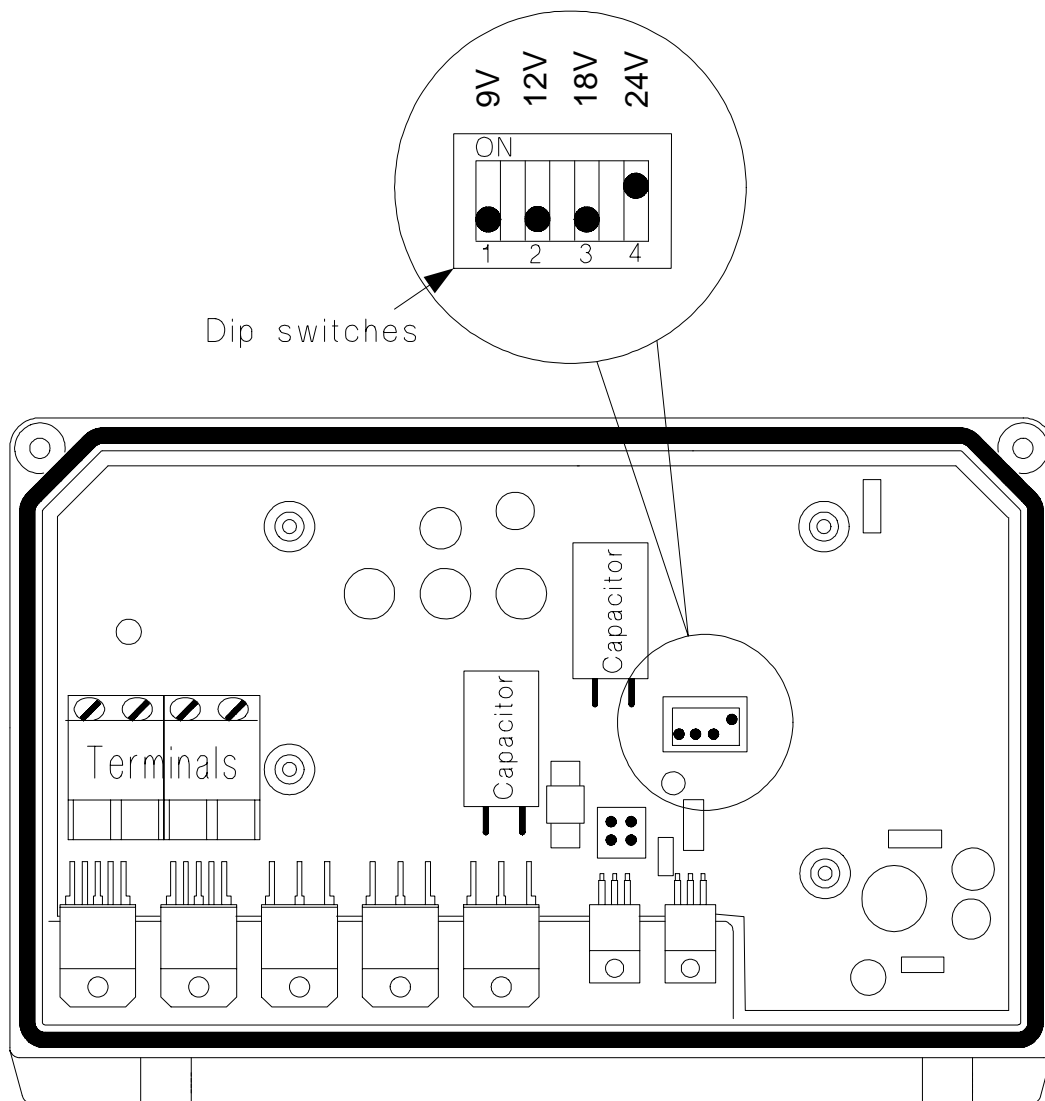

Fig 4.2 DIP Switch Location

4.2 ACP WIRING CONNECTIONS

4.2.1 Network and Alarm Connections

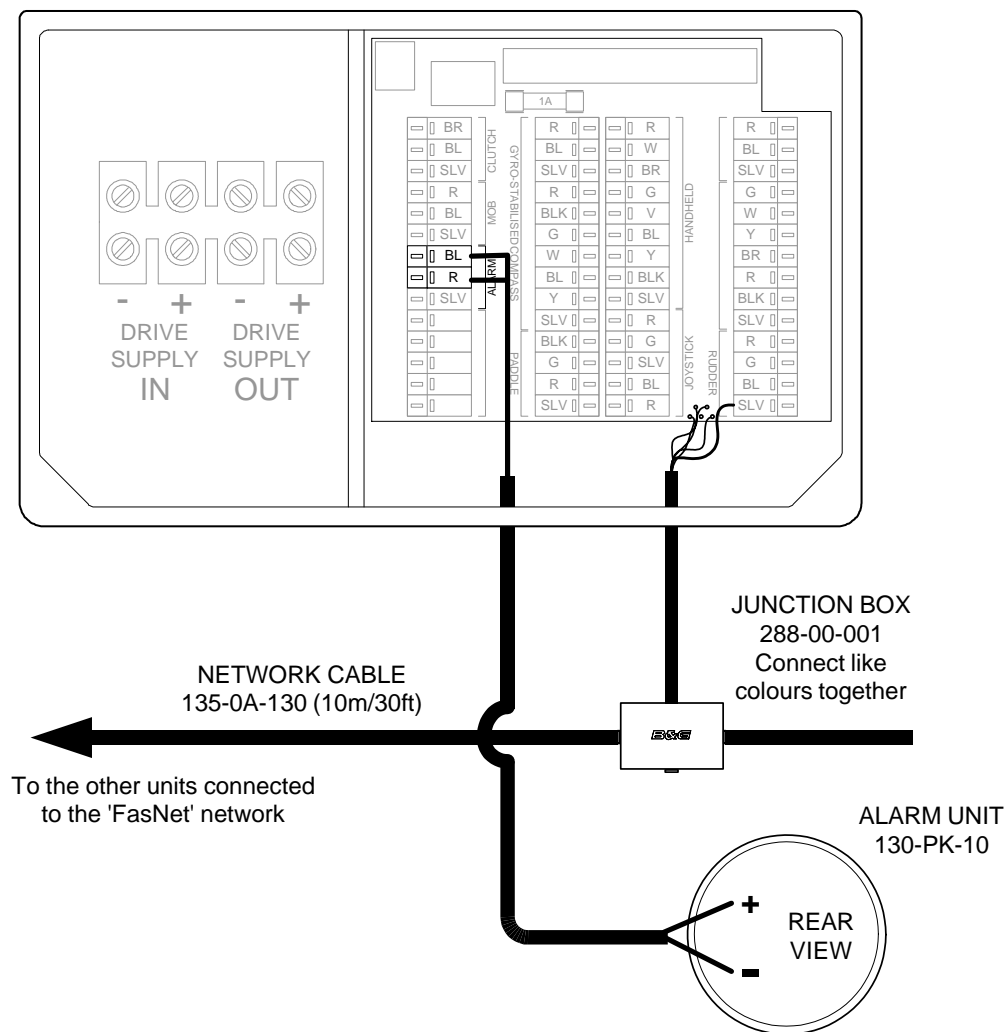
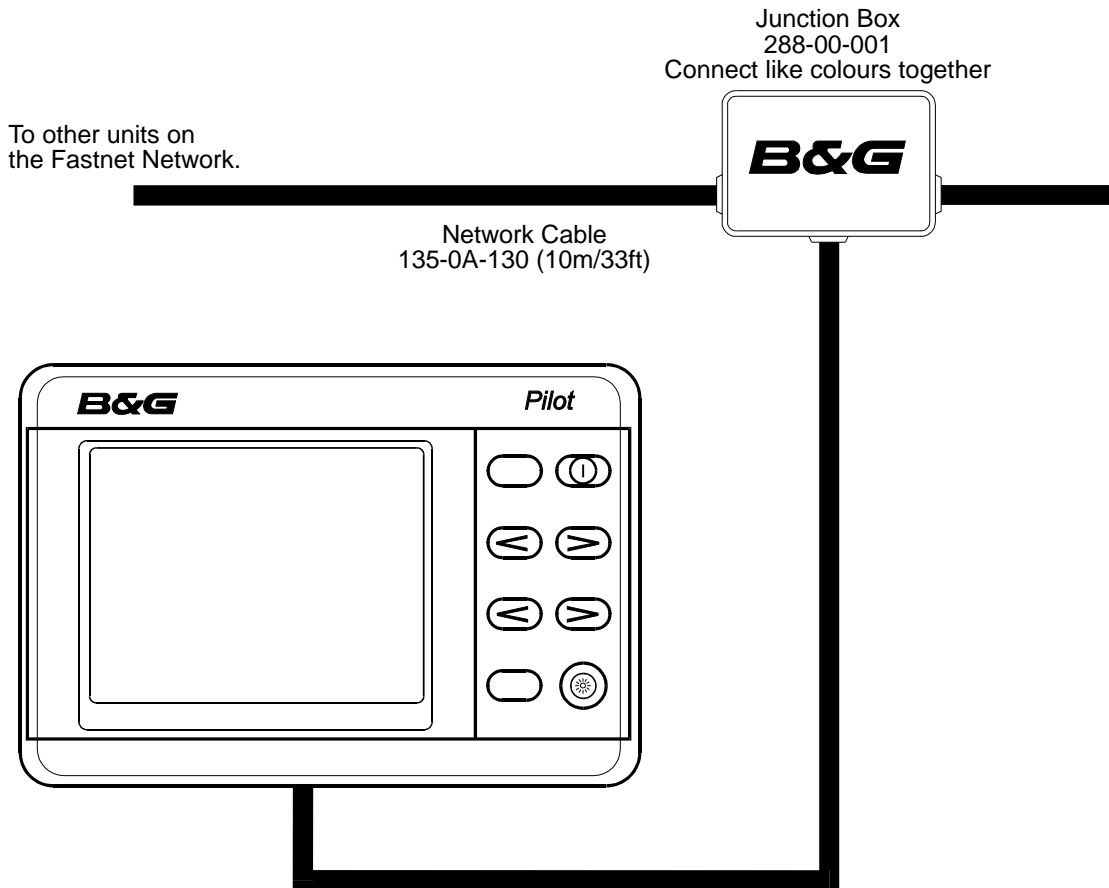

Fig 4.3 Network and Alarm Connections

Note: the maximum rating for the alarm output is 12V, 20mA.

4.2.2 Autopilot Display Connections



Note:
The extreme ends of the Fastnet Network should be terminated by connecting terminators between the white and green data wires. Maximum of two per system.

Fig 4.4 Autopilot Display Connections

4.2.3 MOB, Joystick, Hand-held Controller Connections

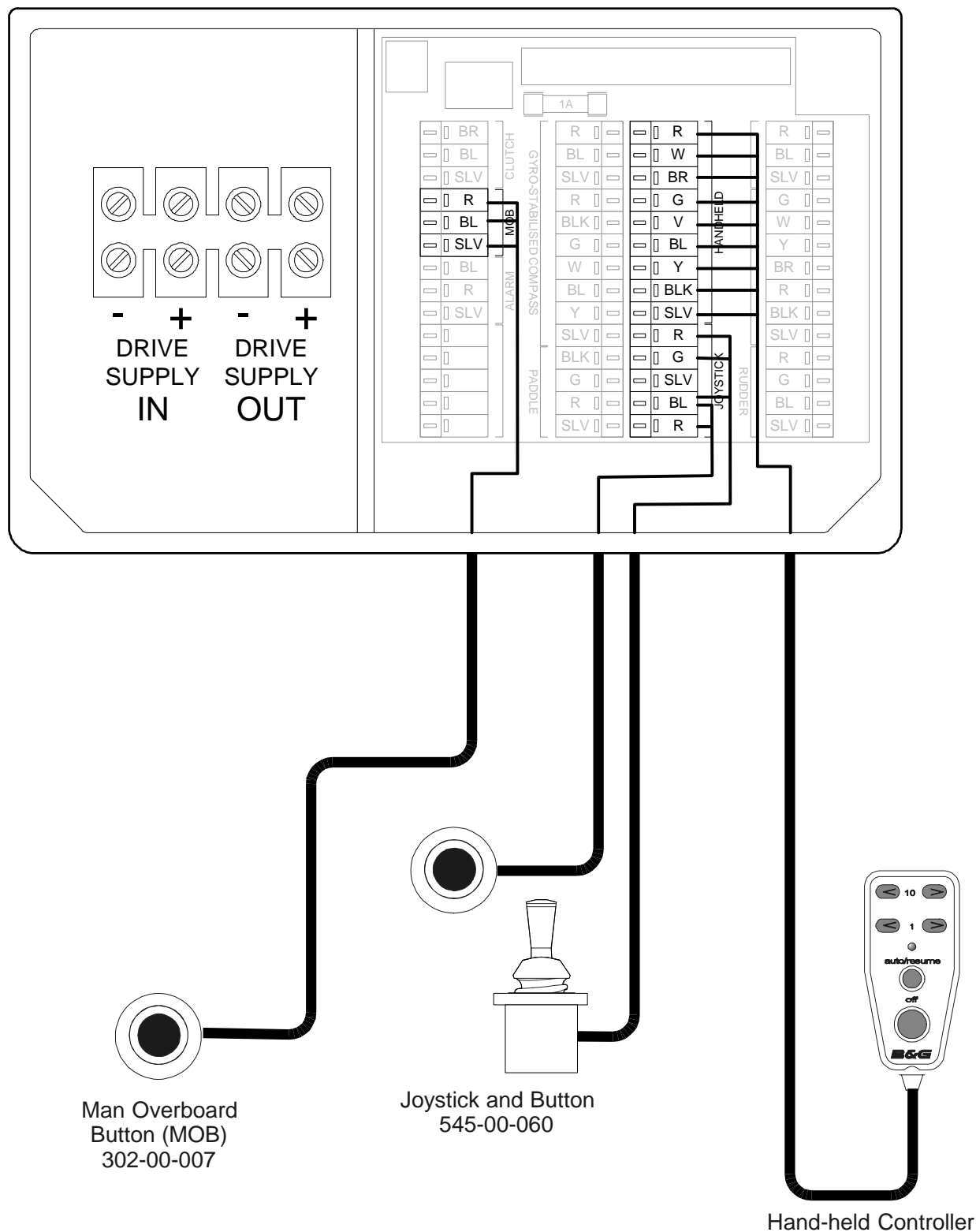

Fig 4.5 MOB, Joystick, Hand-held Controller Connections

4.2.4 Hydraulic Ram Drive Connections

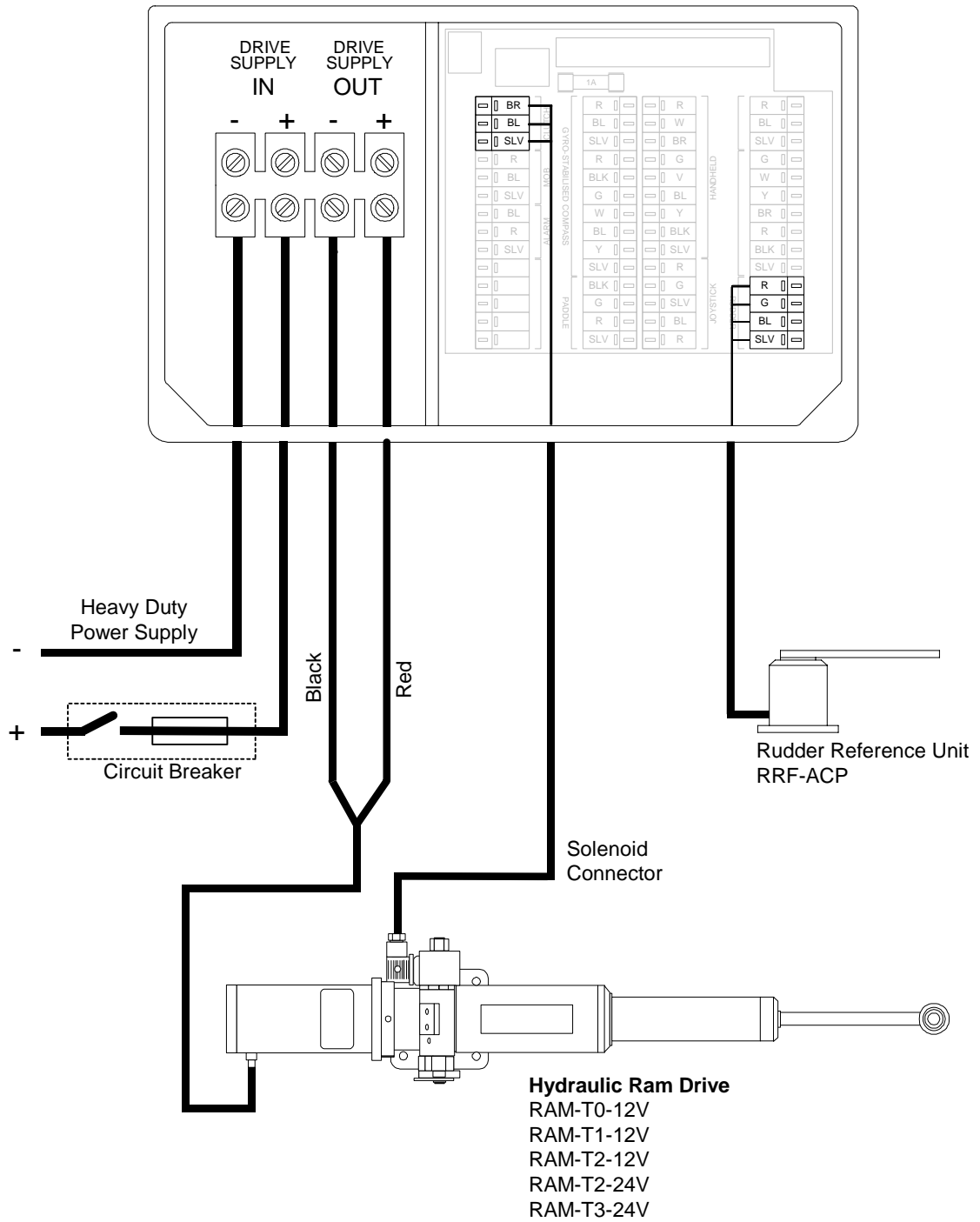

Fig 4.6 Hydraulic Ram Drive Connections

4.2.5 Continuous Drive Connections

These are general wiring instructions only, showing the implementation of the ACP outputs to drive a continuous drive pump solenoid valves. The continuous drive pump motor will also require a heavy-duty supply, which is not provided. However, suitable units can be obtained from your dealer. Clutch output is used to control the motor supply.

Note: The ram solenoid must be designed to operate at the same voltage as the pump.

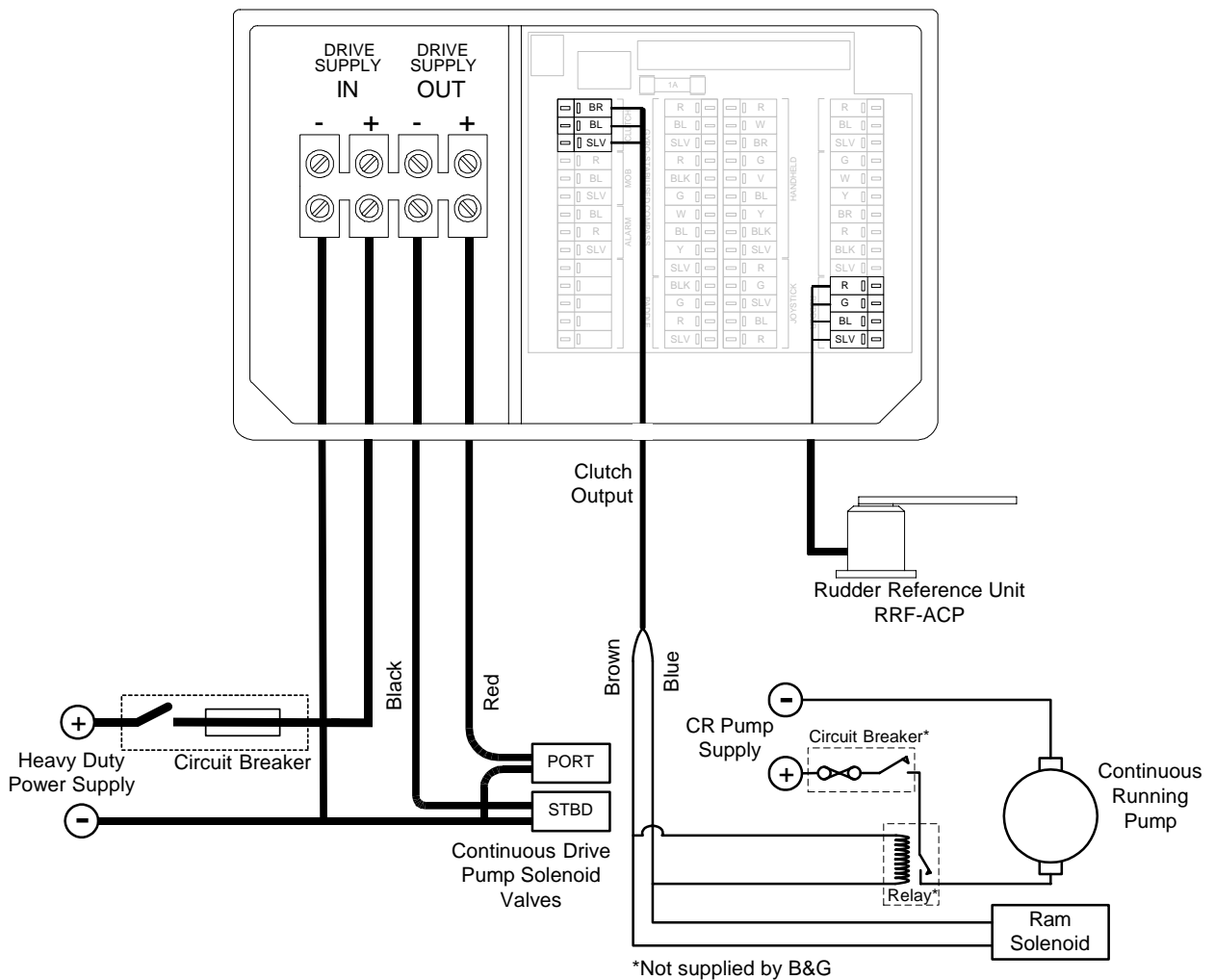
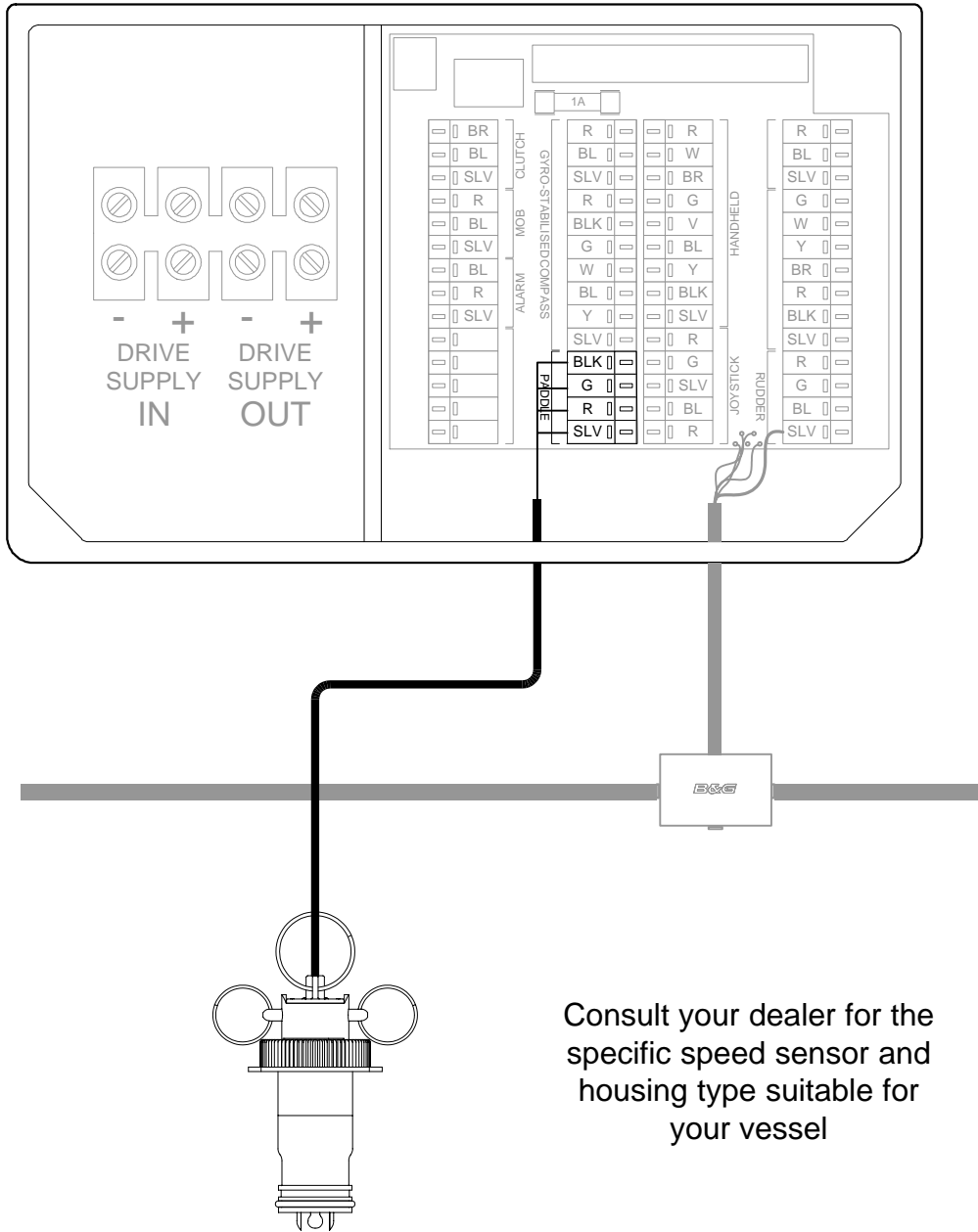

Fig 4.7 Continuous Drive Connections

4.2.6 Direct Speed Input Connections



Consult your dealer for the specific speed sensor and housing type suitable for your vessel

Fig 4.8 Direct Speed Input Connections

4.2.7 Linear Feedback Connections

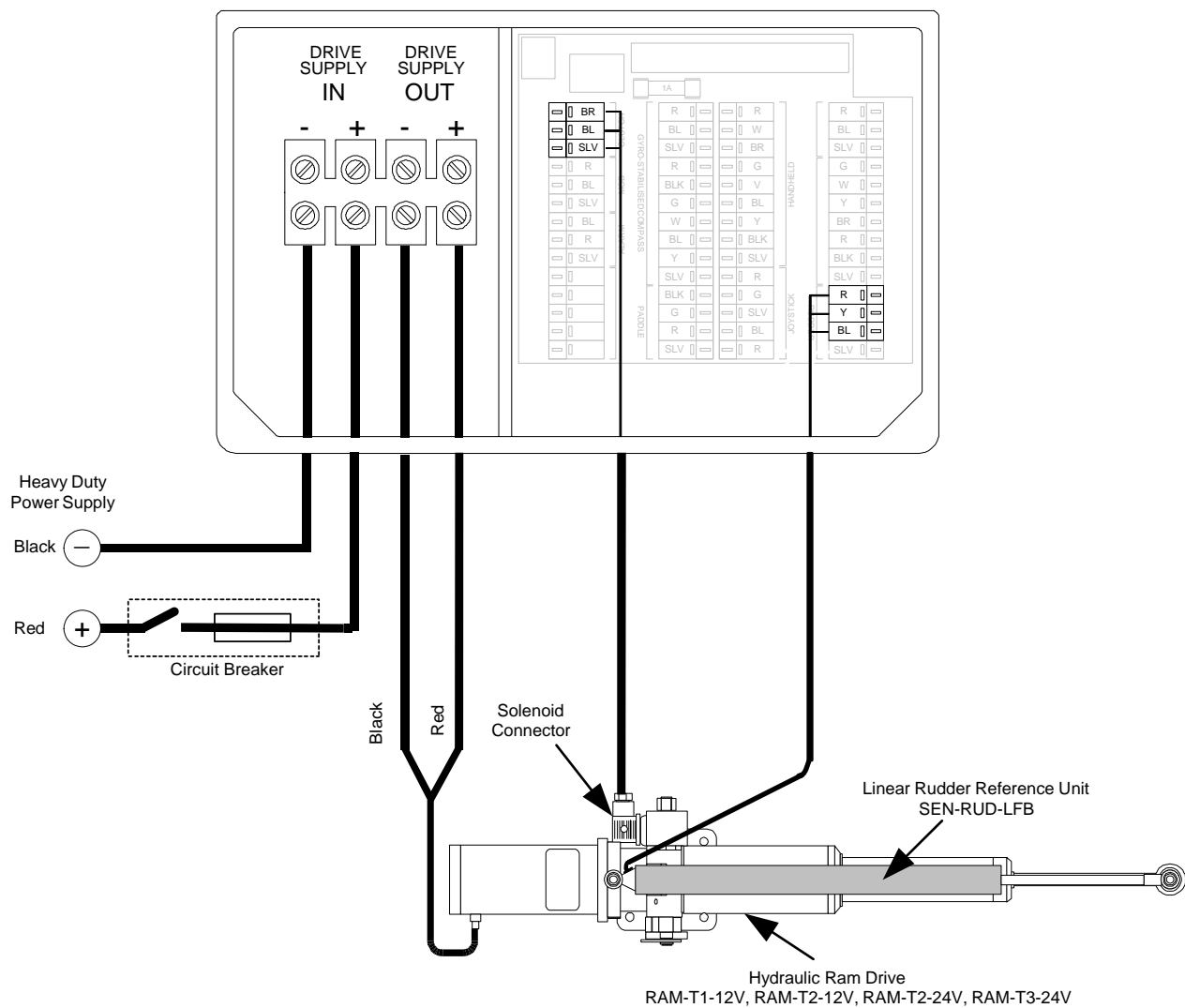

Fig 4.9 Linear Feedback Connections

4.2.8 Gyro Stabilised Compass Connections

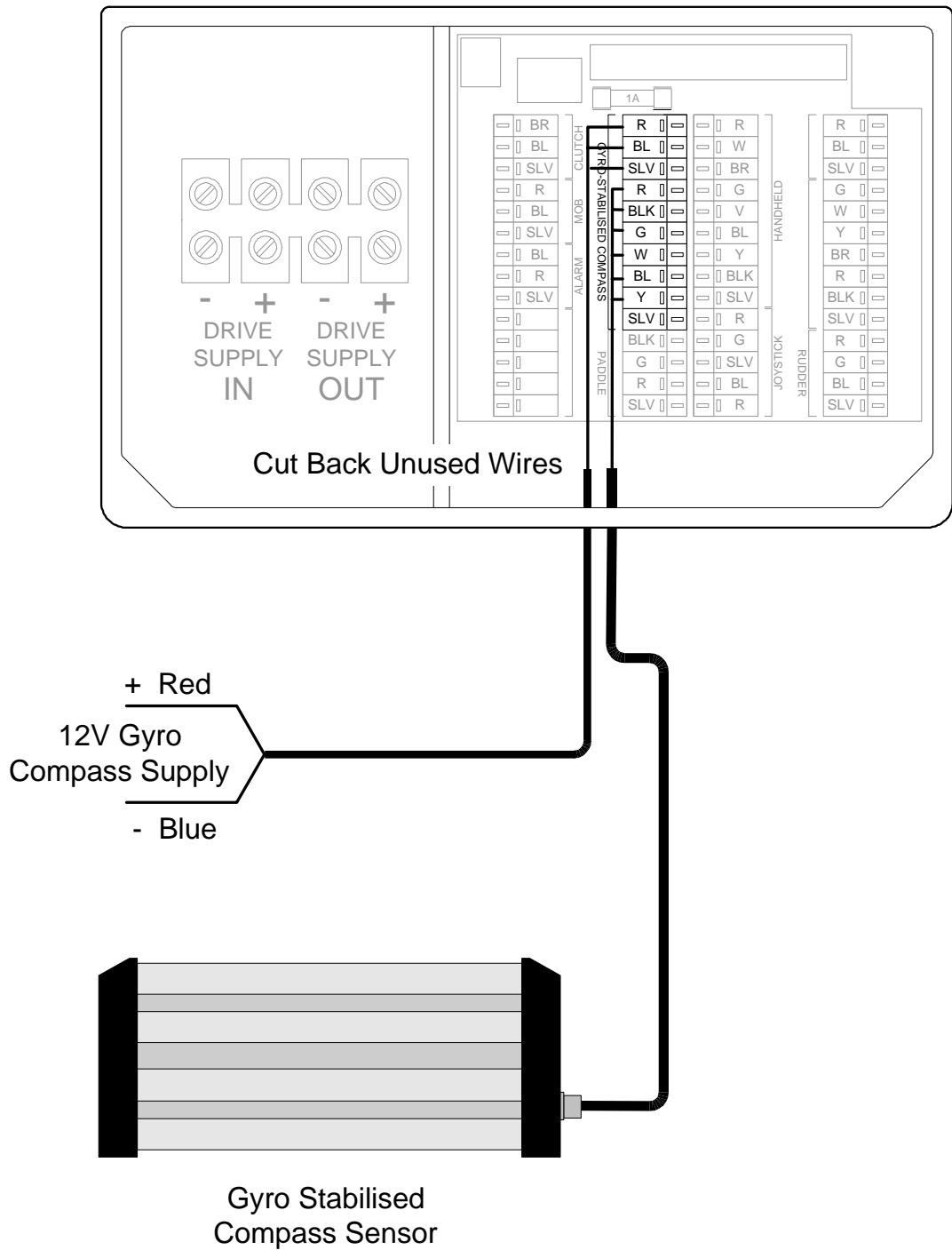

Fig 4.10 Gyro Stabilised Compass Connections

4.3 ROTARY RUDDER REFERENCE SENSOR (RRF)

4.3.1 Installation of RRF

A number of key points must be considered for optimum performance of the unit:

- (1) Mount the unit on a flat surface next to the tiller arm or steering quadrant. Construct a small platform if necessary.
- (2) Do not lengthen the drag-link arm as this can transmit excessive vibration to the sensor.
- (3) The sensor operating arm can be rotated through 360°. The mid-point of the RRF wiper travel is when the arm is opposite the cable entry point. The sensor arm should be approximately opposite the cable entry point when the helm is in the mid-ships position.
- (4) When the rudder is moved hard-over port or hard-over starboard, the RRF arm should travel through a minimum angle of 90° to ensure sufficient voltage swing. Measure the voltage difference between the blue (0V) and green (signal) wires from the RRF; there should be at least a 1V dc change from port to starboard.
- (5) After fitting and connection of the RRF test the full movement of the steering gear to ensure no fouling occurs between the ram drive, steering gear and RRF.
- (6) Check for backlash in the linkages. Excessive backlash will cause errors in the operation of the autopilot.

The example opposite shows a plan view of a typical system with a tiller arm and quadrant. When viewed in elevation, the ram drive arm and rudder reference unit drag-link must not be more than $\pm 9^\circ$ from horizontal. Ideally, everything should be horizontally aligned as this prevents excessive stress during operation.

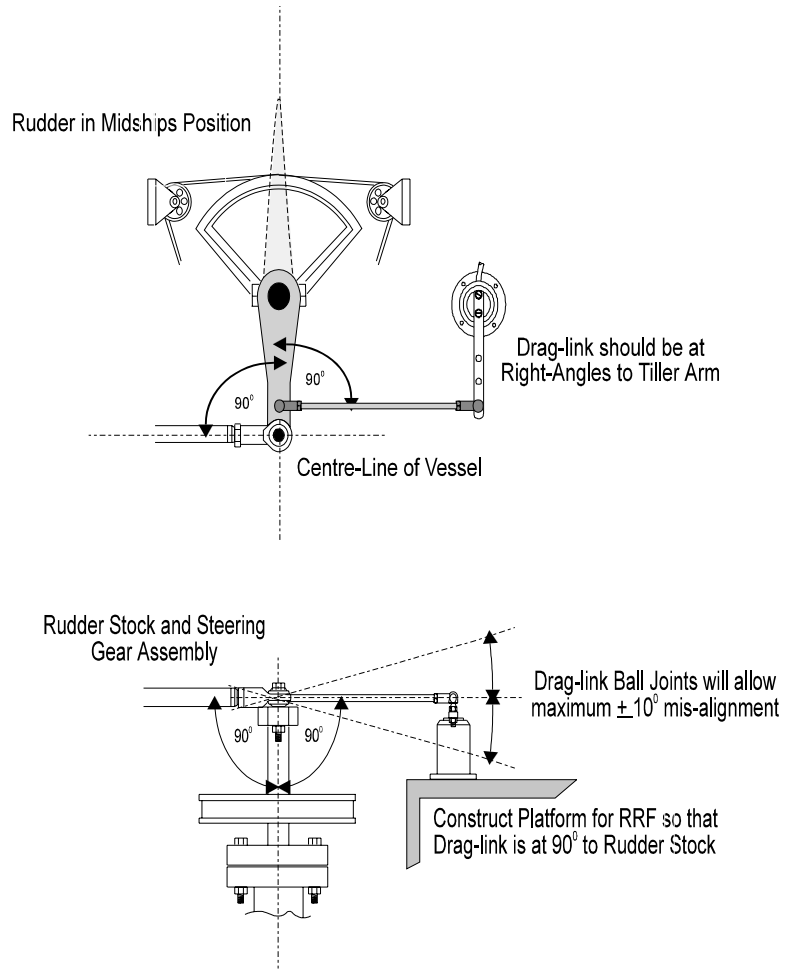

Fig 4.11 Plan View - Typical System with Tiller Arm and Quadrant

The RRF can be mounted in many different positions and orientations depending on the layout of the steering system.

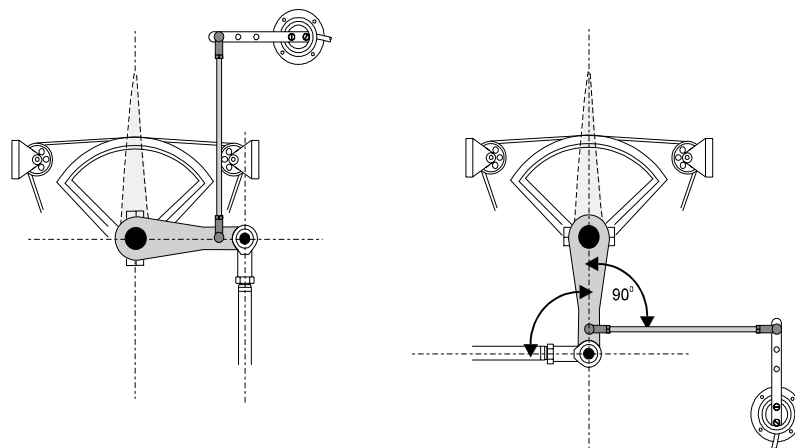

Fig 4.12 Steering System Orientation

If the maximum rudder angle is less than 90° then the position of the RRF or the drag-link must be adjusted so that the operating arm of the RRF swings through a minimum of 90° and the output voltage difference is greater than 1 volt from port to starboard lock. Measure the output of the RRF between the green and blue wires.

Note

If there is less than 1V dc difference, the autopilot will not commission.

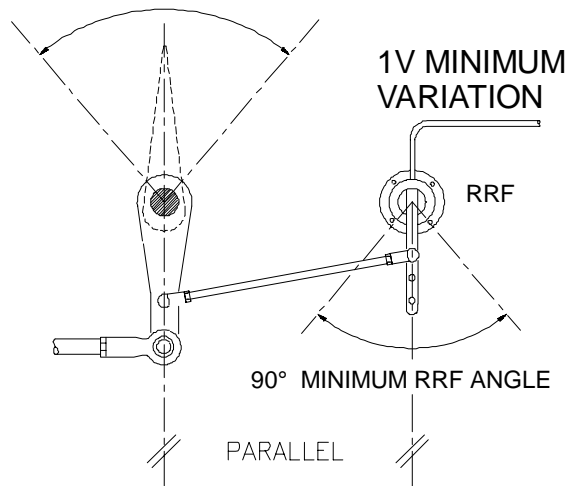

Fig 4.13 RRF Position

The rudder hard-over angle should only be limited by the rudder stops and not the RRF linkage. Check that when hard-over the RRF arm and drag-link, do not form a straight line. If this occurs, the steering system could become damaged or jammed endangering the boat and crew. Rectify this immediately by adjusting the position of the RRF.

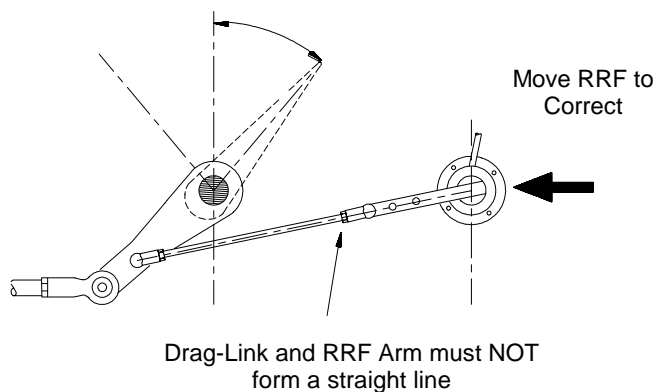

Fig 4.14 Drag-Link and RRF Position

4.4 LINEAR FEED BACK UNIT

4.4.1 Linear Feedback Unit

Where installation of the conventional rudder reference unit is difficult or physically impossible, a linear feedback unit (SEN-RUD-LFB) can be used. The linear feedback unit comprises of a tube approximately 23mm (7/8 inch) in diameter and 300mm (12 inch) long. This assembly is attached to the top of the B&G Blue Ram Types T1 or T2. Each end of the linear feedback unit has a small rose joint that is attached to corresponding pillars on the ram; the rose joints are retained using washers and spring clips.

Note: For electrical connection, refer to the table below.

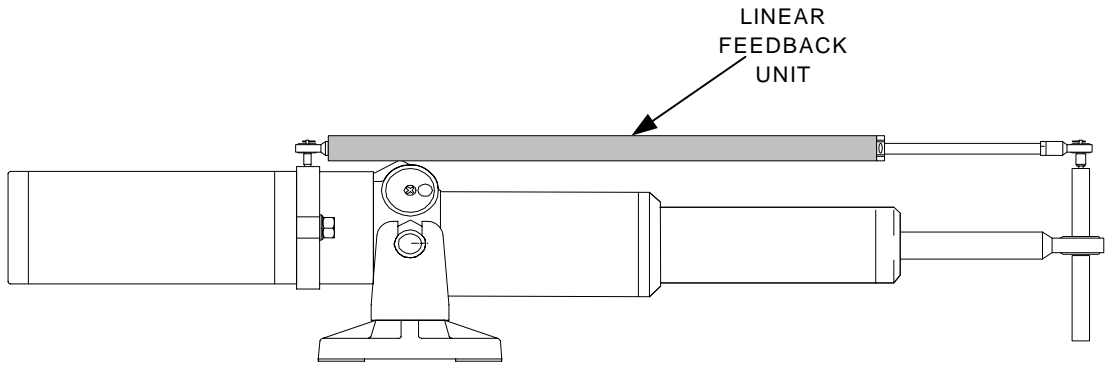

Autopilot Computer Colours	Function	Linear Feedback Colours
Red	+5V Supply	Red
Blue	0V Supply	Black
Green	Signal (Wiper)	Yellow

Fig 4.15 Linear Feedback Unit

4.5 RUDDER DRIVE UNIT

4.5.1 Description

A compact dc driven reversible hydraulic pump cylinder assembly for boats without hydraulic steering systems. Five sizes of ram are available giving a wide thrust range to suit all sizes and types of vessel.

Size 1 and Size 2 rams combine motor, pump and hydraulic cylinder as one unit referred to as an actuator. Size 3 and 4 rams are supplied split into a separate motor/pump unit, reservoir and hydraulic cylinder, connected by 1m/3ft hoses. Longer hoses are available, please contact your dealer. The units can also be mounted on a vertical bulkhead.

4.5.2 Sterndrive Unit Connections

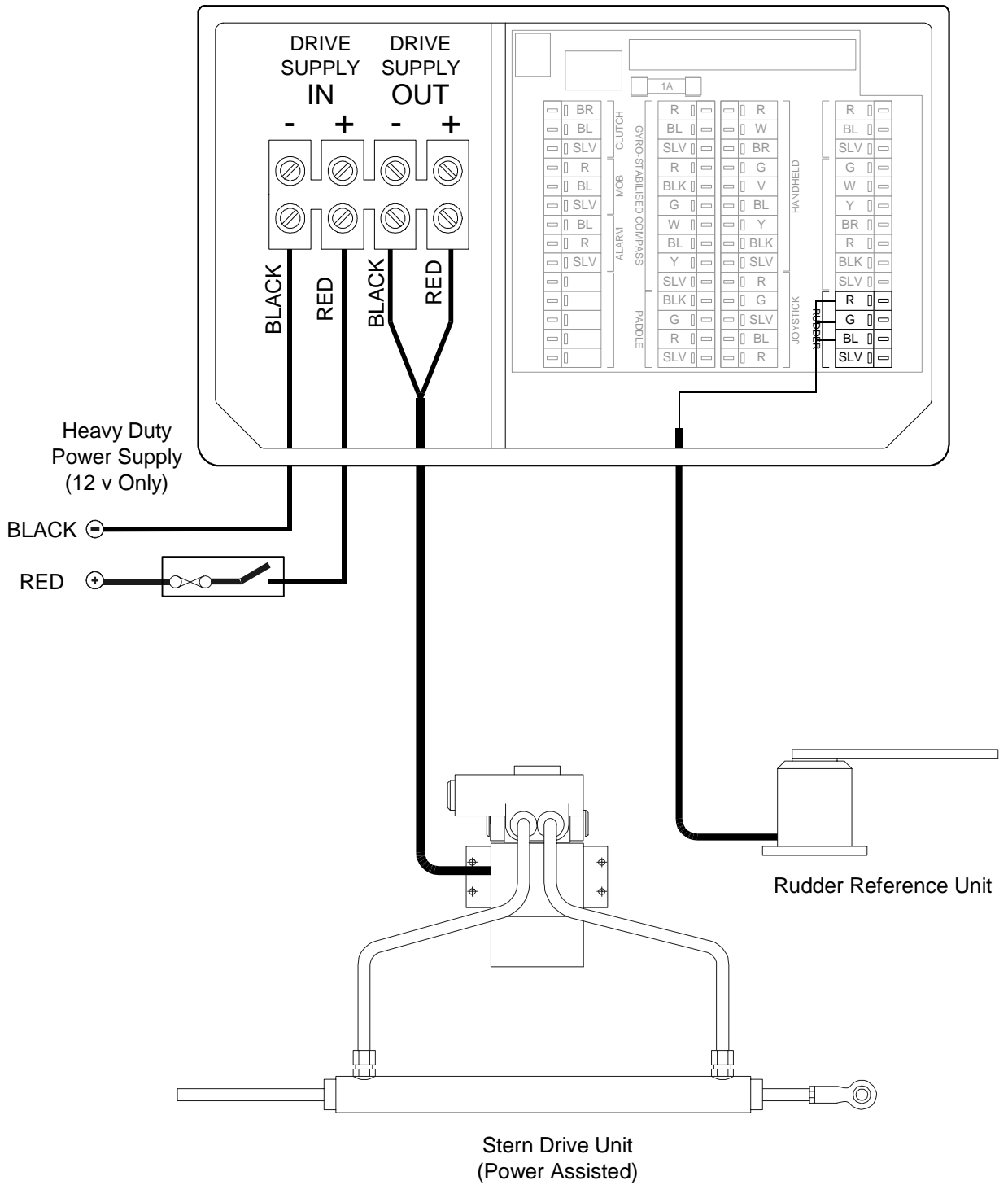

Fig 4.16 Sterndrive Unit Connections

4.5.3 Rotary Drive Connections

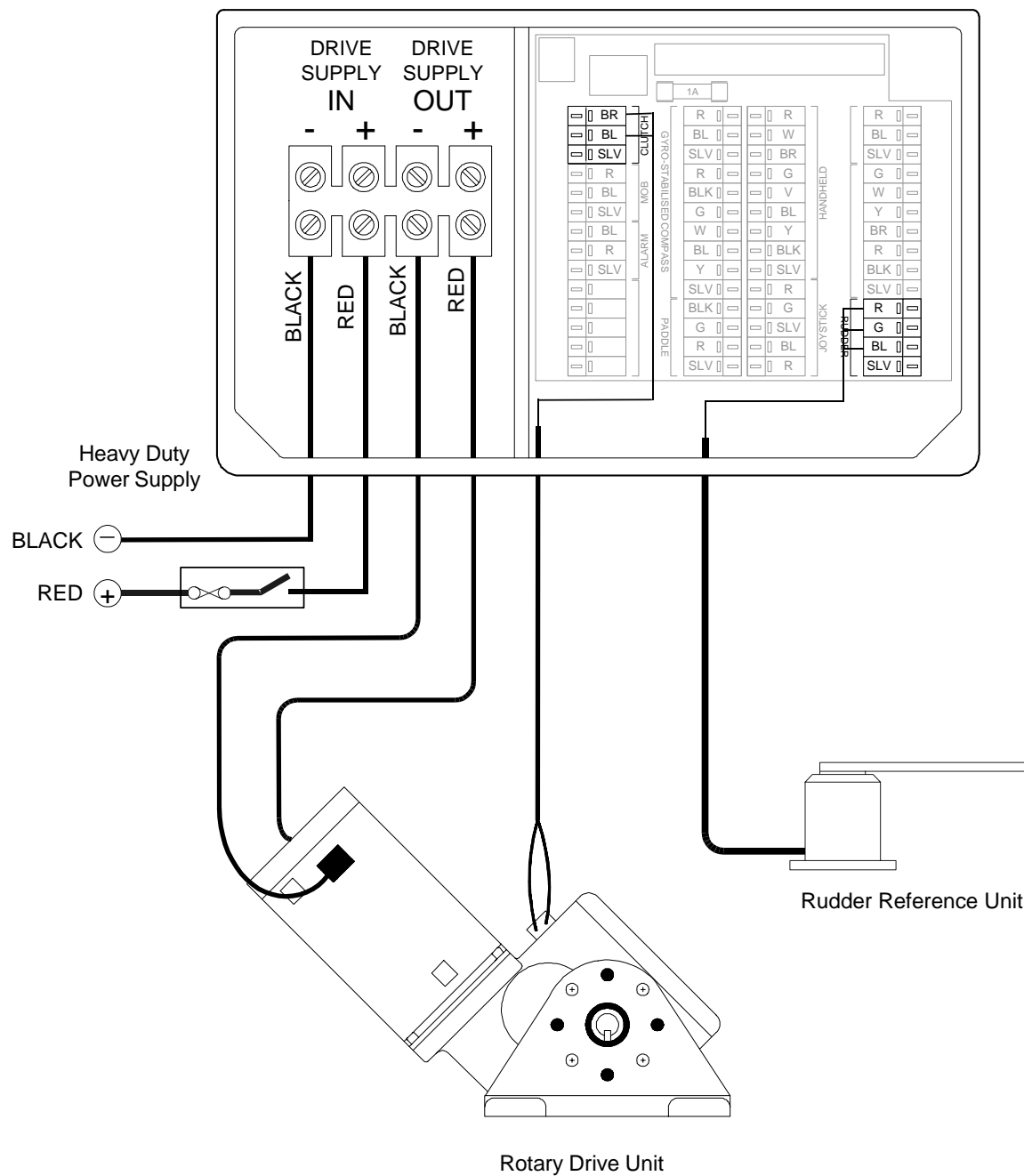

Fig 4.17 Rotary Drive Connections

4.5.4 Proportional Solenoid Connections

These are general wiring instructions only, showing the connection of the ACP Computer Unit outputs to drive proportional solenoid valves. The continuous drive pump motor will also require a heavy-duty supply; this is not shown on this diagram. The clutch output could be used to control the motor supply; the clutch output is only active while the Autopilot is moving the rudder.

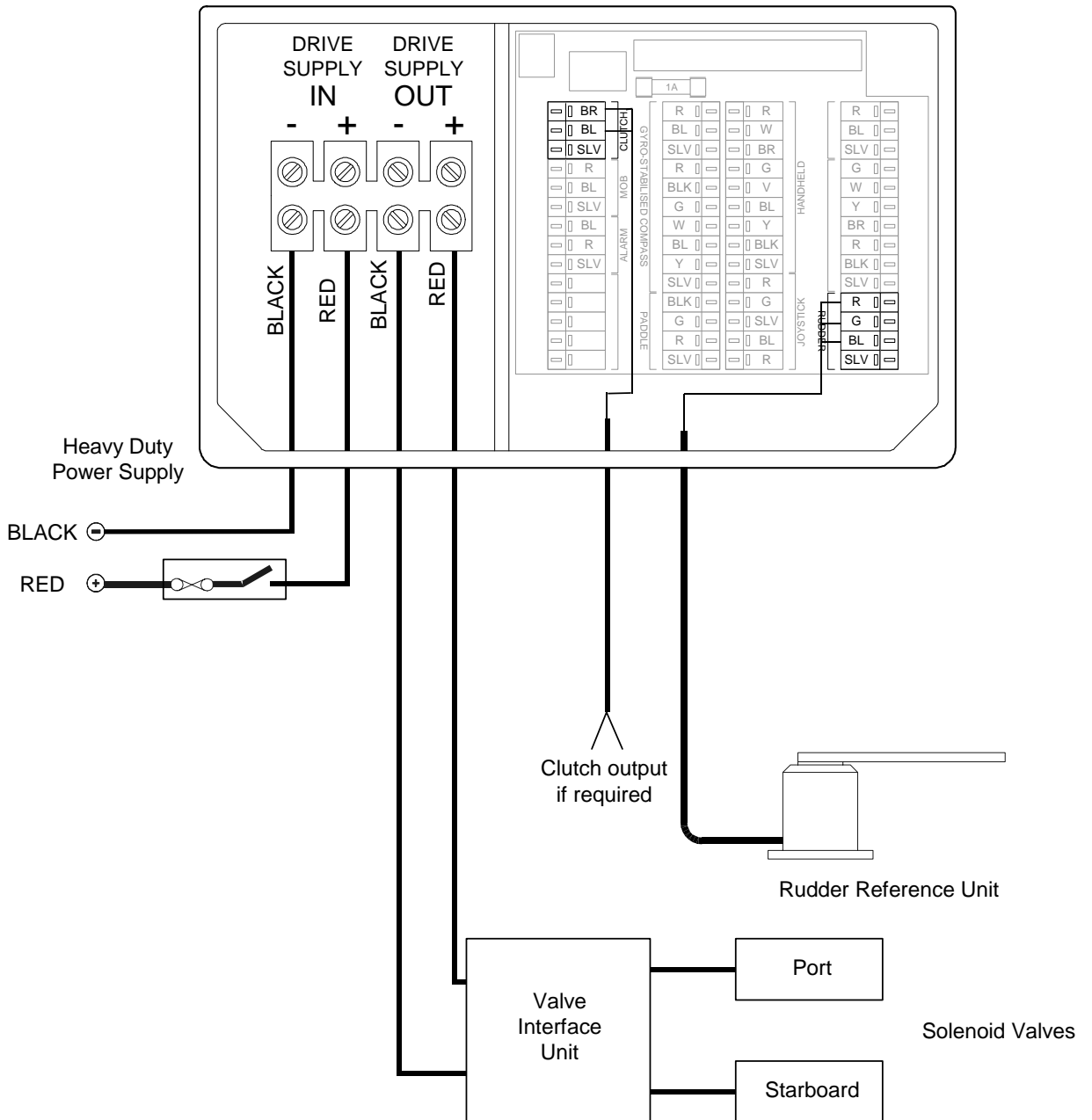

Fig 4.18 Proportional Solenoid Connections

4.6 USING A NON-B&G SPEED SENSOR

The speed sensor must have a speed signal output from a Hall-effect device giving positive pulses up to a maximum of 12V.

- (1) Locate the cable from the speed sensor to the instrument input.
- (2) Cut cable (if necessary) and insert a junction box (B&G Part No. 288-00-001). Connect like colour to like colour.
- (3) Use a length of 2-core screened cable (B&G Part No. 135-0B-098 9m/29.5ft) to connect the speed signal and ground of the paddle sensor to the speed input of the Autopilot computer unit.
- (4) Calibrate the speed input in accordance with the instructions given in Part 3 of this manual.

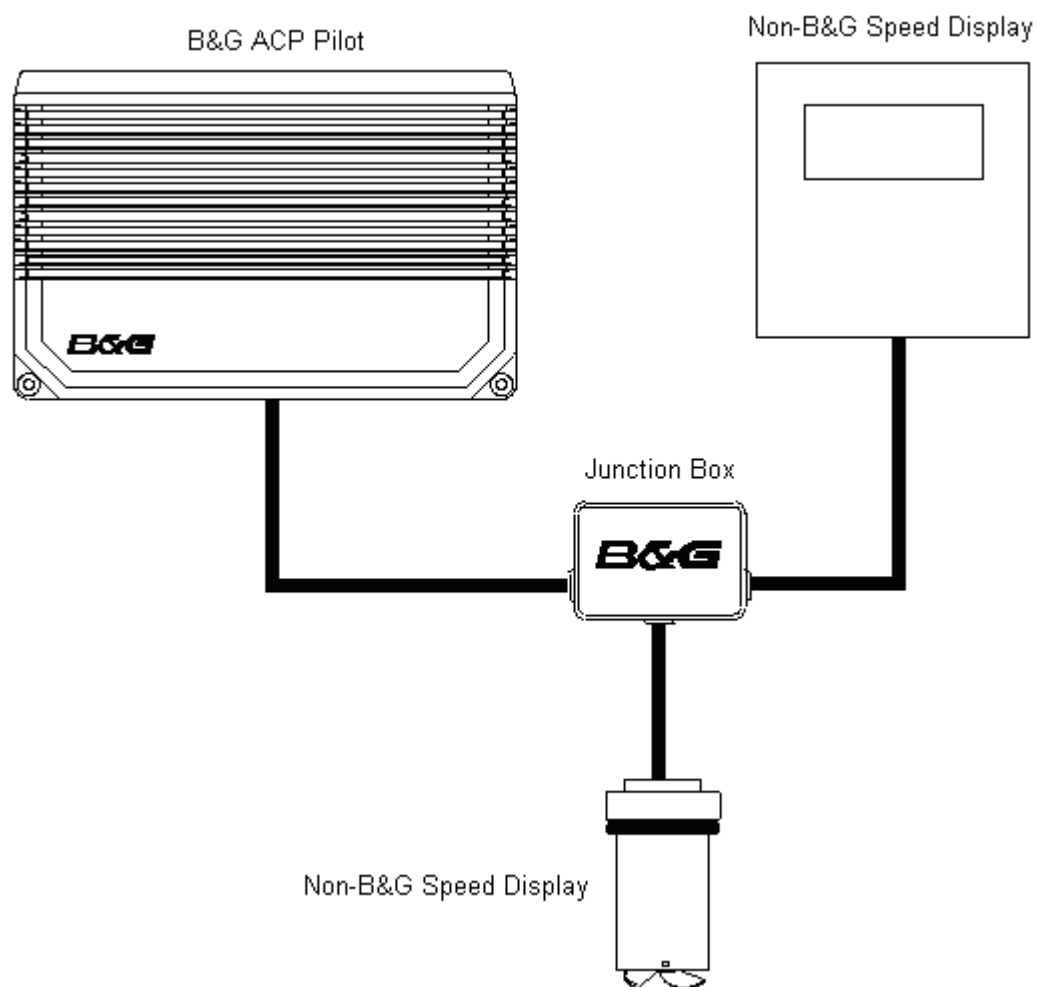

Fig 4.19 Non-B&G Paddle Connection

Autopilot Computer Unit Boatspeed Terminals	Function	Cable 135-0B-098
Green	Speed Signal Input	Red Wire
Red	Not Used	Not Used
Black	Ground	Blue Wire
Silver	Screen	Screen

Table 4.5 Non-B&G Paddle Connection

PART 5 - OPTIONS

CONTENTS

Para		Page
5.1	ADVANCED CONTROL PROCESSOR UNIT	5-2
5.2	RUDDER DRIVE DATA	5-3
5.2.1	Ram Drives	5-4
5.2.2	Type 0, 1 and 2 Ram Drives	5-6
5.2.3	Type 3 Ram Drive	5-8
5.2.4	Ram Drive Unit Installation	5-10
5.2.5	Mounting a Ram on a vertical Bulkhead	5-14
5.2.6	Splitting the Ram Drive Unit	5-14
5.2.7	Hydraulic Drive Pumps	5-15
5.2.8	Hydraulic Drive Pump Installation	5-17

ILLUSTRATIONS

Fig No		Page
5.1	Ram Drive Unit Dimensions - Type 1 and 2	5-6
5.2	Type 1 and 2 Rose Joint and Ram Bolt Detail	5-7
5.3	Ram Drive Unit Dimensions - Type 3	5-8
5.4	Type 3 Ram Bolt Detail	5-9
5.5	Typical Ram Drive Unit Layout	5-11
5.6	Ram Mounted Parallel to Vessel's Centre-Line	5-12
5.7	Vertical Bulkhead Installation	5-13
5.8	Type 1 and 2 Hydraulic Pump Dimensions	5-16
5.9	Type 3 Hydraulic Pump Dimensions	5-16
5.10	Single Station System Example	5-18
5.11	Dual Station System Example	5-18
5.12	Dual Station System with Bypass Example	5-19
5.12	Dual Station Pressurised System Example	5-19

TABLES

Table No		Page
5.1	Ram Drive Units	5-4
5.2	Ram Drive Technical Data	5-5
5.3	Hydraulic Drive Pump Data	5-15

PART 5 - OPTIONS

5.1 ADVANCED CONTROL PROCESSOR UNIT

The Advanced Control Processor (ACP) Unit contains all the electronics for the autopilot operation and control of the rudder drive options. It is designed to be mounted on a vertical flat, smooth surface. The unit has a hinged lid to provide easy access to the electrical connections within. There are two sizes of ACP unit available dependent on drive option requirements.

The ACP1 Computer Unit is required when the rudder drive options are:

RAM-T0-12V	Type 0, 12V Hydraulic Ram Drive
RAM-T1-12V	Type 1, 12V Hydraulic Ram Drive
PMP-T1-12V	Type 1, 12V Hydraulic Pump

The ACP2 Computer Unit is required when the rudder drive options are:

RAM-T2-12V	Type 2, 12V Hydraulic Ram Drive
RAM-T2-24V	Type 2, 24V Hydraulic Ram Drive
RAM-T3-24V	Type 3, 24V Hydraulic Ram Drive
RAM-T4-24V	Type 4, 24V Twin Ram Constant Running
PMP-T2-12V	Type 2, 12V Hydraulic Pump
PMP-T2-24V	Type 2, 24V Hydraulic Pump
PMP-T3-24V	Type 3, 24V Hydraulic Pump
PMP-T4-24V	Type 4, 24V Constant Running Pump*

* Special order

5.2 RUDDER DRIVE DATA

WARNING: Accurate performance of the yacht's steering system is crucial to the safety of you and your crew. B&G always recommend that an Authorised B&G Dealer performs the installation of autopilot drive units.

CAUTION: In line with B&G's policy of continuous product improvement, drive units are regularly updated. Installation data included with your drive unit will replace installation data contained in this manual. Before undertaking any shipwright work onboard the yacht, it is essential that the installation data in this manual be verified against your drive unit. If in doubt, consult your authorised B&G Dealer for technical assistance. B&G cannot accept liability for differences that may occur between the drive unit and this User Manual.

5.2.1 Ram Drives

A compact DC driven reversible hydraulic pump and cylinder assembly for boats without hydraulic steering systems. Five sizes of drive are available giving a wide thrust range to suit all sizes and types of vessel.

Type 0, 1 and 2 Rams combine the motor, pump and hydraulic cylinder into one unit referred to as an actuator. Type 3 and 4 rams are supplied split into a separate motor/pump unit, reservoir and hydraulic cylinder.

Ram Drive Type	RAM-T0-12V	RAM-T1-12V	RAM-T2-12V or 24V	RAM-T3-24V
Motor Supply	12V dc	12V dc	12 or 24V dc	24V dc
Solenoid Valve Supply	12V dc 1.25A (max)	12V dc 1.25A (max)	12 or 24V dc 1.25A (max)	24V dc 0.8A (max)
Peak Thrust	300 kg force (660 lbs force)	680 kg force (1496 lbs force)	680 kg force (1496 lbs force)	1062 kg force (2342 lbs force)
Peak Current	20A @ 12V	20A @ 12V	25A @ 12 or 24V	17A @ 24V
Maximum Stroke	203mm (8")	254mm (10")	254mm (10")	305mm (12")
Full Bore Annulus Area	776mm ² (1.203" ²) 662mm ² (1.027" ²)	1208mm ² (1.872" ²) 1005mm ² (1.558" ²)	1208mm ² (1.872" ²) 1005mm ² (1.558" ²)	1885mm ² (2.92" ²) 1570mm ² (2.434" ²)
Rod Diameter	12mm (0.472")	16mm (0.623")	16mm (0.623")	20mm (0.623")
Tiller Arm for 70° Rudder	178mm (7")	214mm (8.4")	214mm (8.4")	257mm (10.16")
Maximum Torque	545 Nm (4823.65 lb.ins)	1427 Nm (12574 lb.ins)	1427 Nm (12574 lb.ins)	2688 Nm (23780 lb.ins)
Weight	5.8 kg (12.7 lbs 6oz)	7 kg (15 lbs 6oz)	7 kg (15 lbs 6oz)	10.3 kg (22lbs 11oz)
Helm to Helm Time <i>Extend</i> <i>Retract</i>	10.1sec 9.9 sec (200kg force)	15.7 sec 13.4 sec (200kg force)	11.9 sec 10.2 sec (200kg force)	14.6 sec 12.6 sec (200kg force)

Table 5.1 Ram Drive Units

The following tables may be used to determine the correct tiller arm length for a typical steering system with a maximum rudder angle of 70°.

RAM T0 Hydraulic Linear Drive

RAM-T0-12V	Midstroke 429mm (16.9")
½ Max. Rudder Angle	Tiller Arm
35°	178mm (7.0")

RAM T1 and T2 Hydraulic Linear Drives

RAM-T1-12V RAM-T2-12V RAM-T2-24V	Midstroke 575mm (22.6")
½ Max. Rudder Angle	Tiller Arm
35°	214mm (8.4")

RAM T3 Split Hydraulic Linear Drive

RAM - T3-24V	Midstroke 755mm (29.7")
½ Max. Rudder Angle	Tiller Arm
35°	257mm (10.2")

Table 5.2 Ram Drive Technical Data

5.2.2 Type 1 and 2 Ram Drive Dimensions

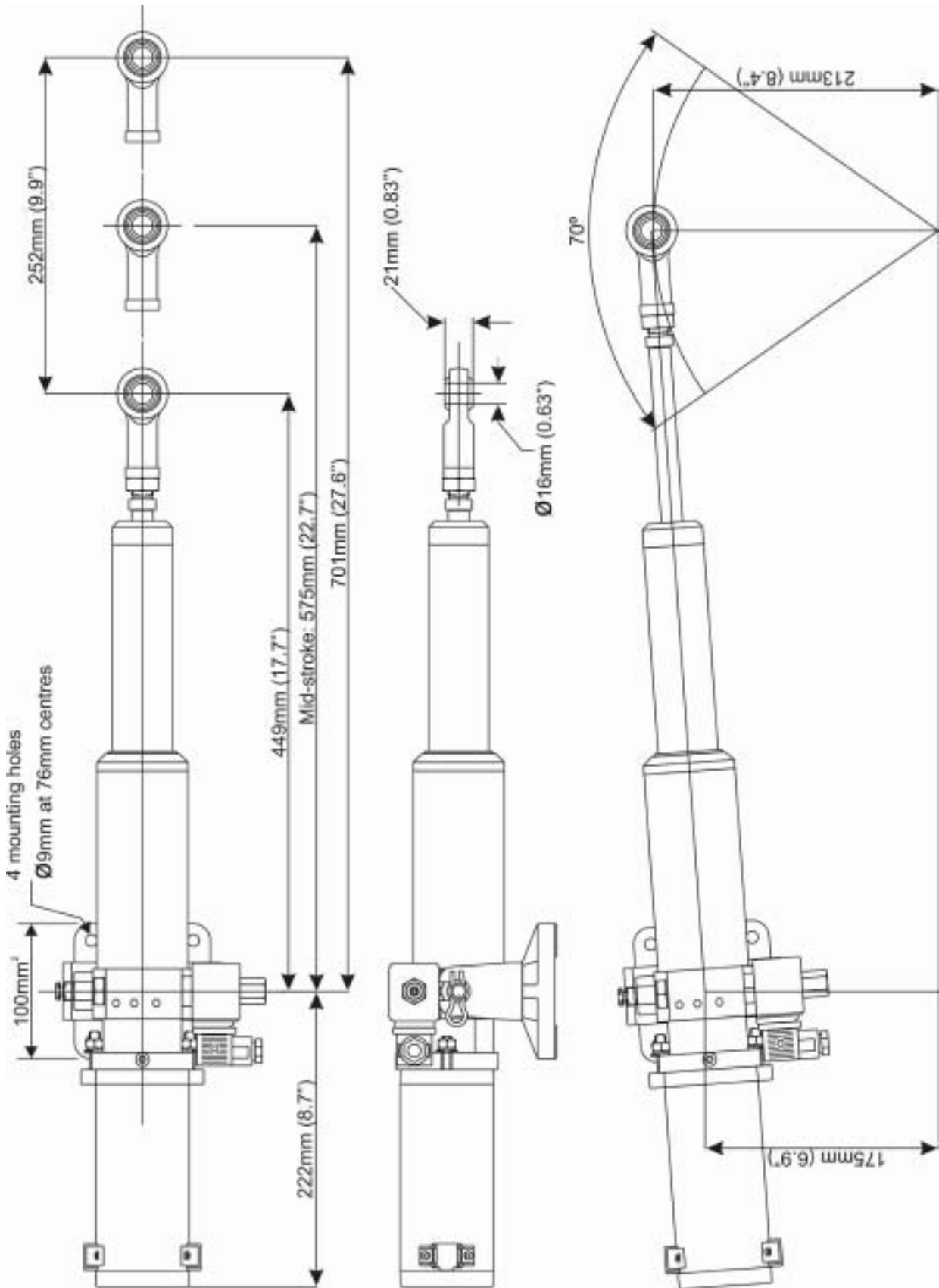

Fig 5.1 Type 1 and 2 Ram Drive Dimensions

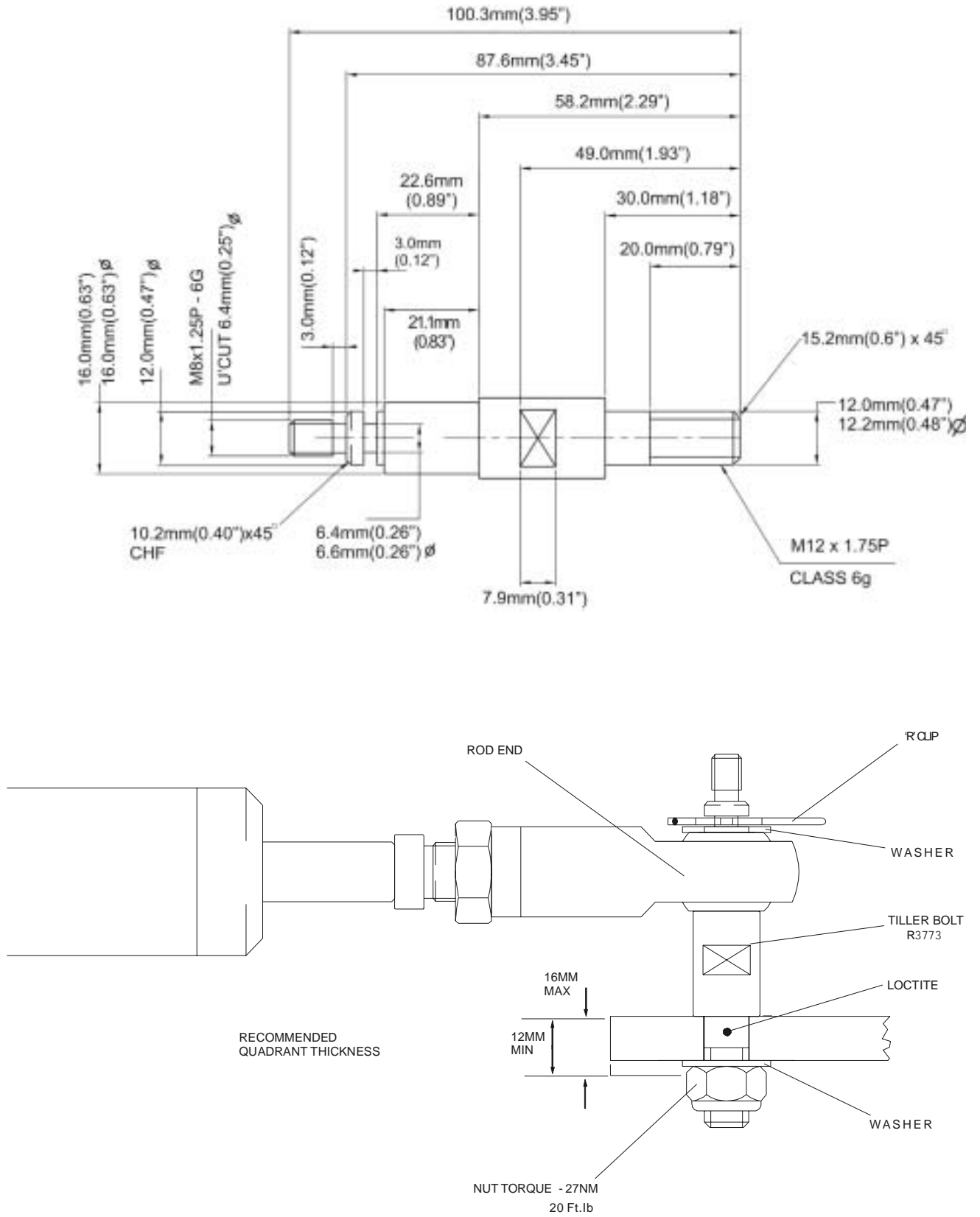

Fig 5.2 Type 1 and 2 Rose Joint and Ram Bolt Detail

5.2.3 Type 3 Ram Drive

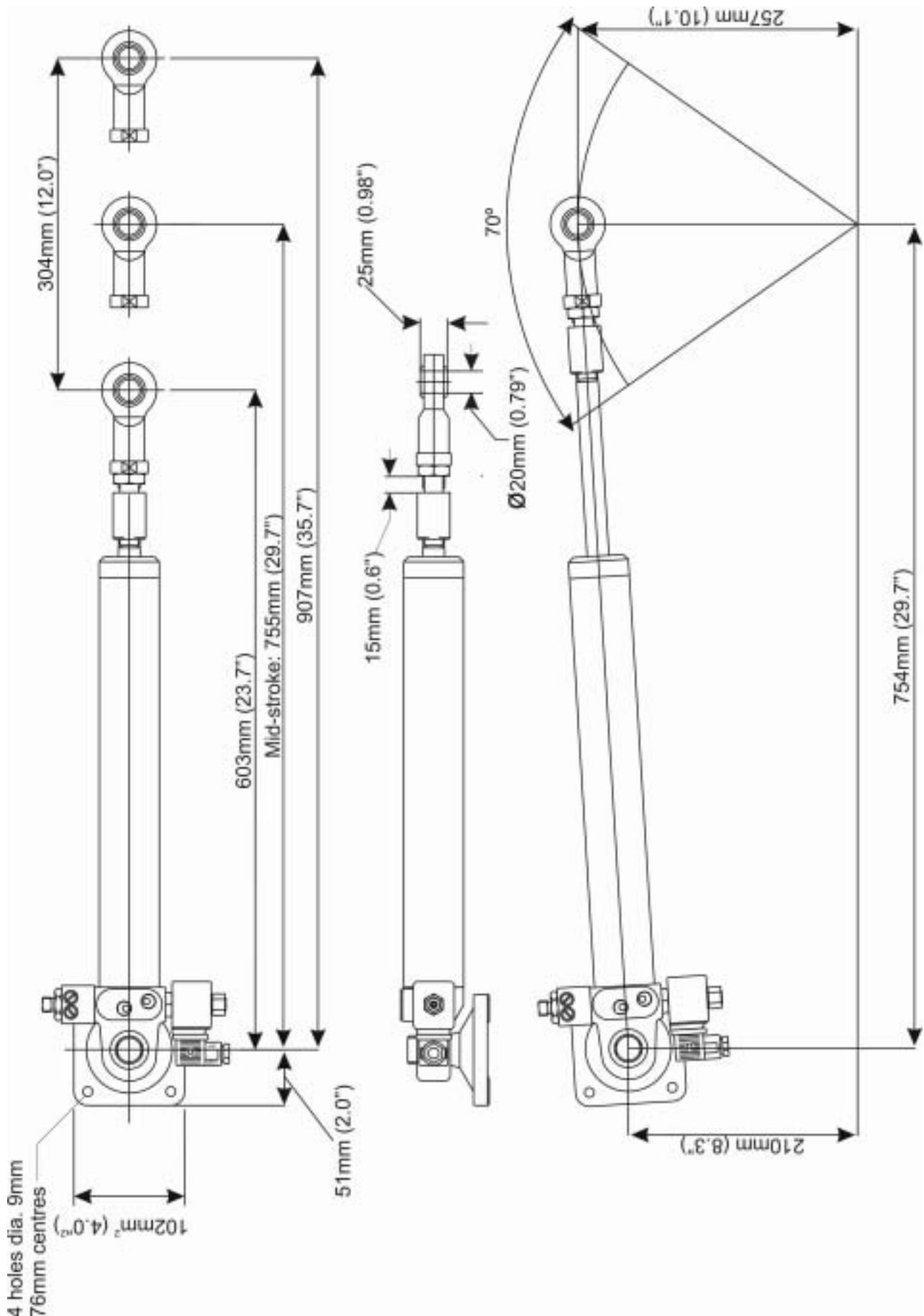

Fig 5.3 Type 3 Ram Drive Unit Dimensions

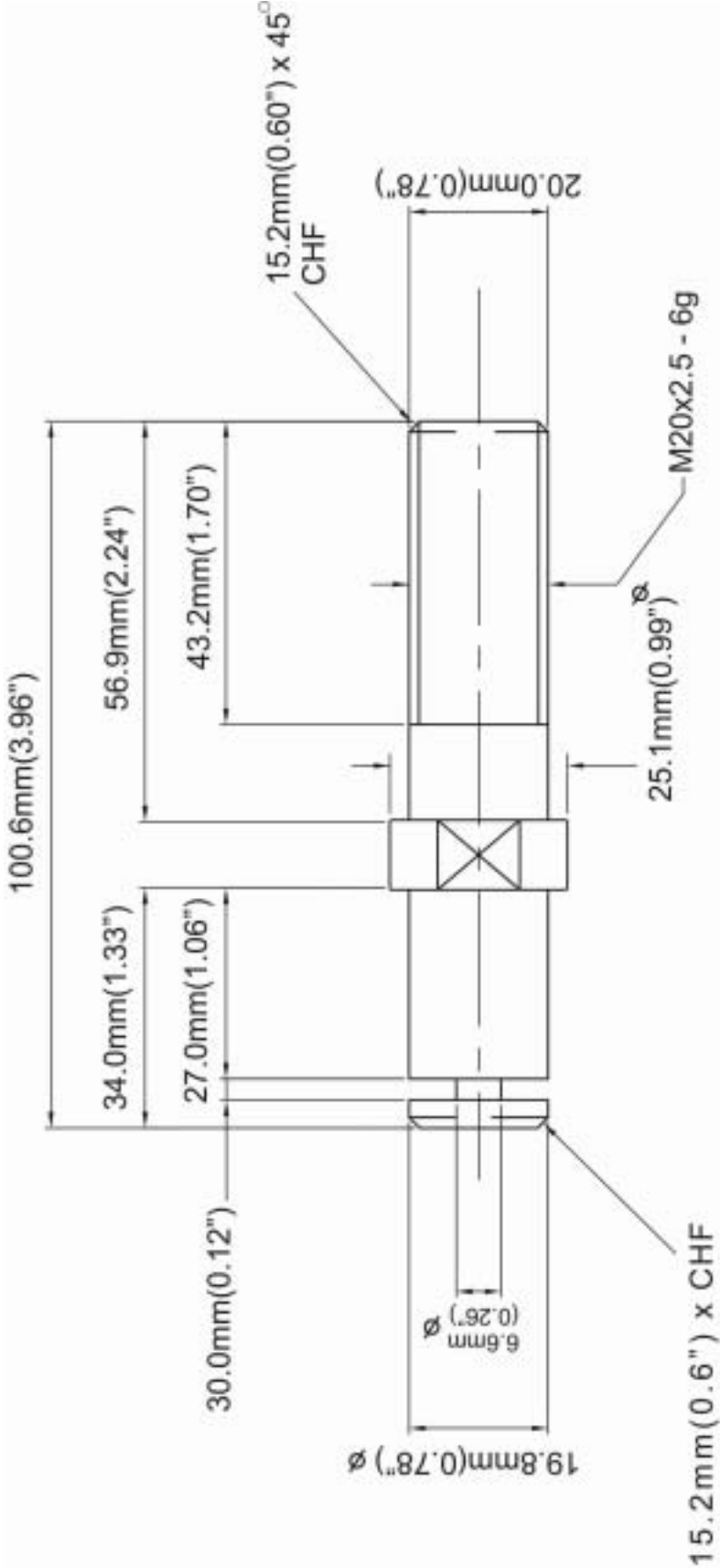

Fig 5.4 Type 3 Ram Bolt Detail

5.2.4 Ram Drive Unit Installation

General consideration must be given to the steering system and its geometry before starting the installation. Many factors must be contemplated for a practical solution. The information given here is for guidance only, although where a maximum or minimum value is given this must be adhered to.

It is essential that the unit is only installed in a fully functional steering system, with no backlash or stiffness when operating. Rectify any steering problems before installation of the ram drive unit or the autopilot will not function correctly.

KEY POINTS ON INSTALLATION

- ⚡ Check that the steering gear is in good condition. Rectify any steering defects before installation of the ram.
- ⚡ The ram drive unit must be secured onto a flat, rigid base; it may be necessary to construct a platform section for the mounting plate. For angled rudderstocks, an angled platform section will have to be constructed.
- ⚡ All setting up and aligning of the ram drive unit with the steering system should be carried out with the rudder in the amidships position and the ram arm at the centre point of its travel.
- ⚡ The angle between the ram arm and the tiller arm should be as shown in Figures 5.5 and 5.6.
- ⚡ The ram arm should ideally be at right-angles to the rudderstock. The ball-joint on the end of the ram arm will allow a **MAXIMUM** of $\pm 9^{\circ}$ of misalignment.

FOR TYPE 3 RESERVOIR INSTALLATION

Do not turn the black reservoir tap on or attempt to move the piston rod until all of the following are completed:

- ⚡ The base foot of the ram and pump have been bolted into position.
- ⚡ The reservoir has been fixed to a bulkhead above the ram and the pump.
- ⚡ The reservoir has been filled with the oil supplied.

The reservoir tap has been switched to the ON position allowing the oil to flow between the reservoir and the pipe.

Note

The tap ON position is in alignment with the pipe.

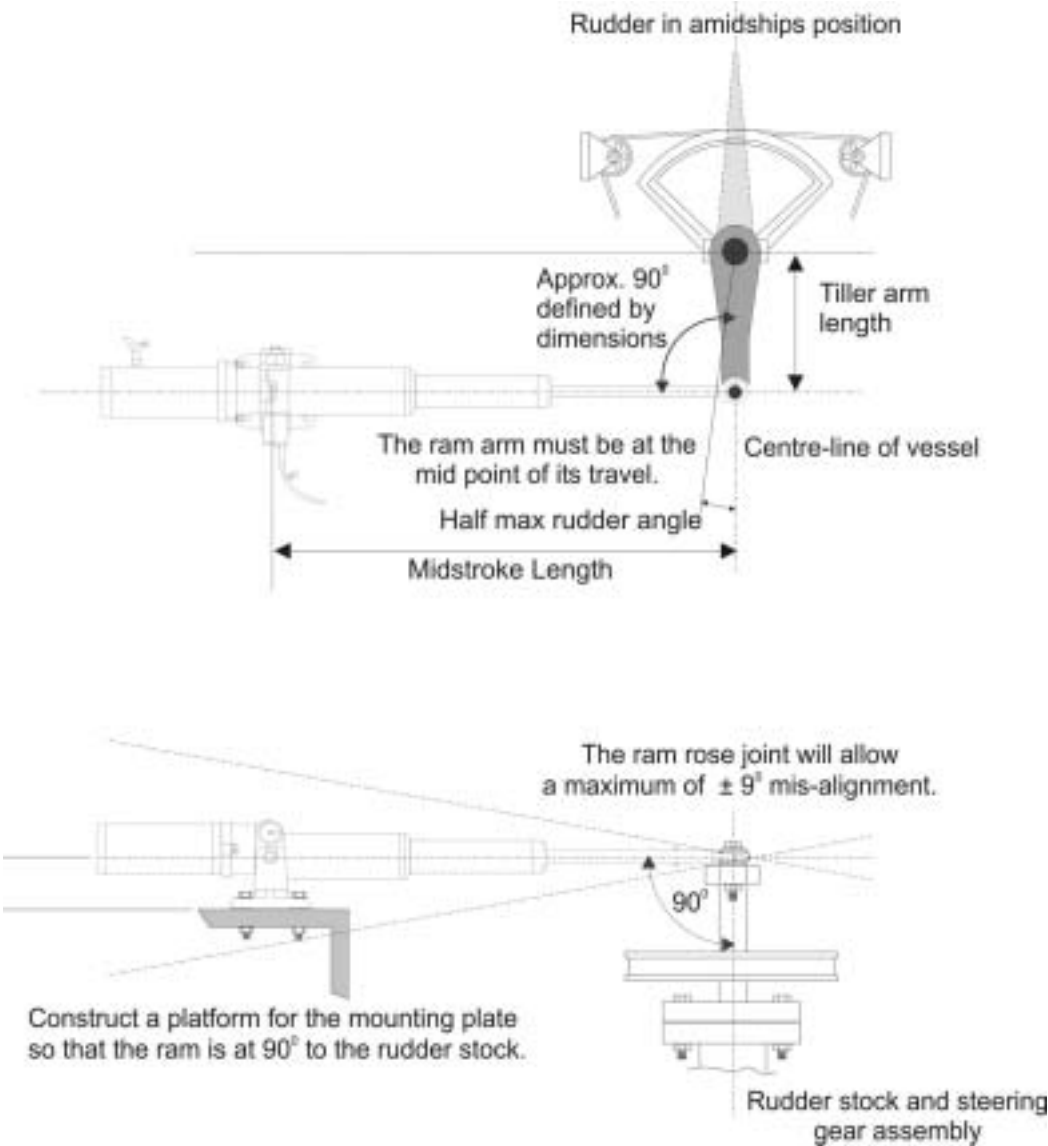

Fig 5.5 Typical Ram Drive Unit Layout

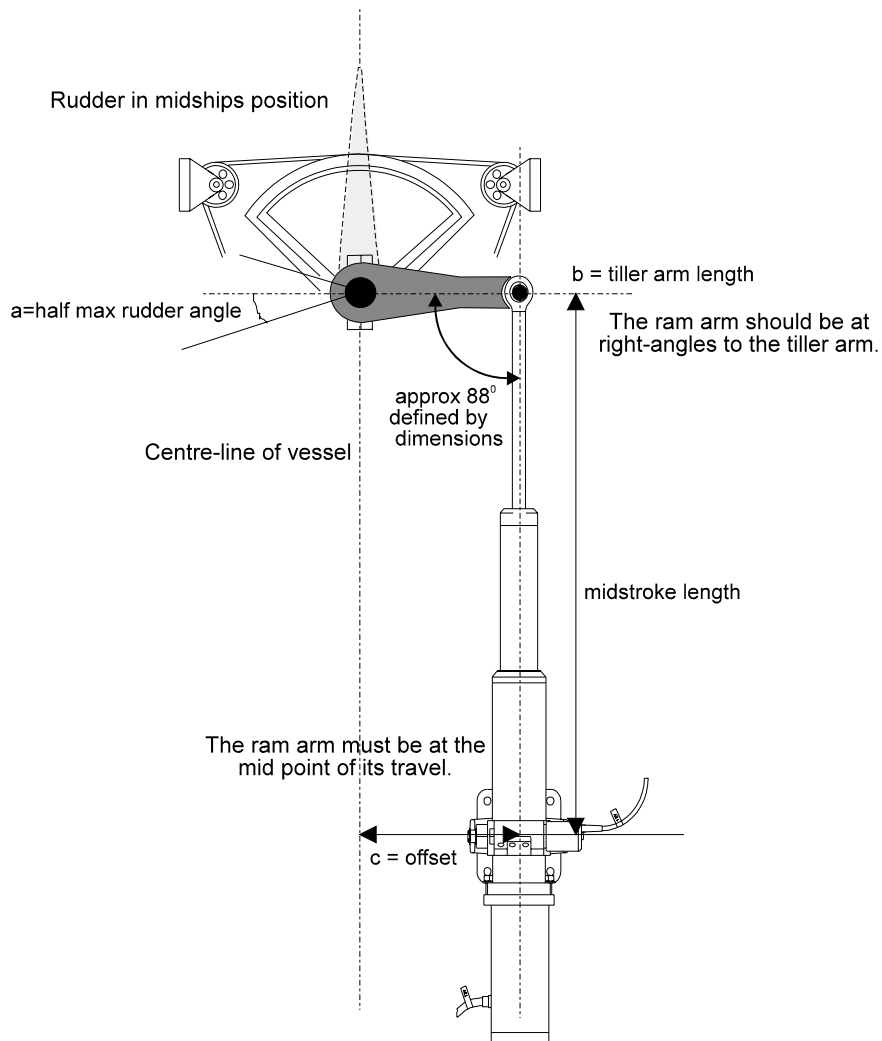

Fig 5.6 Ram Mounted Parallel to Vessel's Centre-line

KEY POINTS ON INSTALLATION

- ⚠ Ensure that the rudder angle is limited by the rudder stops and not the limit of travel of the ram arm. Failure to do this will damage the unit and invalidate the warranty.

- ⚠ Ensure that there is sufficient space at each end for the ram arm to extend fully.

- ⚠ Check for full movement and security of the steering gear before applying any power to the autopilot system.

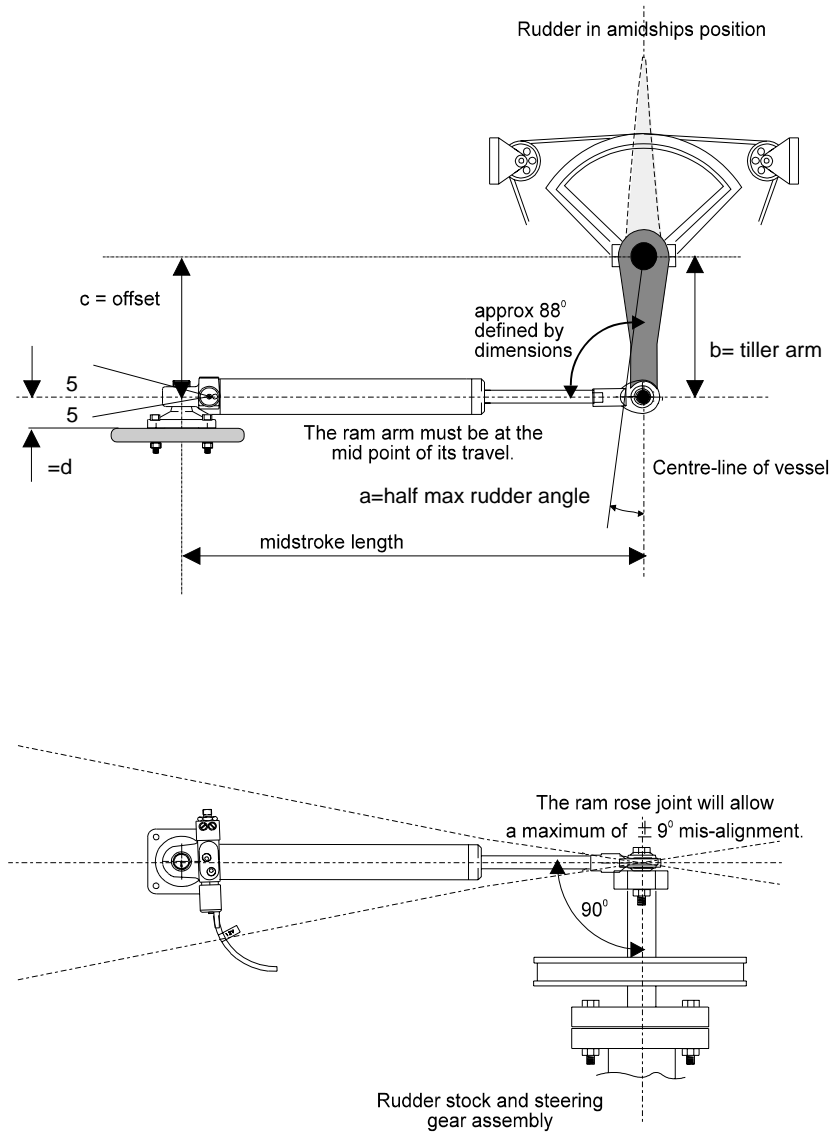

Fig 5.7 Vertical Bulkhead Installation

5.2.5 Mounting a Ram on a Vertical Bulkhead

Due to the restricted movement of the ram of $+14^{\circ}$, -10° for the Type 0, 1 and 2 and $\pm 5^{\circ}$ for the Type 3, it is important that the maximum rudder angle is carefully measured and the positioning of the ram, tiller arm length and offset are carefully followed as shown in Figure 5.7.

CAUTION: Failure to comply with these dimensions may cause premature failure of the ram and place excessive stress on the structure of the vessel.

The Type 0, 1 and 2 Rams may be mounted in any orientation, without the need to fit an external reservoir. The Type 3 Ram requires an external reservoir that must be mounted above the unit and care must be taken to ensure that the connecting pipes are not in any way kinked or turned through any tight bends.

5.2.6 Splitting the Ram Drive Unit

Important Note

When dealing with any hydraulic system great care must be taken to ensure that a high degree of cleanliness is observed and no dirt, moisture or foreign objects are allowed to enter the system. Only the recommended fluids must be used:

Use only Q8 DYNOLBEAR 10 or equivalent (10cSt at 40°C).

It is not possible to split linear actuators.

Type 1 and Type 2 units comprising separate ram/pumps, reservoirs and hydraulic cylinders connected by hoses, are available from your dealer. These are supplied with 1-metre hoses. Units with longer hoses are available from your dealer. These can be supplied with quick connect couplings and pre-filled hoses. Such units do not need to be bled.

Type 3 units are supplied as split units, connected by 1m (3ft) hoses. Units with longer hoses are available from your dealer. These can be supplied with quick connect couplings and pre-filled hoses. Such units do not need to be bled.

5.2.7 Hydraulic Drive Pumps

The Reversible Hydraulic Drive Pump has a small high speed pump driven by a 12V or 24V dc permanent magnet motor. The pump has autopilot check valves to prevent back driving and a pilot operated reservoir valve to enable the unit to drive balanced or unbalanced cylinders. The unit has Port and Starboard 1/4" BSP service ports and a 1/4" BSP reservoir port. Adapters for 1/4" BSP to NTP are available.

Hydraulic Pump Type	PMP-T1-12V	PMP-T2-12V	PMP-T3-24V
Pump Type	Reversible DC motor	Reversible DC motor	Reversible DC motor
Supply Voltage	12V DC	12V DC	24V DC
Typical Operating Current	5-17.5A	5-22.5A	6-17.5A
Maximum Pressure	1000 psi	1000 psi	1000 psi
Maximum Flow Rate	750 cc/min, 46 ins ³ /min	1420 cc/min, 87 in ³ /min	1980 cc/min, 121 in ³ /min
Cylinder Capacity	100 - 300 cc, 6.1 - 18.3 in ³	275 - 550 cc, 16.8 - 33.6 in ³	525 - 750 cc, 32 - 46 in ³
Weight	3 kg 6.6 lbs	3 kg 6.6 lbs	4 kg 8.8 lbs

Table 5.3 Hydraulic Drive Pump Data

KEY POINTS ON INSTALLATION

- ⚡ A position should be chosen convenient for the steering system hydraulic delivery lines.
- ⚡ The site should be rigid and flat to prevent excess vibration.
- ⚡ Shielded from the direct effects of the elements.
- ⚡ Minimise the lengths of the hydraulic lines from the pump to the cylinder and where possible the pump motor supply cables.

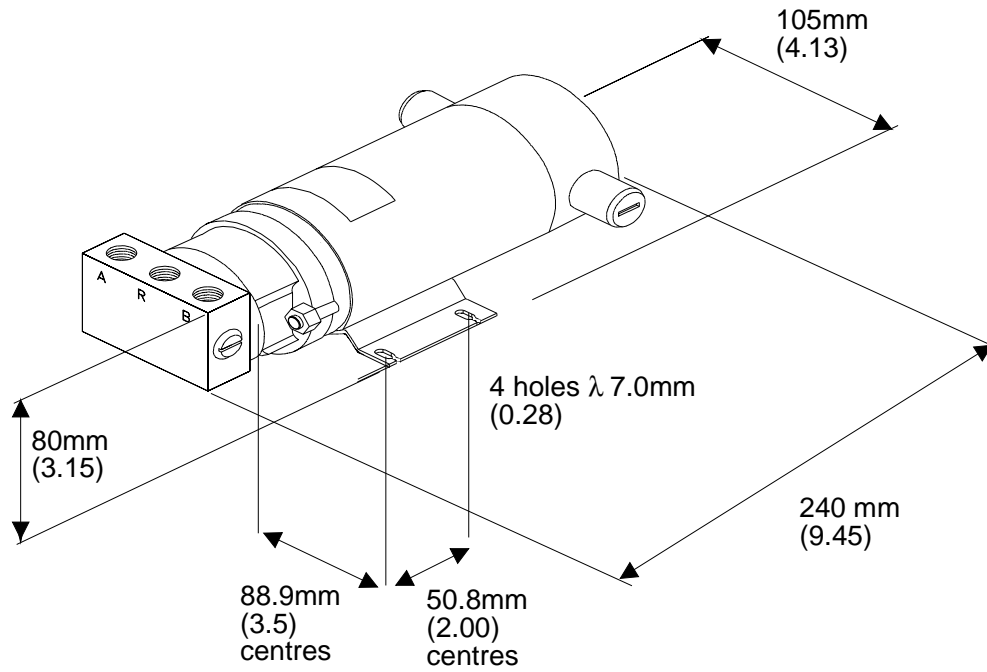

Fig 5.8 Type 1 and 2 Hydraulic Pump Dimensions

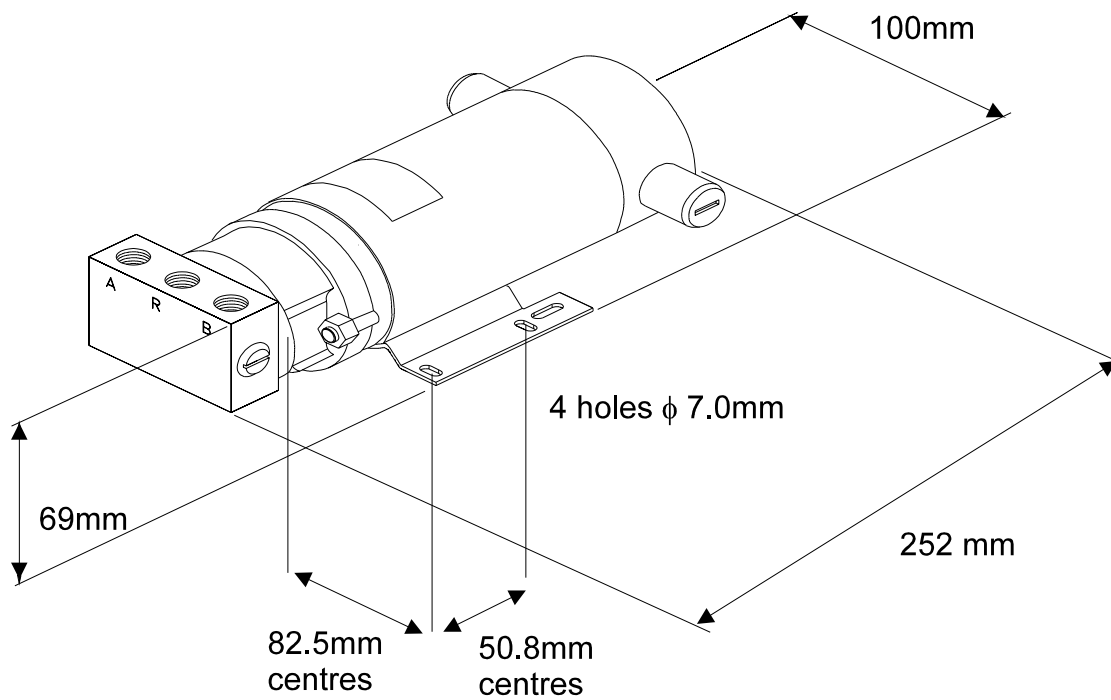

Fig 5.9 Type 3 Hydraulic Pump Dimensions

5.2.8 Hydraulic Drive Pump Installation

Important Note

When dealing with any hydraulic system great care must be taken to ensure that a high degree of cleanliness is observed and no dirt, moisture or foreign objects are allowed to enter the system. Only the recommended fluids must be used. Use Q8 DYNOBEAR or equivalent (10cSt at 40° C).

- (1) Drain the steering system from the lowest point, usually at a cylinder coupling.
- (2) Fit T-pieces into the port and starboard delivery lines, couple the lines to the appropriate service ports of the pump using flexible hydraulic hose.
- (3) Couple the reservoir port to the reservoir/balance line from the helm units. A low pressure, transparent plastic tube can be used. Ensure that this line rises gradually with no down turns.
- (4) Refill the steering system as recommended by the manufacturer, using clean hydraulic fluid.
- (5) Fill the cylinder by temporarily removing the cylinder couplings and hoses at each end, refit the hoses securely.
- (6) Starting at the highest helm unit, fill the helm reservoir.
- (7) Slowly turn the steering wheel two turns to port and then to starboard, checking the level of fluid in the helm unit reservoir at all times.
- (8) Next, turn the wheel fully in one direction until a slight pressure is felt, continuously monitor the reservoir level.
- (9) Repeat in the opposite direction and continue in this manner until topping up is no longer necessary.
- (10) When satisfied that the steering is fully bled manually, apply power to the pump unit.
- (11) Turning the wheel fully from lock to lock will cause the pump to self-purge.

- (12) Check the fluid level in the helm unit reservoir.
- (13) When the system appears to be fully functional, with the pump running and the helm hard over check for leaks.
- (14) Secure all hoses and cables to prevent damage.

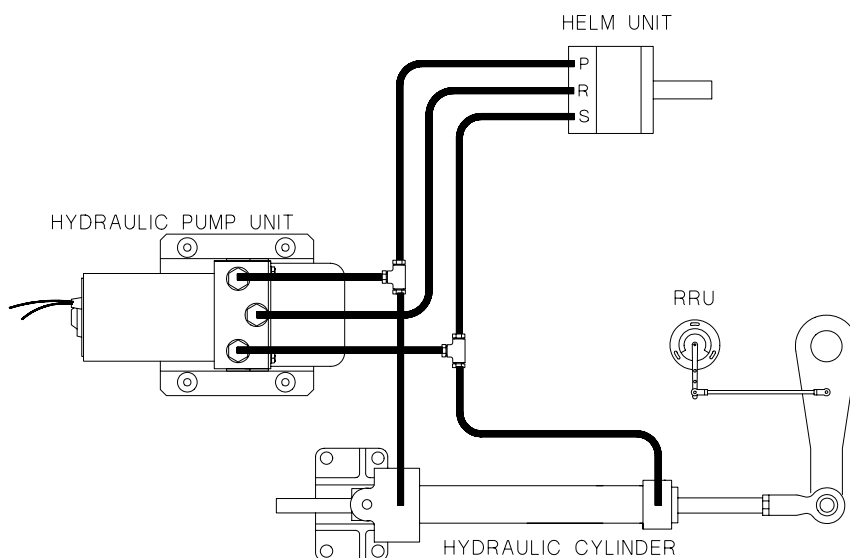

Fig 5.10 Single Station System Example

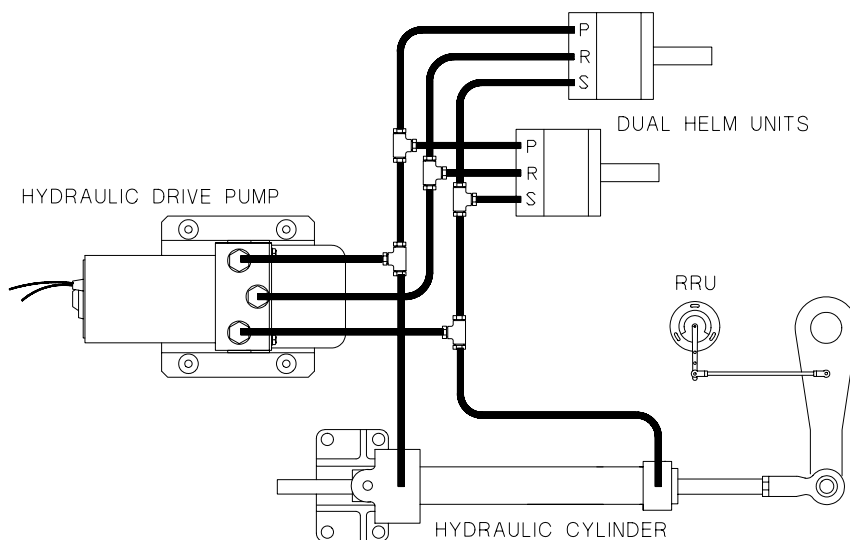

Fig 5.11 Dual Station System Example

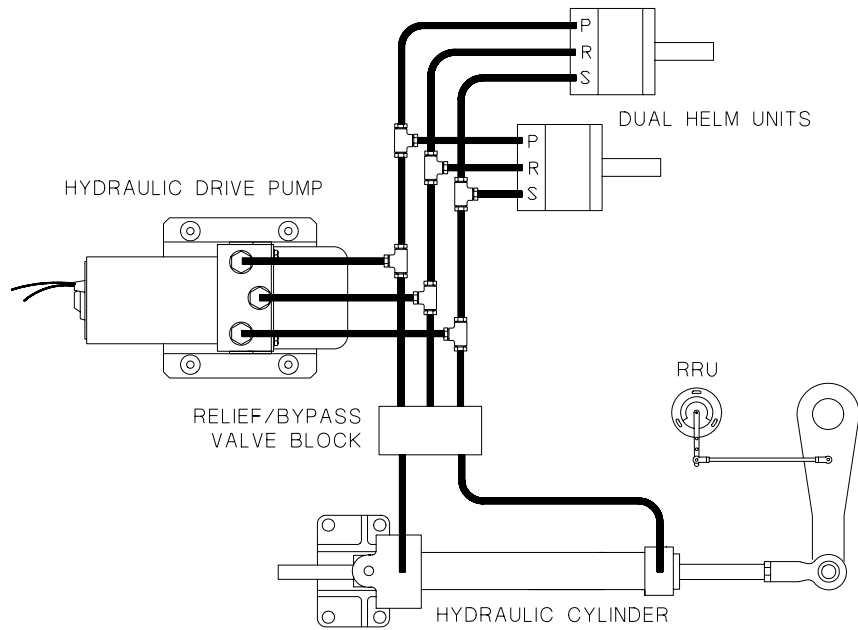

Fig 5.12 Dual Station System with Bypass Example

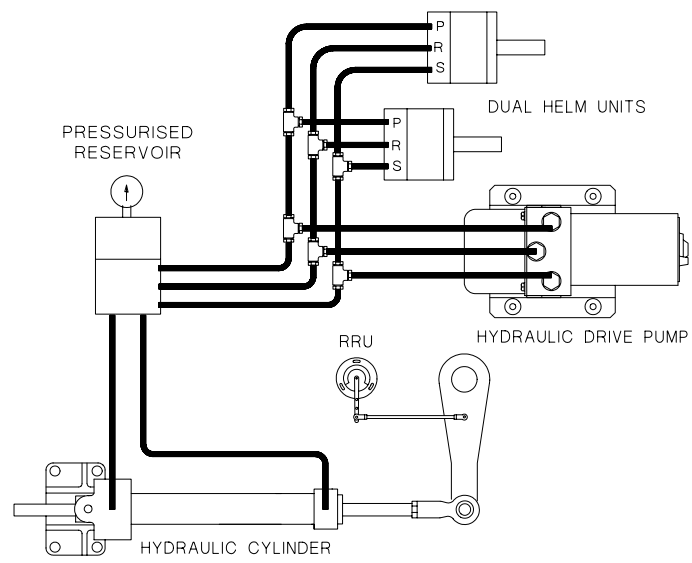

Fig 5.13 Dual Station Pressurised System Example

PART 6 - DIAGNOSTIC DATA

CONTENTS

Para		Page
6.1	DIAGNOSTIC DATA INTRODUCTION	6-3
6.1.1	Error Messages	6-3
6.2	FAULT DIAGNOSIS	6-6
6.2.1	Fault 100 - Uncommissioned	6-6
6.2.2	Fault 101 - Halcyon Gyro Stabilised Compass	6-7
6.2.3	Fault 102 - Rudder Reference	6-7
6.2.4	Fault 103 - Rudder Drive	6-8
6.2.5	Fault 104 - No Boat Speed	6-10
6.2.6	Fault 105 - External Compass	6-10
6.2.7	Fault 106 - No NMEA Data	6-10
6.2.8	Fault 108 - Bad NMEA Data	6-11
6.2.9	Fault 109 - No Wind Data	6-11
6.2.10	Fault 110 - No Optimum Wind	6-11
6.2.11	Fault 111 - Current Trip	6-12
6.2.12	Fault 112 - Network	6-12
6.2.13	Fault 113 – Memory Card Changed	6-13
6.2.14	Fault 114 – Autopilot Memory	6-13
6.2.15	Fault 115 – Drive Communications Failure	6-13
6.2.16	Autopilot Display Shows "No Pilot"	6-14
6.3	PILOT DOES NOT STEER IN A STRAIGHT LINE	6-16

ILLUSTRATIONS

Fig No		Page
6.1	Autopilot Display Fault Indication	6-3

TABLES

Table No		Page
6.1	Error Messages	6-3

Intentionally Left Blank

PART 6 - DIAGNOSTIC DATA

6.1 DIAGNOSTIC DATA INTRODUCTION

The Autopilot Computer is continually monitoring the autopilot and Hydra/Hercules System for correct operation. If an error is detected the Autopilot Display will show an error message. When an error occurs, the system audible alarm will sound. To silence the alarm press the key adjacent to the **FAULT** legend twice on any Autopilot Display.

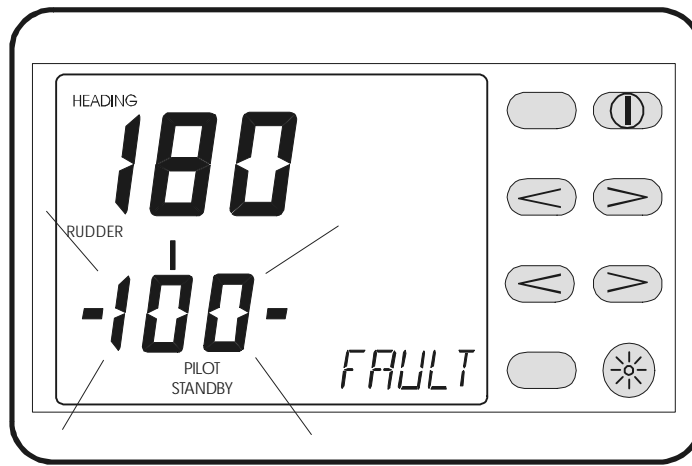

Fig 6.1 Autopilot Display Fault Indication

6.1.1 Error Messages

Fault	Cause	Fault Description
FAULT 100	Autopilot Uncommissioned	Rudder not commissioned or memory corrupted
FAULT 101	Halcyon Gyro Stabilised Compass	The signal from the compass is too large or too small
FAULT 102	Rudder Reference Unit Fault	The signal from the rudder reference unit is outside of the limits set during commissioning
FAULT 103	Rudder Drive	The autopilot attempted to move the rudder but did not sense any change in rudder position

Fault	Cause	Fault Description
FAULT 104	No Boat Speed	The boat is stationary or the speed sensor has stopped transmitting data
FAULT 105	External Compass	Heading data from Halcyon 2000 Compass or Gyro Sensor has stopped
FAULT 106	No NMEA Data	Navigational data from position fixer has stopped
FAULT 108	Bad NMEA Data	The value of XTE data being received has suddenly changed by more than 0.3 nautical miles
FAULT 109	No Wind Data	There is no valid wind data being received via the Instrument System network, or the wind speed is less than 1kt
FAULT 110	No Optimum Wind (Hercules Autopilot Only)	There is no optimum wind angle data being received via the Instrument System network
FAULT 111	Current Trip	The current limit circuit for the drive motor (25A ACP1 or 40A ACP2) or the clutch (2A) has tripped
FAULT 112	Network Fault	No regular messages being received by autopilot computer from autopilot display via Fastnet databus; i.e. either the display is not transmitting or the autopilot computer is not receiving
FAULT 113	Memory Card Changed	The memory card fitted is from another autopilot computer
FAULT 114	Autopilot Memory	Autopilot computer unable to access the memory card, most likely during a software upgrade
FAULT 115	Drive Communication Failure	Autopilot microprocessor unable to communicate with drive PCB

NO PILOT	Autopilot Display Unit	No regular messages being received by Autopilot Display from Autopilot Computer via Fastnet databus; i.e. either the display is not receiving or the autopilot computer is not transmitting
----------	------------------------	---

Table 6.1 Error Messages

6.2 FAULT DIAGNOSIS

6.2.1 Fault 100 - Uncommissioned

Fault Description

Rudder not commissioned or memory has been corrupted.

Remedy

(1) Has rudder ever been successfully commissioned?

Yes - go to 4.

No - go to 2.

(2) Set rudder end and mid positions, move helm, does rudder indicator work?

Yes - go to 4.

No - go to 3.

(3) Rudder indicator will not work until mid and end positions have been entered. The difference in the signal from the rudder reference unit at the Port end stop and the Starboard end stop must be at least 1.0 volt. Check rudder reference installation and then repeat 2.

(4) If rudder has previously been successfully commissioned then fault is due to memory corruption. This may be due to:

- Change of software version.
- Memory backup battery failure.
- Severe interference, e.g. lightning.

6.2.2 Fault 101 – Halcyon Gyro Stabilised Compass

Fault Description

The signal from the autopilot compass is too big or too small.

Remedy

- (1) Check for magnetic interference near compass position.
- (2) Check all wiring connections to the compass unit.
- (3) Suspect a fault with compass electronics. If the unit is replaced, the autopilot commissioning must be reset as follows:
 - Make a note of all commissioning values.
 - Without moving the helm, enter the Port and Starboard end stop positions.
 - Switch the 12V power off and then on.
 - Re-commission autopilot in the normal way using previously noted values.

6.2.3 Fault 102 - Rudder Reference

Fault Description

The signal from the rudder reference unit is outside the limits set during commissioning.

Remedy

- (1) Check installation of rudder reference unit for slack or loose fittings.
- (2) Check the signal from the rudder reference with a voltmeter at the autopilot computer. The voltage supply to the rudder reference should be 4.5 to 5.0 volts.

With someone moving the helm, the signal should change smoothly. If the signal is incorrect, suspect a faulty rudder reference unit. Note the difference between the signal voltages measured at the two end stops must be at least 1V dc.

(3) Set display (Hydra or Hercules) to show digital rudder angle in degrees. Move helm to Port and Starboard end stops; check that the indicated rudder angle is 40 degrees (+/-2). If not, check the rudder reference installation to determine and rectify the reason for the end stop position changing and then re-enter the set end stop commissioning values.

(4) Move helm slowly from end stop to end stop. Check that indicated rudder angle counts from 40 deg. one side to 40 deg. the other side without "missing" a count.

(5) If the fault is always at the same rudder angle, suspect a faulty rudder reference unit.

(6) If the fault is at different rudder angles suspect a fault in the wiring, the connections to the autopilot computer, or the autopilot computer electronics.

6.2.4 Fault 103 - Rudder Drive

Fault Description

The autopilot attempted to move the rudder, but did not sense any change in rudder position

or

When the autopilot attempted to move the rudder, it moved in the wrong direction.

Remedy

(1) Is the heavy-duty power supply circuit breaker for the autopilot drive switched on?

(2) Check installation, look for any slack or loose fixings in the drive system or the rudder reference as the helm is moved.

(3) Move the helm. Does the rudder indicator work, if not, check installation of rudder reference unit as detailed above.

(4) Select "Power Steer" mode. If drive system includes a clutch or solenoid valve, engage the pilot and check the operation of the clutch or solenoid valve. It should not be possible to move the helm with the autopilot engaged. If clutch fails to operate:

- Disconnect clutch from autopilot electronics and test operation when connected directly to power supply.
- Check correct Ampere rating is applied:

All pilots - selected voltage at up to 2 Amps.

(5) With autopilot engaged in "Power Steer" mode, use 10 deg. and 1 deg, Port and Starboard keys to move rudder. If the motor fails to run:

- Disconnect motor from autopilot electronics and test operation when connected directly to power supply.
- Check correct Ampere rating is applied:

ACP1 pilots - 12V or 24V up to 25 Amps.

ACP2 pilots - 12V or 24V at up to 40 Amps.

(6) If the fault occurs intermittently or under heavy loads, use power steer mode to move rudder while restricting movement by holding wheel. A fault occurring under these conditions could be due to:

- Excessive motor current.
- Too much slack or backlash in drive or fixing to tiller, possibly due to air in Hydraulic system.
- Software allows 3-speed control of drive motor for smoother rudder movement. The software increases the speed of drive motor if the drive motor stalls at slower speeds.

6.2.5 Fault 104 - No Boat Speed

Fault Description

The boat is stationary or the speed sensor is not working.

Remedy

- (1) If boat speed for pilot comes from instrument system, check speed shown on instrument system display.
- (2) If boat speed connected directly to pilot, check connections.
- (3) Check boat speed sensor for correct operation.
- (4) Change the speed setup from B.SPД sensor to S.O.G. or F.SPД if the paddle wheel sensor is inoperative.

6.2.6 Fault 105 - External Compass

Fault Description

Heading data from Halcyon 2000 Compass or Gyro Sensor has stopped.

Remedy

- (1) Check heading display on instrument system.
- (2) Check connections to Fastnet junction box or Gyro connections in autopilot computer.

6.2.7 Fault 106 - No NMEA Data

Fault Description

XTE data from position fixer via instrument system network has stopped.

Remedy

- (1) Check XTE display on instrument system.
- (2) Check connections to instrument system.
- (3) Check operation of Position Fixer. Has NMEA output been selected and enabled? Has autopilot output been enabled? Refer to the Position Fixer Manual.

6.2.8 Fault 108 - Bad NMEA Data

Fault Description

The value of XTE data being received has suddenly changed by more than 0.3 nautical miles.

Remedy

- (1) Check XTE on display for stability.
- (2) Check operation of Position Fixer, especially signal and noise levels. Refer to Position Fixer Operation Manual.

6.2.9 Fault 109 - No Wind Data

Fault Description

There is no valid wind data being received via the instrument system network, or the wind speed is less than 1 Knot.

Remedy

- (1) Check Wind display on instrument system.
- (2) Check connections to instrument system.

6.2.10 Fault 110 - No Optimum Wind (Hercules Autopilot Only)

Fault Description

There is no optimum wind angle data being received via the Hercules network.

Remedy

- (1) Check optimum wind angle display on instrument system.
- (2) Check operation of other Hercules 2000 Performance unit functions.

6.2.11 Fault 111 - Current Trip

Fault Description

The current limit circuit for the drive motor (25 Amps ACP1 or 40 Amps ACP2) or the clutch (2 Amps) has tripped.

Remedy

- (1) Check installation and wiring for short circuits.
- (2) Check current to clutch, maximum available 2 Amps.
- (3) Check current to drive motor, maximum available 25 Amps (ACP1) or 40 Amps (ACP2).

6.2.12 Fault 112 - Network

Fault Description

No regular messages being received by pilot control from pilot display via instrument system network, i.e. either the display is not transmitting or the autopilot computer is not receiving.

Remedy

- (1) If it is a new system that has never worked, check software of display:
 - Hydra autopilot display, version 4.2 or later.
- (2) If other displays show autopilot data, check installation and operation of autopilot display.
- (3) If autopilot responds to commands from other displays then autopilot computer is operating correctly.
- (4) Check installation of network cable.

6.2.13 Fault 113 – Memory Card Changed

Fault Description

The memory card fitted is from another pilot and the rudder end-stops are no longer valid. All other information will remain intact.

Remedy

(1) A pilot reset is required to reset the characteristics. Please consult your local authorised B&G Dealer for assistance.

6.2.14 Fault 114 – Autopilot Memory

Fault Description

(1) The memory card fitted is not for a pilot or the pilot software is not compatible with the contents of the card. To use the card a system reset will need to be done.

(2) No memory card or faulty memory card present.

Please consult your nearest authorised B&G Dealer for assistance.

Note

Fault 100 will indicate the presence of a valid pilot memory card but contains no commissioning information.

Remedy

(1) Replace pilot memory card.

6.2.15 Fault 115 – Drive Communications Failure

Fault Description

The pilot microprocessor is unable to communicate with the drive PCB.

Remedy

Check to ensure the high current supply is present or is not too low.

6.2.16 Autopilot Display Shows "No Pilot"

Fault Description

No regular messages being received by autopilot FFD from autopilot computer via instrument system network, i.e. either the display is not receiving or the autopilot computer is not transmitting.

Remedy

- (1) If other displays show autopilot data, check installation of autopilot display or suspect faulty autopilot display.
- (2) If no autopilot data on any display, check installation of autopilot computer or suspect faulty autopilot computer.
- (3) Check installation of network cable.

6.3 PILOT DOES NOT STEER IN A STRAIGHT LINE

Fault Description

The autopilot seems unable to steer straight, it continually overcorrects course errors; the wake has an "S" like appearance as the boat first steers several degrees off course to Port followed by several degrees off course to Starboard.

Remedy

- (1) Drive unit. Check for any slack or backlash in the drive system, see earlier section. For hydraulic steering, ensure that there is no air in the system.
- (2) Rudder reference. Check for any slack or backlash in the assembly and associated linkages, see earlier section.
- (3) Boat Speed. Check that the boat speed is operating correctly.
- (4) Settings. Read the commissioning manual carefully and check that the settings are appropriate for the type of boat.
- (5) Rudder gain. Make large course changes using the pilot, if the gain value is correct the rate of turn should be between 6 and 8 degrees per second. Adjust if necessary.
- (6) Boat lag. A boat lag value that is too small for the boat can cause instability, try increasing the value.

Intentionally Left Blank